

Alma Mater Studiorum - Università di Bologna

DOTTORATO DI RICERCA IN  
European Doctorate in Law and Economics (EDLE)

Ciclo XXV

Settore Concorsuale di afferenza: 13 A 1

Settore Scientifico disciplinare: SECS-P/01

TITOLO TESI

A threshold hypothesis of institutional change: collective action in the Italian Alps during the 13<sup>th</sup> - 19<sup>th</sup> centuries.

Presentata da: CLAUDIO TAGLIAPIETRA

Coordinatore Dottorato

Relatore

Prof. Luigi A. Franzoni

Prof. Marco Casari





## Abstract

This dissertation is about collective action issues in common property resources. Its focus is the “threshold hypothesis,” which posits the existence of a threshold in group size that drives the process of institutional change. This hypothesis is tested using a six-century dataset concerning the management of the commons by hundreds of communities in the Italian Alps. The analysis seeks to determine the group size threshold and the institutional changes that occur when groups cross this threshold. There are five main findings. First, the number of individuals in villages remained stable for six centuries, despite the population in the region tripling in the same period. Second, the longitudinal analysis of face-to-face assemblies and community size led to the empirical identification of a threshold size that triggered the transition from informal to more formal regimes to manage common property resources. Third, when groups increased in size, gradual organizational changes took place: large groups split into independent subgroups or structured interactions into multiple layers while maintaining a single formal organization. Fourth, resource heterogeneity seemed to have had no significant impact on various institutional characteristics. Fifth, social heterogeneity showed statistically significant impacts, especially on institutional complexity, consensus, and the relative importance of governance rules versus resource management rules. Overall, the empirical evidence from this research supports the “threshold hypothesis.” These findings shed light on the rationale of institutional change in common property regimes, and clarify the mechanisms of collective action in traditional societies. Further research may generalize these conclusions to other domains of collective action and to present-day applications.

## Samenvatting

Dit proefschrift bespreekt collectieve actie problemen inzake gemeenschappelijke bronnen. De focus is de “drempelhypothese”, die het bestaan van een drempel in groeps grootte veronderstelt die het proces van institutionele verandering stuurt. Deze hypothese is getest middels een dataset betreffende zes eeuwen beheer van gemeenschappelijke middelen bij honderden gemeenschappen in the Italiaanse Alpen. De analyse probeert de drempelwaarde van de groeps grootte te bepalen, alsmede de institutionele veranderingen die plaatsvinden wanneer groepen deze drempel overschrijden. Er zijn vijf hoofdbevindingen. Ten eerste, het aantal inwoners in de dorpen bleef stabiel gedurende zes eeuwen, ondanks dat de bevolking in deze regio in dezelfde periode verdrievoudigde. Ten tweede, de longitudinale analyse van face-to-face bijeenkomsten en de gemeenschapsgrootte hebben tot de empirische identificatie van een drempelwaarde geleid, die de overgang van informele naar formele regimes om gemeenschappelijke bronnen te regelen heeft veroorzaakt. Ten derde, wanneer de groepen groter werden, bleken er geleidelijke organisatieveranderingen plaats te vinden: grote groepen splitsen zich in onafhankelijke subgroepen of gestructureerde interacties in verschillende lagen, terwijl wel werd vastgehouden aan één formele organisatie. Ten vierde, heterogeniteit van de bronnen leek geen significante invloed op de verschillende institutionele karakteristieken te hebben. Ten vijfde, sociale heterogeniteit liet statistisch significante invloed zien, in het bijzonder op institutionele complexiteit, consensus, en het relatieve belang van governance regels versus regels ten behoeve van het management van de middelen. In het algemeen ondersteunt het empirische bewijs in dit onderzoek de “drempelhypothese”. Deze uitkomsten werpen licht op de rationale van institutionele verandering in gemeenschappelijke bronnen regimes en verklaren de mechanismes van collectieve actie in traditionele samenlevingen. Verder onderzoek zou deze conclusies kunnen uitbreiden naar andere terreinen van collectieve actie en hedendaagse toepassingen.

## Table of Contents

Abstract.....	iii
Samenvatting.....	iv
Table of Contents.....	v
List of Figures.....	xi
List of Tables.....	xiii
Acknowledgements.....	xvi
CHAPTER 1: INTRODUCTION.....	1
1.1 Introduction.....	1
1.2 Background of the Problem.....	2
1.2.1 Historical case studies.....	3
1.2.2 The Carte di Regola case study.....	3
1.3 The “threshold hypothesis”.....	4
1.3.1 The analysis.....	5
1.3.2 The framework.....	5
1.4 Statement of the Problem.....	7
1.5 Purpose of the Study.....	7
1.6 Significance of the Study.....	8
1.7 Methodology.....	9
1.7.1 Group size thresholds in institutions.....	10
1.7.2 Group fission and fusion in institutions.....	11
1.7.3 Effects of group heterogeneity and size on institutional design.....	12
1.8 Main results.....	13

1.9 Assumptions and Limitations .....	13
1.9.1 Assumptions.....	13
1.9.2 Limitations .....	17
1.10 Structure of the Remainder of the Dissertation.....	19
CHAPTER 2: THE <i>CARTE DI REGOLA</i> CASE STUDY .....	21
2.1 The Governance of Upland Commons .....	21
2.2. Village Communities in the Italian Alps, c. 1200–1800.....	27
2.2.1 The rise of the rural community in the Italian Alps.....	29
2.2.2 Village economics.....	31
2.2.3 Land tenure system .....	36
2.2.4 Regional-scale shocks.....	40
2.3 The <i>Carte Di Regola</i> .....	45
2.4 Conclusions.....	50
CHAPTER 3: DATA SOURCES AND DOCUMENTS.....	52
3.1 Introduction.....	52
3.2 Sources.....	54
3.2.1 Property rights.....	56
3.2.2 Content of documents .....	58
3.2.3 Organization of communities.....	61
3.2.4 Population, households, and assemblies .....	63
3.2.5. Land resources, climate, and topography .....	75
3.3. Datasets .....	79
3.3.1. The main dataset .....	80
3.3.2. Datasets used in Chapter 5.....	81
3.3.3. Datasets used in Chapter 6.....	84

3.3.4. Datasets used in Chapter 8.....	85
3.4. Conclusions.....	86
CHAPTER 4: THE THRESHOLD HYPOTHESIS .....	87
4.1. Introduction.....	87
4.2. The Commons.....	91
4.3. Common Property Rights .....	93
4.4. Type of Institutions and Organization .....	97
4.5. Group Size and the Type of Institutions .....	100
4.5.1. The cost of institutions.....	100
4.5.2. Does a threshold in group size exist?.....	105
4.6. Group Size and Cognitive Limits .....	106
4.6.1. The bounded rationality assumption.....	106
4.6.2. Bounded rationality and cognitive limits.....	107
4.6.3. Estimates of the threshold.....	111
4.7. Large Groups and Fission–Fusion Strategies .....	116
4.8. Conclusions.....	121
CHAPTER 5: GROUP SIZE THRESHOLDS IN INSTITUTIONS.....	123
5.1. Introduction.....	123
5.2. Methods.....	127
5.2.1. The resource specificity argument.....	128
5.2.2. The free-riding argument .....	130
5.2.3. The transaction costs argument.....	135
5.2.4. The heterogeneous preferences argument.....	138
5.2.5. The cognitive limits argument .....	142
5.3. Results and Discussion .....	143

5.3.1. Test of the resource specificity argument .....	144
5.3.2. Test of the free-riding argument .....	148
5.3.3. Test of the transaction costs argument.....	154
5.3.4. Test of the heterogeneous preferences argument .....	161
5.3.5. Test of the cognitive limits argument .....	164
5.4. Conclusions.....	179
CHAPTER 6: GROUP FISSION AND FUSION IN INSTITUTIONS .....	183
6.1. Introduction.....	183
6.2. Methods.....	189
6.2.1. Case selection and data categorization .....	189
6.2.2. Internal structure of multi-village organizations.....	191
6.2.3. Internal structure of communities .....	194
6.2.4. Group size estimates .....	196
6.2.5. Considering plenary versus partial assemblies .....	198
6.2.6. Fission, fusion, and institutional change.....	200
6.3. Results and Discussion .....	205
6.3.1. Empirical strategy .....	205
6.3.2. Internal structure of communities .....	205
6.3.3. Internal organization of multi-village organizations.....	205
6.3.4. Group size estimates .....	206
6.3.5. Village population distribution at last institutional change .....	208
6.3.6. Fission, fusion, and institutional change.....	209
6.3.7. Interpretation of the results: a simple model.....	212
6.4. Conclusions.....	226



CHAPTER 7: HETEROGENEITY AND INSTITUTIONAL DESIGN .....	229
7.1. Introduction.....	229
7.2. The Relevance of Heterogeneity.....	230
7.2.1. Definition .....	230
7.2.2. Heterogeneity in institutions .....	231
7.3. The Relevance of Institutional Design.....	234
7.3.1. Robust institutions .....	234
7.3.2. Institutional design.....	236
7.4. Conceptual Framework.....	239
7.5. Conclusions.....	240
CHAPTER 8: EFFECTS OF GROUP HETEROGENEITY AND SIZE.....	242
8.1. Introduction.....	242
8.1.1. Background.....	242
8.1.2. Research strategy .....	244
8.1.3. Research design .....	246
8.2. Methods.....	247
8.2.1. Social heterogeneity .....	247
8.2.2. Resource heterogeneity .....	260
8.2.3. Institutional design.....	267
8.2.4. Econometric model .....	275
8.3. Results and Discussion .....	280
8.3.1. Effects of social and resource heterogeneity .....	287
8.3.2. Effects of group size .....	291
8.4. Conclusions.....	296

CHAPTER 9: CONCLUSION .....	299
9.1. Introduction.....	299
9.2. Empirical Findings.....	302
9.2.1. Existence of a threshold group size in institutional change.....	302
9.2.2. Group fission and fusion as behavioral responses to the threshold .....	303
9.2.3. Social and resource heterogeneity in groups crossing the threshold .....	304
9.3. Theoretical Implications .....	306
9.4. Policy Implication.....	309
9.5. Limitations and Recommendations for Future Research.....	310
9.6. Conclusions.....	312
REFERENCES .....	313
APPENDICES .....	346
A. Definition of Terms.....	346
B. Initial Results.....	355
C. Figures.....	358
D. Tables .....	375
E. Case Histories.....	397
F. Codebook.....	427

## List of Figures

Figure 1.1. The “framework” .....	6
Figure 2.1. The Bishopric of Trent, 1648 .....	28
Figure 2.2. “Carta” of the community of Pinzolo, 1772 .....	358
Figure 2.3. “Banco de la Reson,” Valley of Fiemme, present day .....	358
Figure 2.4. Carte di Regola in Trentino, 1800 .....	359
Figure 3.1. Population estimates in Trentino (1200–1800) .....	360
Figure 3.2. Heterogeneity in natural resources .....	361
Figure 4.1. Distribution of group sizes in traditional societies .....	113
Figure 5.1. Aggregate surplus maximization on the commons .....	362
Figure 5.2. Group size estimates. Informal vs. formal institutions.....	362
Figure 5.3. When do larger communities adopt a charter? .....	363
Figure 5.4. Group size and institutional change (1350–1800).....	156
Figure 5.5. Active members in assemblies 1249–1801 .....	363
Figure 5.6. Participation. Unanimity vs. other quorums.....	364
Figure 5.7.1. Number of appropriators (log-scaled) 1249–1801 .....	165
Figure 5.7.2. Number of appropriators in 1249–1801 .....	364
Figure 5.8. Appropriators’ group size vs. population (1249–1800) .....	166
Figure 5.9. Simulation of Dunbar’s research setting using this study’s data.....	173
Figure 5.10. Upper bound group size for informal institutions .....	365
Figure 6.1. Internal structure of multi-village organizations .....	191
Figure 6.2. Internal organization of multi-village organizations .....	365
Figure 6.3. Appropriators’ group size: estimates, assembly data 1296–1796 .....	366
Figure 6.4. Village population distribution at last institutional change.....	366

Figure 6.5. Kernel densities: face-to-face interaction at last institutional change .....	367
Figure 6.6. Institutional changes through fission-fusion in 1200-1800 .....	204
Figure 6.7. Institutional change, structure, and group size .....	210
Figure 7.1. The framework: group size and heterogeneity .....	240
Figure 8.1. Research design .....	245
Figure 8.2. Surname fractionalization index .....	254
Figure 8.3. Number of villages within a community vs. assembly size .....	367
Figure 8.4. Surname Fractionalization: historical vs. simulated data .....	260
Figure 8.5. Transformation of the surname fractionalization index .....	368
Figure 8.6. Resource fractionalization index .....	369
Figure 8.7. Resource heterogeneity: classes of resources .....	370
Figure 8.8. Resource fractionalization: historical vs. simulated data .....	266
Figure 8.9. A summary of the results .....	291

### **Supplementary figures**

Figure S.1. Adoption of Carte Di Regola: a time profile .....	371
Figure S.2. Internal organization of multi-village organizations .....	371
Figure S.3. Assembly size: face-to-face meetings of group members (1296–1796) .....	372
Figure S.4. Village population distribution at first institutional change .....	372
Figure S.5. Empirical distributions. Last institutional change .....	373
Figure S.6. Kernel density. First institutional change .....	373
Figure S.7. Empirical distributions. First institutional change .....	374

## List of Tables

Table 1.1. Suggested reading paths.....	9
Table 3.1. Sources of data.....	55
Table 3.2. Population in Trentino (1200–1835).....	64
Table 3.3. Assembly roles 1245–1801.....	70
Table 3.4. Summary statistics: assemblies.....	375
Table 3.5. Number of appropriators on the commons (1245–1801).....	375
Table 3.6. Datasets.....	79
Table 4.1. Alternative governance regimes for upland commons .....	90
Table 4.2. Group size in modern hunter-gatherer societies .....	376
Table 5.1. Is group size resource-specific?.....	165
Table 5.2. Population estimates 1350–1800: summary statistics .....	377
Table 5.3. Median year of first charter adoption and group size classes .....	378
Table 5.4. Transaction costs: resources .....	379
Table 5.5. Transaction costs: remoteness from closest town.....	380
Table 5.6. Assembly quorums found in documents.....	161
Table 5.7. Number of appropriators (1245–1801).....	381
Table 6.1. Assembly levels .....	381
Table 6.2. Categories and samples.....	382
Table 6.3. Case selection: list of multi-villages.....	383
Table 6.4. Internal organization at last institutional change .....	384
Table 6.5. Internal structure at last institutional change: villages detail.....	384
Table 6.6. Internal structure at last institutional change: multi-villages.....	385
Table 6.7. Internal structure at last institutional change: multi-villages detail.....	385
Table 6.8. Appropriators’ group size: estimates on assembly data (1296–1796).....	386

Table 6.9. Institutional changes and group size in 1200–1800: detail.....	203
Table 6.10. Institutional change and fission–fusion: model predictions and observed behavior .....	219
Table 8.1. Surname fractionalization: summary statistics .....	251
Table 8.2. Summary statistics .....	256
Table 8.3. Surname fractionalization: summary statistics .....	386
Table 8.4. Surname fractionalization: cross-correlation table .....	386
Table 8.5. Resource fractionalization: summary statistics.....	261
Table 8.6. Resource fractionalization: summary statistics.....	387
Table 8.7. Resource fractionalization: cross-correlation table.....	387
Table 8.8. Consensus in assemblies: quorums.....	387
Table 8.9. Complexity of institutions: document length.....	282
Table 8.10. Complexity of institutions: number of assembly roles .....	283
Table 8.11. Mean number of articles per type .....	388
Table 8.12. Content of regulation .....	284
Table 8.13. Content of regulation (standardized coefficients).....	389
Table 8.14. Forward stability of the institution (uncensored observations) .....	285
Table 8.15. Quorums in assemblies .....	286
Table 8.16. Forward stability of the institution (uncensored observations) .....	390
Table B.1. Static model. Summary statistics – Year 1800.....	390
Table B.2. Institutional choice .....	391
Table B.3. Institutional choice: having a charter when pasture is prevalent .....	391
Table B.4. Institutional choice: having a charter when forest is prevalent.....	392
Table B.5. Event history model: risk of adopting a charter in 1200–1800.....	393

**Supplementary tables**

Table S.1. Population estimates 1350–1800 .....	394
Table S.2. Assembly size: face-to-face meetings of group members (1296–1796) .....	394
Table S.3. Plenary meetings, last institutional change: detail.....	395
Table S.4. Plenary meetings, first institutional change: detail.....	395
Table S.5. Summary statistics: institutions (full charters) .....	396
Table S.6. Summary statistics: institutions (modifications and other) .....	396

## Acknowledgements

This dissertation was made possible through the help, advice, and support of many individuals, to whom I am immensely grateful. Among them are friends and colleagues at the Rotterdam Institute of Law and Economics at Erasmus Universiteit Rotterdam, the Department of Economics at the University of Bologna, the Research Group on Social and Economic History at Utrecht University, and the Institute of Law and Economics at Hamburg University and others with whom I have interacted during the course of my EDLE thesis. I was fortunate to have two leading scholars of economic and legal science as my research supervisors, Professor Marco Casari and Professor Klaus Heine. I am indebted to Professor Casari, whose research on the commons in the Italian Alps contributed to the creation of the research question of this dissertation and who ceaselessly inspired me through his responsiveness, and deeply creative understanding of research in many areas of scholarship. Professor Heine took a personal interest in my work and made me feel that my work was important. His discerning command over a vast range of literature in economic and legal science was an invaluable resource for me.

Other scholars in each of the partner universities of the European Doctorate in Law and Economics have also had an influence on how the dissertation evolved. I offer my sincere thanks to Professor Luigi Alberto Franzoni, with whom, apart from our academic interest in law and economics, I share a passion for martial arts. In many conversations, he enlightened me on my limits and motivated me to take the dissertation challenge as an occasion for personal empowerment. I offer my sincere gratitude to Professor Michael Faure and Professor Patrick Leyens for their suggestions about the topic.

I am also grateful to Professor Vincent Buskens and Professor Tine de Moor, who played an important role in the development of the dissertation. Both followed the



development of this project from 2010 to completion and left deep impressions on my thought processes. Both provided precise, challenging comments. To Tine de Moor, I offer my particular gratitude for involving me in the Collective-Action.info initiative as well as in the international team project “Commons Rules,” which concerns the regulation of the commons in Europe 1100–1800. My wish is that our joint research collaboration will help to disseminate knowledge of the commons regulation in Europe in medieval and modern times.

During the winter term of 2011–2012, I was fortunate to benefit from interactions with scholars at Harvard Law School, where I met Professor Henry Smith, who provided valuable guidance on the legal aspects of my research. Professor Gary Libecap was an inspiring mentor for the future development of this work, and I am grateful for the hospitality he offered during my visit at the University of California Santa Barbara and for the informative discussions in which we engaged.

I am grateful to participants at the EDLE PhD seminars at the RILE, seminar participants at the Department of Social and Economic History at Utrecht University, and seminar participants at the class on complex networks at Northeastern University. I am also grateful to participants at the European Social Science History Conference (Glasgow, Scotland, 11 April 2012), the 2nd Thematic Conference of the IASC “Design and Dynamics of Institutions for Collective Action” in Utrecht, and the Italian Society of Law & Economics (SIDE-ISLE) 8th Annual Conference in Rome for their useful comments on parts of this dissertation.

This research would not have been possible without access to additional data from original sources and archives. I thank Katia Pizzini of the Diocesan Archive of Trento, Casimira Grandi, Mauro Nequirito, Cecilia Nubola, Emanuele Curzel, Cinzia Lorandini, Armando Tomasi, and the personnel of the public libraries of the Province of Trento for providing access and references to historical and archival sources and for assistance in

reading documents, which were at times difficult to translate from Latin or local dialect. I am particularly grateful to Marcello Liboni and the personnel of the Centro Studi Val di Sole in Terzolas, who provided access to many resources and library assistance for research. I would also like to thank Lisa Verniti, Antonio Trezza, Marianne Breijer, and Renè Van Weeren for their invaluable administrative assistance during the years of my doctoral studies.

I am also grateful for comments and feedback on the preliminary drafts of the work provided by Guido Alfani, Jean-Marie Baland, Albert-László Barabási, Torun Dewan, Pier Paolo Donati, Yadira Gonzales de Lara, Jonathan Klick, Jose-Miguel Lana Bersain, Valentino Larcinese, Dean Lueck, Maurizio Lisciandra, Chiara Monfardini, Trevor O'Grady, Sergio Pastorello, Nicola Persico, Paolo Pin, and Paolo Vanin.

I also thank, in no particular order, friends and colleagues at various institutions that contributed by providing input or feedback or by simply listening: Francisco Beltran Tapia, Miguel Laborda Peman, Fabio Bruè, Kleoniki Alexopolou, Mattia Nardotto, Tommaso Reggiani, Sarah Grace See, Viki Nellas, Francesco Manaresi, Pierluigi Murro, Delia Mocanu, Alfredo Guzman, and Bonnie Queen.

I do genuinely apologize to those whom I have failed to name above and request that they thoughtfully forgive the oversight and continue to maintain our interaction.

All errors are mine only.

## Chapter 1: Introduction

*Further progress in the study of transaction costs awaits the identification of the critical dimensions with respect to which transaction costs differ and an examination of the economizing properties of alternative institutional modes for organizing transactions.*—(Williamson, 1979)

### 1.1. Introduction

A group consists of a number of individuals who interact face-to-face, decide whether to cooperate, and collectively act toward the attainment of a common goal. An established body of literature has demonstrated that when a group grows in size, all else being equal, the likelihood of attaining a collective goal decreases (Hardin, 1968; Olson, 1965; Ostrom, 1990; Ostrom, Walker, & Gardner, 1992). Greed, or the incentive to “free ride” on others’ efforts by maximizing one’s benefit at the expense of others’, leads to a lack of coordination of group action and, thus, to the failure of collective action (Olson, 1965).

A similar hypothesis has been forwarded to explain why common-pool resources are likely to be depleted. Common-pool resources include, *inter alia*, irrigation systems, fisheries, pastures, forests, or water basins. These are distinguished from pure public goods because of the way they can be appropriated. Their size or natural characteristics can stop potential users from easily attaining benefits from their use. Individual incentives to extract the maximum benefit from a given resource and to minimize the share of the social cost of extraction lead to problems of congestion and overuse of the resource. These problems are peculiar of collective action situations (Olson, 1965) and may result in the depletion of the resource.

This situation is known in economics as the “tragedy of the commons” (Gordon, 1954; Hardin, 1968). Under an open access regime, there are no property rights over a common-pool resource: there is no definition of a group of users/owners, and there is no right for a user/owner to preclude the use by any other party. Since benefit streams from the resource are available to anyone, the resource is gradually congested. Ultimately, the resource is depleted because the total demand exceeds its rate of regeneration (Bromley, 1991; Stevenson, 1991).

The present work focuses on the possible relationship between group size and the occurrence of institutional change when common-pool resources are concerned. This involves a mixed-methods study aimed at developing the theory that there exists a critical group size threshold that drives institutional change. The study is grounded in the empirical analysis of several historical legal sources concerning the “*Carte Di Regola*” (Rural Charters and associated documents), private-order legal institutions for the management of the commons enacted by upland communities in the Italian Alps throughout medieval and modern times (1200–1800).

The remainder of the present chapter provides the background of the problem, the research hypothesis, the statement of the problem, the purpose of the study, the significance of the study, a summary of the elements of the methodology applied in the present study, assumptions and limitations of the research, and a summary of the contents of the subsequent chapters. A definition of terms used in the study can be found in Appendix A.

## **1.2. Background of the Problem**

Traditional solutions to the tragedy of the commons were the establishment of a private property rights system, or the enforcement of “command-and-control” policies; however, Elinor Ostrom (1990) overruled this conventional wisdom with a

different argument: societies are autonomously able to overcome social dilemmas like the tragedy of the commons. She contended that groups of users of a common resource may engage in cooperative strategies to avert the failure of collective action by self-governing their interactions. When self-organizing groups have the possibility of contracting their own covenants and setting up institutions, the tragedy of the commons may be averted (Ostrom et al., 1992).

**1.2.1. Historical case studies.** Historical case studies are valuable in the field of institutional analysis, as they render the effects and dynamics of institutions observable over an extended period of time (Diamond & Robinson, 2010; Greif, 2006; Voigt, 2013a). The *Carte Di Regola* case study is one of the most enduring cases of institutional success in the management of common-pool resources. Thus, the *Carte Di Regola* provide a unique facility to observe the behavior of groups in institutions using data from historical archives.

Despite limitations due to the nature of historical data, which can be affected by sample smallness or observation limited to certain periods, the *Carte Di Regola* include detail at the individual level, such as a single individual attending a village assembly, and at the village level, such as a village assembly of residents taking place. Such data allows precise measurements of formal institutional features but also provides a way to detect the moment when a switch from an informal to a formal institution has taken place (Casari, 2007; Voigt, 2013b).

**1.2.2. The *Carte di Regola* case study.** The present study builds on the work of Casari (2007), which provided the first empirical analysis of the *Carte Di Regola* as an effort to “examine changes in institutions that protected property rights and regulated their use in the commons in the Italian Alps and, more specifically, in the Trentino region, which is situated at the linguistic border with the German-speaking

South Tyrol” (p. 187). The case concerns the adoption of alternative management systems for the common pastures and forests through medieval and modern times (1200–1800).

The main reason for the emergence of legal institutions is the inherent cost of legal and economic transactions: the allocation of property rights always occurs under positive transaction costs (Coase, 1937, 1960; Demsetz, 1968; Williamson, 1979). Institutions, such as the *Carte*, are organized and evolve to attain an allocation of property rights that correspond to the highest possible social welfare (Allen, 2000; Demsetz, 1967; North, 1990).

### **1.3. The “threshold hypothesis.”**

The research hypothesis of this study is that there exists a critical absolute group size threshold that drives institutional change. The hypothesis posits (a) that group size has an impact on collective action, and (b) that this impact is not gradual and corresponds to a “switch” when group size is proximate to a threshold value.

The present research aims to identify possible “tipping points” in group size as well as to seek an economic explanation for group behavior when such a tipping point is reached. This tipping point is henceforth defined as the threshold in group size. When the threshold is reached, the group decides whether to adopt an informal interaction regime to formalize the collective action (North, 1990) by contracting an institution.

One way to validate the threshold hypothesis is to seek support for other hypotheses in diverse fields of literature that purport to provide a general prediction of the “optimal” number of individuals that can be involved in collective action situations. The argumentation for the group size threshold hypothesis in institutions

would accordingly develop as an extension of this general field of predictions to the realm of the social sciences.

There is general agreement among researchers that group size refers to the number of individuals in a social group. However, the size of a group depends on many factors, and is regarded as highly context-dependent in the literature (Hardin, 1968; Olson, 1965; Ostrom, 1990; Ostrom et al., 1992).

**1.3.1 The analysis.** Both direct and indirect tests of the hypothesis were conducted. The indirect testing comprised the rejection of alternative explanations contrasting with the threshold hypothesis. If the results of the analyses were incompatible with the threshold hypothesis, it would be rejected. If, on the contrary, the empirical evidence results were incompatible with the alternative hypothesis, it would be inferred that the behavior of the groups observed did not occur by chance. Three empirical aspects follow from the formulation of the hypothesis: (a) estimation of the critical size threshold, (b) determination of the institutional reactions of groups crossing the threshold, and (c) determination of the institutional features of groups beyond the threshold.

**1.3.2. The framework.** The starting point of the framework is the existence of a group facing a collective action problem. Statistical analyses are directed to disentangle the reasons for observed group size differences.

This dissertation considers two types of collective action in the commons: the appropriation of common resources, and the participation in the creation of institutions. The former is a process of direct extraction of resources by a group that is coordinated by informal rules of cooperation (or uncoordinated) and therefore at risk of collective action failure. The latter is a process of negotiation and implementation of management and governance rules for the resource use.

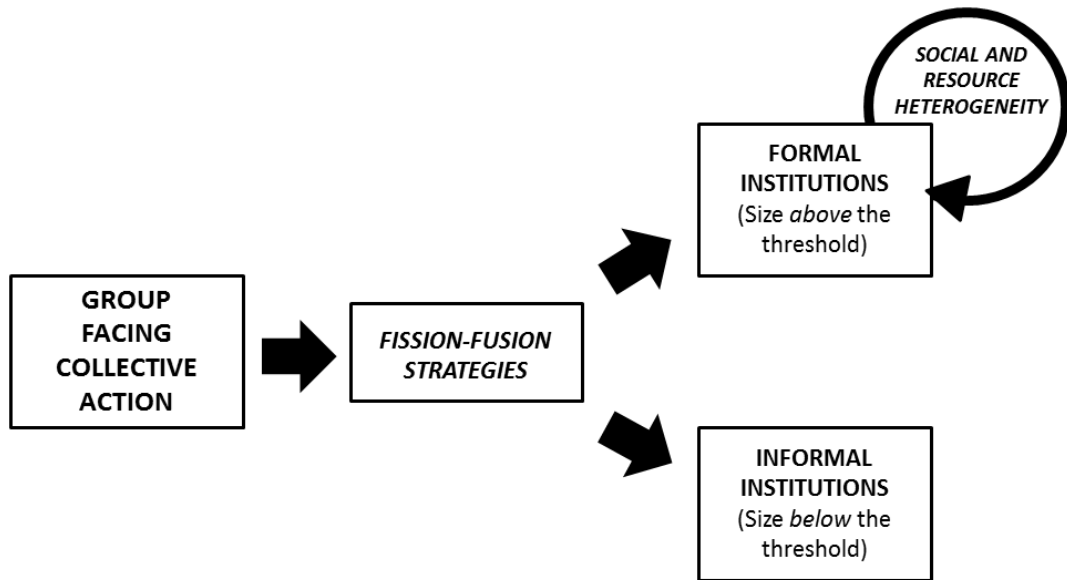


Figure 1.1. The framework.

Figure 1.1 illustrates the framework. The first type of collective action is governed by an informal institution, and is typical of groups having their size below the threshold value. The second type of collective action is governed by a formal institution, such as a rural charter, and is peculiar of groups that have crossed the group size threshold. The switch from an informal institution to a formal institution is an institutional change that is defined as “adoption of a formal institution,” or “transition to a formal institution.” “Fission and fusion” are group-behavioral responses to the crossing of the threshold. “Fission” implies a fragmentation of the group into two or more groups, which on their turn may (or may not) adopt a formal institution; “Fusion” refers to the emergence of a cohesion of groups under the adoption of formal institutions. The subsequent chapters will discuss these concepts in detail.



#### **1.4. Statement of the Problem**

A review of the literature revealed an incomplete and unbalanced body of knowledge about the possibility of a decisive moment in which a group has to choose whether to formalize the rules of the institution or not (North, 1990). The search failed to reveal any theory related to institutional change when a group reaches a “group size threshold.” The present research also contributes to the debate about the role of group size and heterogeneity in collective action, a theoretical and empirical challenge that Ostrom left for other scholars (2005b; Poteete, Janssen, & Ostrom, 2010; Varughese & Ostrom, 2001).

#### **1.5. Purpose of the Study**

This dissertation investigates the impact of group size on collective action and institutional change using the *Carte Di Regola* case study. Casari (2007) already suggested the relevance of group size for the emergence of formal institutions. As a preliminary stage, this dissertation successfully replicates this previous study.<sup>1</sup>

The present research supplemented the original dataset with additional data concerning property rights, content of the documents, organization of communities, population, assemblies, household size, land resources, climate and topography.

Using this dataset, the present author constructed a framework to address new research questions concerning the relationship between group size and the transition from informal to formal institutions. The research effort focused on potential explanations for the existence of a group size threshold capable of triggering a process of institutional change.

---

<sup>1</sup> The interested reader may find the results of the replication in Appendix B.

## 1.6. Significance of the Study

This dissertation is an empirical research in law and economics and new institutional economics. It contributes to the debate about the role of institutions as economic and legal responses to the ecological challenges faced by groups, especially where common-pool resources are concerned (Greif, 2006; Poteete et al., 2010).

The dissertation answers Williamson's (1979) call for further research, in that the existence of cognitive "triggers" in group size shows a difference between alternative institutional modes for organizing transactions. Numerous studies reveal how knowledge of group dynamics and individual cognitive limits sheds light on the economics of property rights and the evolution of self-enforcing institutions (Acemoglu & Johnson, 2005; Barzel, 1982, 1997; Coase, 1960; Libecap, 1989; Williamson, 1981). Nevertheless, despite a long tradition in the literature, the question of how formal institutions emerge remains of interest for lawyers, economists, and political scientists (Hume, 1739; Laveleye, 1891; Maine, 1861). The threshold hypothesis is a potential contributant to a comprehensive answer to this question. If successful, the present study would result in a framework for identifying a trigger of institutional change that could be used in further research even beyond the social sciences.

The emphasis placed on the intersections with behavioral and cognitive sciences—particularly to explain the existence of the threshold and its effect on group behavior, such as fission and fusion—renders the study relevant to an academic audience in the social sciences and to policymakers.

Table 1.1.

*Suggested reading paths*

Reader's interest	Suggested reading path
An overview of the research	Chapter 1 ; Chapter 9
Original research on 'Group Size'	Chapter 3 ; Chapter 5 ; Chapter 6
Original research on 'Heterogeneity'	Chapter 3 ; Chapter 8
Literature employed to ground the analyses	Chapter 4 ; Chapter 7
The case and the historical context	Chapter 2
Documentation of the research	Chapter 3

**1.7. Methodology**

The foundation of this dissertation was largely problem-driven and based on the structured observation of multiple case studies and village communities, which characterize the management of the commons in the Medieval and Modern Italian Alps. An important methodological aspect was the technical treatment of historical sources by mixing quantitative and qualitative approaches. The study of institutions involves a variety of disciplines and methodologies; this dissertation implemented a mixed-methods research approach, involving three distinct yet integrated research efforts.

In Chapter 2 the reader is guided through an exposition of the general problem of the management of the commons and of the specific case study. Chapters 4 and 7 offer a discussion of the theories of group size and heterogeneity in relation to common property. Chapter 5 develops a mixed-methods study to investigate the existence of group size thresholds. Chapter 6 uses grounded theory to describe fission and fusion behavior. Chapter 8 employs multiple regression analysis to understand the role of social and resource heterogeneity in formal institutions. Subsections 1.7.1–1.7.3 discuss in more detail Chapters 5, 6, and 8, which represent the bulk of the empirical analysis and of the original contribution of this work.

The discussion draws on a range of theories and results found in social science, focuses on a specific research question, and uses a research methodology that Poteete et al. (2010) described as a “customized path.” The overall goal was to allow the discussion to manifest an interdisciplinary breadth without losing depth of content related to theoretical and empirical problems. The content reflects the exploration and the interpretation of empirical evidence with a minimum use of theoretical modeling and with a discursive treatment of the technical aspects of the research, including econometric models, statistical testing, and computer simulations.

**1.7.1. Group size thresholds in institutions.** Chapter 5 first considered the determinants of group size in collective action. Five factors that may explain variations in group size were discussed: (a) resource specificity, (b) temptation to free ride on others’ effort, (c) transaction costs, (d) heterogeneity of individual preferences, and (e) cognitive limits. This chapter summarized relationships that can be explained in terms of transaction cost. The focus was on collective action in the use of common resources, where individuals interact face-to-face without indirect representation.

Potential threshold values were also investigated. A fertile body of literature in behavioral and cognitive science posits the existence of a “turning number” in group size. A study by the British evolutionary anthropologist Robin Dunbar (1993a) entitled “Co-evolution of neocortex size, group size and language in humans” initiated a body of literature involving field investigations, simulations, and experiments on primates. The aim of the research was finding a “critical” size in groups of face to face interactants that might correlate with cognitive limits. To wit, Dunbar found evidence that these limits, namely the neocortex ratio in primates and humans, formed the basis of the evolution of language (Dunbar, 1993b), bonding and hierarchical

structure in groups (Zhou, Sornette, Hill, & Dunbar, 2005), and the evolution of social networks (Hill & Dunbar, 2003; Kudo & Dunbar, 2001; Stiller & Dunbar, 2007). The results of Dunbar's research met with consensus in the scientific community.

Critically for the present research effort, the results also showed that cognitive limits might also influence the size and structure of institutions for collective action.

Dunbar's claim of the existence of a "social brain" in humans (Dunbar, 1998, 2003, 2009) was confirmed by neuroimaging results (Bickart, Wright, Dautoff, Dickerson, & Barrett, 2011; Powell, Lewis, Roberts, García-Fiñana, & Dunbar, 2012, Dunbar, 2012),<sup>2</sup> and formed one of the possible interpretations of the historical *Carte di Regola* system in the Italian Alps that was enacted between the 13th–19th centuries (Casari, 2007).

**1.7.2. Group fission and fusion in institutions.** Fission and fusion denote decisions undertaken by the group to sustain collective action under both the informal and the formal institutional regimes, and are treated in Chapter 6. The prediction is that when the group overcomes the critical size threshold, it will separate into two or more independent groups (fission) or, if two or more groups are too small to sustain collective action, merge into a larger entity (fusion). This chapter empirically investigated the relation between group division and the structure of institutions by reconstructing fission–fusion phenomena in a set of communities comprising more than one village for more than six centuries. The analysis focuses on the relation between the size of plenary face-to-face interacting groups, their internal structure, and institutional changes. The goal of the methodology was to derive evidence and test the hypothesis that fission–fusion strategies were employed to mitigate increasing transaction costs in the allocation of property rights.

---

<sup>2</sup> Chapter 4 contains a review of scholarly contributions on this issue.

### **1.7.3. Effects of group heterogeneity and size on institutional design.**

Chapter 8 considered factors that were deemed to influence the design of the formal institution, and ultimately of the collective action in the commons: the level of social and resource heterogeneity, and group size.

Social heterogeneity was measured as the fragmentation of the group in terms of individual surnames. Resource heterogeneity is a measure of the diversity of a community in terms of the portfolio of natural resources.

The study was an analysis of the relative influence of these factors on institutional design. Social and resource heterogeneity are expected to have an impact on both informal and formal institutions. However, the availability of historical sources made it possible to focus the research only on formal institutions.

The design of formal institutions crafted by the group is characterized by a set of institutional design features. The inner functioning of the formal institution is revealed by the analysis of rule content, rule balance, levels of complexity, the consensus within the group in reaching the collective decision, and stability over time of these decisions.

The leading conjecture of this chapter was that heterogeneity increases the costs of social contracting for defining and enforcing property rights. The diversity exhibited by self-governing communities who wrote and voted on community bylaws to manage their common resources was explored. Statistical analyses were conducted on a rich sample of coded bylaws and data about attendees in legislative assemblies.

## **1.8. Main results.**

The present research conducted to five main results.

1. The average number of individuals in villages remained stable, at 100–231 individuals (Dunbar’s range), despite that the general population growth in the study area tripled between 1220 and 1800. The population growth in villages was associated with the adoption of formal institutions, and the populations of villages adopting a charter were generally higher than those without.
2. The empirical analysis of institutional change identified threshold values in group size. This study’s estimates again exhibited a remarkable convergence with the results obtained by Robin Dunbar (1993a) in his research about human primate societies. In addition, results of computer simulations, corroborated by additional robustness checks, showed that the findings of the present study are in favor of the threshold hypothesis.
3. In large groups, subgroups handled collective action by organizing in no more than four organizational layers.
4. A puzzling finding is the absence of any significant correlation between resource heterogeneity and the considered institutional features.
5. On the contrary, social heterogeneity showed statistically significant impacts, especially on institutional complexity, consensus, and the relative importance of governance versus resource management rules.

## **1.9. Assumptions and Limitations**

**1.9.1. Assumptions.** There is a variety of assumptions upon which the overall validity of this study rests. Here the main ones are summarized. Assumptions are

grouped into six categories: (1) collective action, (2) communities, (3) property rights, (4) population growth, (5) production and information costs, (6) village assemblies.

1. *Collective action:*

- a. Groups preexisted before any collective action took place;
- b. A number of individuals convened in the same place have the potential to interact as a group;
- c. Individuals have bounded rationality (Ostrom, 1990, p. 25);
- d. Large and small groups do not differ as to punishment potential.<sup>3</sup>

2. *Communities:*

- a. The archives and the original sources incorporated in the study were complete;
- b. A community does not exist when no document has been written in that community that refers to that community;
- c. When a community does not exist, its resource endowments (corresponding to the cadastral units compounding the surface of the community) are assumed not to be used by the others; therefore, its absence in the dataset is allowed without loss of accuracy.

3. *Property rights:*

- a. The allocation of property rights occurs under positive transaction costs;
- b. The costs of creating a formal institution are fixed in relation to the size of the group;
- c. Once a community adopted a charter, the charter was enforced until 1800; that is, there was no return to an informal regime;

---

<sup>3</sup> See Section 5.2.3 for a discussion of this assumption.



- d. When a multi-village community transitioned to a formal institution by adopting a Carta, the effects of this adoption also involved its sub-villages;
  - e. All the observed institutional changes occurred voluntarily and were self-enforced;
  - f. Institutional changes occurred among an existing set of alternative choices and were never forced by external authority;
  - g. When the community did not have a charter, the existence of an informal regime was assumed;
  - h. Self-enforcement of the informal regime and of the *Carte* was perfect;
  - i. It is possible that the *Carte* may not be genuinely representative of the numbers and organization of the populace and commons; some corruption is likely, possibly in an effort toward tax avoidance or illicit gain as non-cooperative social behavior. However, although not directly observable in the data, such aspects of the data are presumed to be uniform and thereby have little impact on the findings.
4. *Population growth:*
- a. Population growth is exogenous to the process of institutional change; this assumption allows the consideration of changes in population as independent from the institutional type and organizational changes. It follows that institutions and organizations adapt to increasing or decreasing population growth: in particular, groups with larger initial populations are assumed to have faster technological change and population growth (Kremer, 1993).

5. *Production and information costs:*
  - a. The production function of a community is composed of labor and land inputs and exhibits returns to scale that initially increase and then decrease with group size;
  - b. Common resources are always harvested at fully cooperative equilibrium, independent of the institutional regime;
  - c. At any time, the amount of resource harvested by the group is equal to or less than the sustainable resource production: total effort and labor are constant at the optimal level;
  - d. Once a formal institution is adopted, the total rents from production remain constant when group size increases;
  - e. There are different information cost structures in different resource settings;
  - f. After the adoption of a formal institution, there was no resource specificity in production efficiency.
  
6. *Village assemblies:*
  - a. There was no distinction between a constitutive quorum (the number of quorum members required to consider the assembly valid) and a deliberative quorum (the number of attending members required to consider the decision valid);
  - b. All members were obliged to attend the assembly; therefore, it was not necessary to specify compliance to a constitutive quorum;
  - c. After making the collective decision in the assembly, its implementation was automatic;

- d. Only village representatives, and not the totality of the villagers, attended the higher assemblies of multi-layered communities.

**1.9.2. Limitations.** A limitation of the study was the nature of historical data, often affected by a small sample of observations for a certain period and limited to the community level. Two additional categories of limitations concern assumptions made for creation of the dataset, and assumptions made for the interpretation of the data.

The creation of the database used in this study relies on six assumptions. The first is about the quality of data: the data collected from published sources was error-free, that original sources were error-free, and that first-hand data from archival sources was free of clerical and measurement errors. The second is about completeness: the list of the documents used for the analyses was complete and fully descriptive of the institutional changes that occurred in the Trentino region during 1200–1800. The third is about the absence of self-selection bias: the subset of 260 documents used to study the effects of heterogeneity of institutions was representative of the whole set of charters and unaffected by self-selection bias. The fourth is about the internal consistency of coding: the categories adopted in the grounded theory study and in the coding of the content of the subset of 260 charters in Chapter 8 were mutually exclusive and complete. The present coding categories reflect an interpretation of historical data by a researcher assumed to be unbiased, but different criteria could have been adopted.

A set of four limitations relates to assumptions made for the interpretation of the content of data. The first is about the analysis of the documents which guided the reconstruction of the transition of villages and communities to formal regimes, as well as the reconstruction of group fission and fusion behavior and the consequent internal organization of communities. Such interpretation is technically correct insofar as the

data is correct; however, it was assumed that other interpretations might be possible using different categories and frameworks. With access to the original documents, the interpretation in the present study faithfully portrays the historical events as documented in the sources.

The second is about the production of population estimates, and contains a number of second-level assumptions. Community population was studied using estimates instead of real data. As in Casari (2007), estimates were computed by backward projecting the community population for each desired year starting from the 1810 Napoleonic Census data and using the Italian population trend (Bellettini, 1987). This methodology implicitly assumes equal population growth in all the communities. It also neglected any effect of internal migrations between communities: this limitation may potentially lead to duplicate observations of the same individual in two different communities or the same individual being undocumented in one or both; this is controlled case by case and not completely eliminable. Population estimates included community members (insiders) and outsiders. The number of insiders was estimated using assembly attendance; the assembly quorum (observed, or the pondered average of the observed quorums when a quorum is not observed) was estimated by assuming a constant household size of five. This latter assumption was based on constant fertility levels across communities and across time.

The third is about the reconstruction of informal institutions. The impact of social and resource heterogeneity is measured only on formal institutions. Social and resource heterogeneity is unobservable in the historical informal institutions of the present study. Similarly, no predictions on fission and fusion on multi-village informal institutions could be made, as they are likewise unobservable. Therefore, it

was assumed that multi-village institutions were generated only after a formal institution was adopted.

The fourth is about economic outcomes. The present study did not directly observe the economic outcomes of institutional choices. Therefore, claims as to the economic success or efficiency of institutional choices cannot be proven on empirical grounds, and thus fall outside the purpose of this dissertation. The results are in the form of statements of compatibility with the observed evidence in support of, or in contrast to, previous economic and social science theories, statements of convergence/divergence of results with other empirical and theoretical studies, empirical statements on probability and correlations, and are only explain causal links between variables.

#### **1.10. Structure of the Remainder of the Dissertation**

The dissertation consists of four parts. The first part consists of three chapters: Chapter 1 outlines the research effort; Chapter 2 describes the case study; Chapter 3, discusses the data sources that were accessed in the research.

The second part consists of an investigation of the existence of a group size threshold, spanning Chapters 4–6. Chapter 4 contains a discussion of theories cited in the literature about group size, thresholds in collective action, fission–fusion strategies, institutions for property rights on the commons, and institutional change and sets the background for the formulation of the threshold hypothesis of institutional change. Chapter 5 contains a discussion of the identification of the group size threshold and of its determinants. Finally, Chapter 6 is a discussion of the role and rationale for fission–fusion strategies.

The third part includes Chapters 7 and 8 and encompasses a discussion of the internal functioning of formal institutions beyond the threshold with a particular focus

placed on the determinants of institutional design. Chapter 7 contains a discussion of literature related to group heterogeneity and institutions, with a particular focus on the study of resource management and collective action. Chapter 8 is dedicated to the role of social and resource heterogeneity and group size in forging institutions. See Table 1.1 below for guidance on relevant chapters based on research interest.

Chapter 9 offers a synthesis of the findings as well as a discussion of the implications and potential further studies.

## Chapter 2: The *Carte Di Regola* Case Study

*These are not abuses, they are not privileges, they are not usurpations: it is another way of possessing, another system of legislation, another social order, one which, unobserved, has descended to us from centuries long past.*—(Carlo Cattaneo as cited in Grossi, 1981).<sup>4</sup>

### 2.1. The Governance of Upland Commons

The present chapter is a historical review of the emergence of institutions for the management of the commons with a European and global perspective (Section 2.1). After briefly illustrating the history of village communities in the Italian Alps between 1200 and 1800 (Section 2.2), this chapter outlines the case of the *Carte Di Regola* (Section 2.3). Particular attention is drawn to the reconstruction of the conditions that allowed the enactment of the *Carte Di Regola*. Section 2.4 summarizes and concludes the review.

The present-day understanding about the governance of collective action, particularly in the context of common-pool resources, is profoundly indebted to Elinor Ostrom's works (Ostrom, 1990; Ostrom, Burger, Field, Norgaard, & Policansky, 1999). These researches provide a global outlook that demonstrates how institutions for the management of the commons emerged and developed in very different settings, at different times, with similar characteristics in design and structure.

Legal scholars seem to have rediscovered the common characteristics of such institutions only in relatively recent times, although a substantial body of literature on common property has been written in the past two centuries. Before Ostrom (1990), scholars expressed skepticism toward the possibility of overcoming collective action

---

<sup>4</sup> The work was first published in Italian (Grossi, 1977). Cattaneo was speaking of the vestiges of collective landholding structures in *Su la Bonificazione del Piano di Magadino* (On the Redevelopment of the Magadino Plain).

problems (Olson, 1965) on the commons (Hardin, 1968) without the conversion of collective landholdings into private property or, alternatively, through direct government regulation. Despite scholarly skepticism, the period ranging from the end of the 19th century to the first decades of the 20th century was a fertile period for the study of the commons among lawyers and economists. Further studies are the result of these first contributions to the fields of legal theory and the political economy of property.<sup>5</sup>

The first contemporary legal scholar to understand the importance of common property as a natural institution was Henry Sumner Maine, who wrote *Ancient Law: Its Connection with the Early History of Society, and its Relation to Modern Ideas* (1861). The book is the earliest empirical inquiry on common property institutions of many populations around the world. In another book, *The Effects of Observation of India on Modern European Thought*, Maine observed the following:

The facts collected suggest one conclusion which may be now considered as almost proved to demonstration. Property in land as we understand it, that is, several ownership, ownership by individuals or by groups not larger than families, is a more modern institution than joint property or co-ownership, that is, ownership in common by large groups of men originally kinsmen...

Gradually, and probably under the influence of a great variety of causes, the institution familiar to us, individual property in land, has arisen from the dissolution of the ancient co-ownership. (1875, p. 227)

Another important contributor was Henri de Laveleye, professor of political economy at the University of Liege and author of *De la Propriété et de ses Formes Primitives* (1891). This book went beyond a treatise on property: it explicitly tackled

---

<sup>5</sup> For a celebrative review of the importance of the work of Elinor Ostrom for lawyers, read Fennel (2011).



the issue of common property and became an invaluable contribution in terms of critical analysis of the capitalist society based on natural law. Laveleye developed an important critical analysis of the Romanist origins of the concept of ownership. His view was similar to Maine's and represented a first example of legal and comparative economic analysis of common property. Cases cited in Laveleye's work and reported by Grossi (1981) included the Germanic *Mark* (p. 71); the Russian *Mir* (p. 9); the Javanese *desa* (p. 49); the British *township* (p. 267); the Germanic, Swiss, and Scandinavian *Allmend* (p. 201); and the southern Slav *zadruga*—all of which were institutional forms that escaped the rigid Romanist dogma of the *condominium* or the *universitas* (p. 299). Rather, they were examples of “living,” dynamic, “universal” institutional languages, which Grossi termed “alternative ways of possessing.” Grossi contended the following:

...it would be unacceptable to speak of property in the singular, as the jurists and before them the philosophers had done. Their property was now one property, one of the many forms of appropriation that men had devised and set up as they lived through their history. Other forms had been and could still be proposed in response to differing origins. (p. 67)

Grossi quoted Laveleye:

Another very widespread error is to speak of “property” as if it were an institution having a fixed and immutable form, whereas in reality it has taken on the most different forms and is still susceptible to very great and unforeseen modifications. (De Laveleye, 1891, p. 381)

Maine and Laveleye ignited the European controversy on the importance of common property rights at the outset of the current legal system, which is conceptually based on the centrality of private property. Researchers have underlined

how private property was established as the pillar of civil society after the Enlightenment and the Industrial Revolution in England, where the land tenure system swapped after 600 years from the open fields to private property (Grossi, 1977, 1981, 1990). Grossi concluded that during the Enlightenment and in the late 18th century, known as the “Age of Codification,” the sole proprietor was awarded a moral superiority over the nonproprietor in social, political, and juridical theory. The legal theory at the core of the works of preparation of the Civil Code ignored any form of joint ownership on political and philosophical grounds by projecting the “shadow” of quiritian (Roman) property into the new forms of property best suited to the newly forged French bureaucratic apparatus.<sup>6</sup>

According to Grossi (1981), in Europe there was a direct identification of proprietorship with citizenship and proprietorship with the capacity of exercising civic rights and virtues; individual ownership was the symbol of all the virtues, liberties, and rights of the citizen, which represented the best of all the possible situations in which a man could find himself in relation to goods and society. The ancient open fields system continued developing undisturbed in many other places of the world (Grossi, 1981). However, collective ownership was regarded as a deformation of the norm, representing a juridical deviation, and was often associated with the customs of uncivilized populations. A number of later contributions focused attention on resource management institutions in the Alpine area or similar settings elsewhere in the world (Ostrom, 1990). Settings similar to the Alpine environment with similar institutions were explored by the political scientist Samuel Popkin, who wrote a seminal book on rational choice theory using the case of village institutions in the rural society of contemporary Vietnam (Popkin, 1979).

---

<sup>6</sup> The economic consequences of this abrupt political shock were investigated by Acemoglu, Cantoni, Johnson, and Robinson (2011).

Other studies focused on settings similar to the Alpine one, such as the northern Indian village institutions in the Himalayas (Agrawal, 1998; Agrawal & Chhatre, 2006; Baland Pranab, Das, Mookherjee, & Sarkar, 2006; Baland & Platteau, 1996; Chakravarty-Kaul, 1996). Another key contribution was written by Robert McNetting concerning the village of Torbel in Switzerland (Netting, 1981); his work inspired many other authors in the study of upland village communities. The economist Robert Wade (1988) studied modes of public policy and the society in “village republics,” explained the economic conditions for collective action in contemporary South India, and referenced many other cases of successful management of the commons. Netting (1972) studied a Swiss case, McKean (1984) studied a Japanese case, and Campbell and Godoy (1985) studied the open-field system in the present-day Andes as well as Medieval England. Despite these cases of commons management certainly exhibit differences with the *Carte Di Regola*, both as to their institutional history and the context in which they arose, they share similar physical characteristics, the same collective action problem, and analogous solutions.

A key reference for the Eastern Alps was written by Cole and Wolf (1999), two American anthropologists who identified an ethno-linguistic frontier in the southern Tyrol and the Trentino region by analyzing the ecology and the origins of the ethnicity of the present-day area of the Valley of Non between Trento and Bolzano. This contribution was used as one of the references for the data provided on population in the present study. A precise reconstruction of the environment, population, and social structure in the Alps since the 16th century was written in a study by Pier Paolo Viazzo (2006) concerning the village of Alagna, which defined the Alps as a “magnificent laboratory” for social scientists. The conclusions of all such cases are similar. In Wade’s (1988) words: “These cases are sufficient to negate

the necessity of full private property rights or for control by a central authority in order to protect common-pool resources” (p. 199).

A collection of historical studies on the management of common lands in general (not only the Alps) in North-western Europe was published by Tine de Moor, Paul Warde, and Leigh Shaw-Taylor in 2002. The studies were authored by a number of contributors and covered (a) France, the Flanders;<sup>7</sup> (b) northern and southern England; and (c) the Netherlands, Sweden, and south and northwest Germany from c. 1500–1850.

Such studies are gradually unveiling a rich heritage of common property institutions that were in force (and, in some cases, are still in force) on the European continent for centuries before the Enclosures and the French Revolution. Note the Italian case of the *Partecipanza Agraria di Nonantola* in northern Italy, whose origins are traced back to the 10th century (Alfani, 2011).

The rich European panorama of common property is also reflected within the boundaries of the Italian peninsula. Grossi (1981) illustrated some of the institutions for collective action in the commons that were in force in Italy during medieval and modern times in both the north and south. Grossi also noted that the Italian legislators in the late 19th century were aware of the existence of these institutions, which often differed according the region of emergence. In the north, these institutions appeared more linked to a participative “community” (the commons were called generally “*beni comunali*” or “*ademprivi*”, transl. communal goods), while in the southern part of the peninsula, particularly on the islands of Sicily and Sardinia, the institutions for collective property were more hierarchically organized and associated to large estates (*latifondo*). The commons in central Italy were largely affected by the establishment

---

<sup>7</sup> See also De Moor, 2009.

of *comuni* (independent cities) during the 11th century, when urban institutions developed on a voluntary, spontaneous basis (sometimes led by local aristocrats) having as rationale the thrust for local freedom and self-governance from feudal dominations and bounds (Andreatta & Pace, 1981).

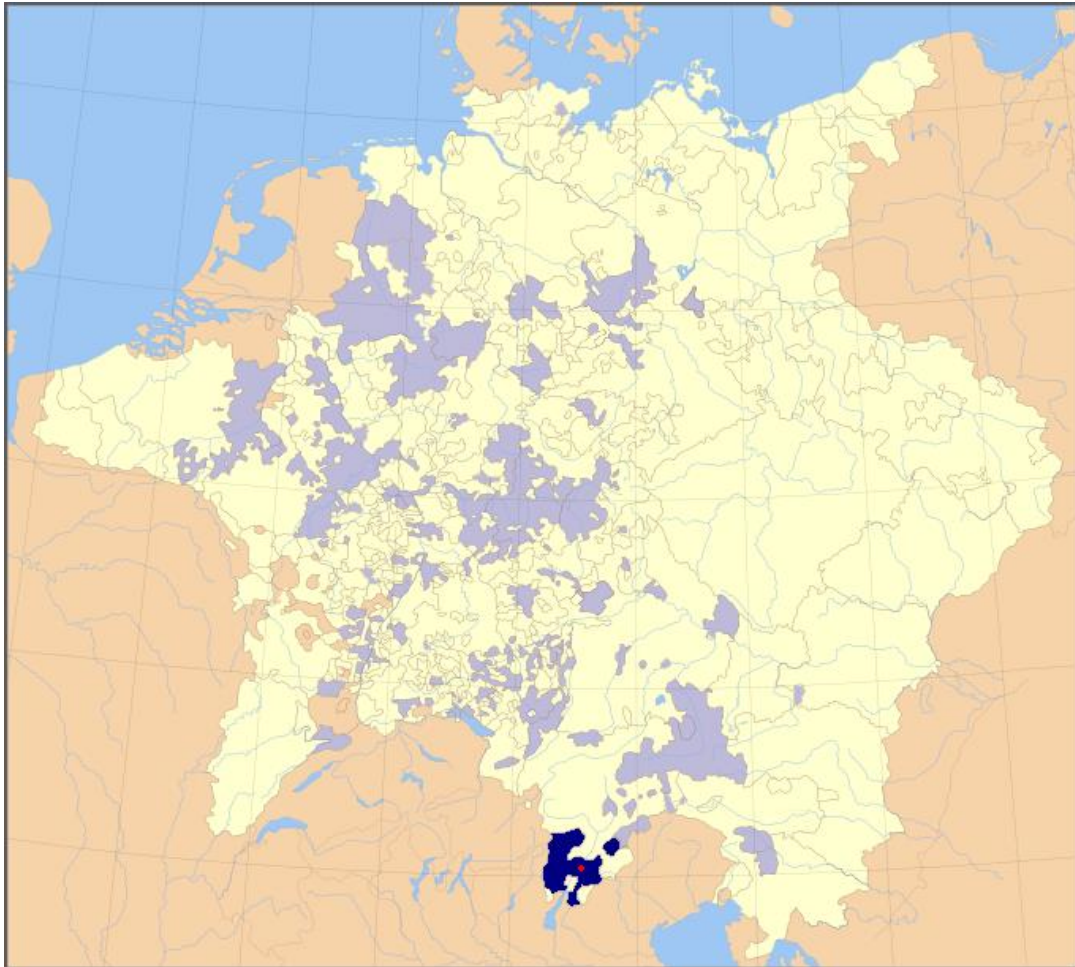
In general, communal goods in Europe were divided and organized in concentric circles around the villages and were collectively owned by different kinds of institutions, such as the *Carte di Regola* in the Italian Alps (Casari, 2007).

## **2.2. Village Communities in the Italian Alps, c. 1200–1800**

The following is a brief historical overview on the political, economic, and legal institutions of the prince-bishop of Trento in c. 1200–1800, which comprises the case study that formed the foundation of the present study. The region and the emergence of settlements are described. The political economy of the village communities, the land tenure system, and the main historical events that affected the institutions and the economy of the region in the six centuries before the abolition of the regime in 1804 are summarized.

The Bishopric of Trent (Figure 2.1) was a principality of the Holy Roman Empire; the bishopric was a 2,400 square-mile area located in the Alpine area between the German-speaking area, or Tyrol, and the Republic of Venice. It was a territory roughly corresponding to the current Province of Trento in northern Italy. From 1027 to 1803, the prince-bishop of Trento, appointed jointly by the Holy Roman Emperor and the Pope, granted villages autonomy in governing collective resources as well as in other internal issues concerning community life. An extensive description of the economic history of the principality is contained in two volumes of the *Storia del Trentino*, one that was edited by Castagnetti and Varanini (2004) for medieval

times, and another by Bellabarba and Olmi (2000) for modern times (until the secularization of the prince-bishop).



*Figure 2.1.* The Bishopric of Trent, 1648.

*Note.* Map of the Holy Roman Empire, 1648, with the territories belonging to the prince-bishop of Trento/Trient highlighted. Trento is represented by the single dot. Ecclesiastical lands are shaded in pale blue. Source: modified from File:Holy Roman Empire 1648 Ecclesiastical.png; boundaries inferred from Tirol-Atlas (edited by A. Leidlmair, Innsbruck: Universitätsverlag Wagner, 1985), Part F - Geschichte (F. Dörrer, P. W. Haider, F. Huter, W. Keller, & W. Leitner), specifically maps F6 (Territoriale Entwicklung, F. Huter & W. Keller) and F9 (Verwaltungsgliederung 1766, F. Dörrer & W. Keller). Authors: Roke (map), Hanno Sandvik (addition of colors). Available at: [http://en.wikipedia.org/wiki/File:HRR\\_1648\\_Trient.png](http://en.wikipedia.org/wiki/File:HRR_1648_Trient.png). Permission (Reusing this file) released by the author under GNU.

**2.2.1. The rise of the rural community in the Italian Alps.** For centuries, the Trentino was characterized by settlements in the form of small communities. Casari (2007) asserted the median community population in 1810 was just above few hundreds inhabitants. Villages were built around the church and the main square. Distances between villages were sometimes covered with great difficulty, given the tortuous paths that linked them. The *potestas* (domain/area of influence) of the prince extended over the entire region where many settlements were scattered. The community became the production unit of the State, typical of the southern part of the Tyrol (Cole & Wolf, 1999; Viazzo, 2006), and was a close-knit group governed by strong family ties (Barzel, 2001; Ellickson, 1991).<sup>8</sup> The territorial government relied on the enforcement of religious norms in a network of local churches in several of these communities, which were directly accountable to the Bishopric in Trento.

The first settlements in the Trentino region had early origins, but not before 222 B.C. (Andreatta & Pace, 1981). During the Roman Empire, the territory was divided into four *municipii*: (a) Trento, Feltre, and Valsugana up to Pergine; (b) Verona with the Low Val Lagarina; (c) Brescia; and (d) the Garda Lake region up to Arco. In 49 B.C., the importance of Trento had grown so much that Julius Caesar extended Roman citizenship to those in the region first and later the title of “Municipium” to Trento.

Settlements gradually developed around the town or urban center and were scattered in the region up the floor of the most remote valleys. These settlements were called “pagi” and “vici” and grew in number in relation to regional population growth until they occupied the whole region. Settlements were eventually established at higher altitudes. Initially, these settlements were the primitive basis of the collective

---

<sup>8</sup> Barzel studied the characteristics of groups in terms of transaction costs (Barzel, 2001, p. 69) and defined a close-knit group as “a social entity within which power is broadly dispersed and members have continuing face-to-face interactions with one another”(Ellickson, 1993, p. 1320).

life of a few families, and they later evolved into villages termed “Villae” or “Viciniae” (from *Vicus*), established with the primary aim of organizing the collective services necessary for survival (Varanini, 2004).

The evolution of these settlements into “communities” is linked to the rise of the *comuni* in central Italy around the year 1000. These institutions spread from the major Italian urban centers in northern Italy and diffused during the 13th century into the Trentino region. Legal documents establishing the new institutions were often “charters of liberties” containing the right of the inhabitants to write their own statutes and to elect their own rulers. The most frequently adopted forms of community governance were based on a *console* (consul), which reflected the stature of privileged families; the *Podestà*, which represented a foreigner; or under the government of *Capitani del Popolo* (Captains of the Populace), a *Signorie* (Lordships), or *Corporazioni delle Arti* (Guilds) (such as in Florence).

The rural community form followed a similar track, but it is regarded by historians to trace back to earlier than the Roman domination (Andreatta & Pace, 1981). While the urban community developed as a spontaneous entity to manage concessions from the local feudal lord, the rural community emerged often for (a) religious ends, (b) the defense of the group’s common interests, (c) the organization of the use of the common resources, and (d) the organization of trades and commerce necessary for the survival of the population. The librarian and intellectual Tommaso Gar recalled that when Saint Vigil, Catholic missionary and third Bishop of Trento, came to evangelize the populations of the Adige Valley, he found the population already concentrated in small villages grouped by a highly variable number of families (Gar, 1860). These pre-existing settlements had common economic rights on



ample expanses of forest and pasture, linked by family bonds, membership, and mutual cooperation.

**2.2.2. Village economics.** The climate in Trentino was very unsettled and varied with the altitude where the villages were located. Cold winters and the prevalence of mountainous areas with steep slopes resulted in agricultural production of only 8% of the total Trentino geographical area where there was, by necessity, little diversification in agricultural production. Vineyards and farmland were mostly individual property, while the forests, meadows, and pastures were mainly collectively owned. Forests covered about half of the area and were important sources for firewood, building materials, and materials for handicrafts (e.g., furniture, wheels, and wagons). Meadows and pastures covered about a third of the territory and were devoted to farm and dairy production. The expansion of the arable land was subjected to favorable climatic conditions over time and by area (Coppola, 2002a; Varanini, 2004).

Collective goods, particularly grazing land, belonged to one or more communities. Grazing lands, forests, and mines were collective goods of the utmost importance in the production cycle of communities. Grazing land and forests provided the population with a complete food source: game, poultry, and grazing animals. Feeding cattle and sheep was problematic in the economy of communities, as grazing land was limited to low altitudes due to seasonality. Conversely, large blocks of grazing land meant the possibility of developing commercial cheese. Furthermore, the production of wood was strategic for commercial relationships with Trento and the outside world. Timber traders from Verona, Brescia, and Venice (and later from Innsbruck) required good relationships with the local powers in the Trentino region to guarantee the supply of wood. Forests were a resource that had slow growth

(Castellani, 1982; Clark, 1990) and needed a “planned extraction” to avoid resource overexploitation.

Entrepreneurs and traders had to maintain relations with the prince-bishop to access the products coming from the mining sector. The presence of minerals and metals in the mountains of Trentino was another source of wealth for many communities between 1100 and 1200 A.D. However, mining activity was conducted with some difficulty because of the technical limits of the time; excavating the land or driving wells to even a modest depth was difficult (Sabbatini, 2002; Varanini, 2004).

During c. 1400, rural communities found in the commons an important source of wealth. The discontinuous expansion of agricultural products and the distribution to the head of families of zones of forest that reduced agricultural space can be considered the first attempts toward the privatization of collective assets. In the rural charters of c. 1400, it is possible to notice an increase in the restrictions for the governance of grazing lands; for instance, (a) prohibition of access and use by outsiders (*forestieri*), (b) limitation of use and management only to insiders (*vicini*), (c) compulsory community herding, and (d) strict determination of the spaces devoted to forests and of the pathways used to reach them.

Commercial relations underwent acceleration in the 12<sup>th</sup> and 13<sup>th</sup> centuries with the growth of Verona, where many traders who made their fortunes by commerce in timber resided. The 14<sup>th</sup> and 15<sup>th</sup> centuries ended the monopoly in the basin of the River Adige, which led to the subsequent decline of the exploitation of forest resources of other basins. The transport always took place through the Rivers Adige, Chiese, and Sarca. The transport of timber via rivers in 1400 was especially prevalent in Val di Fiemme. During the 15<sup>th</sup> century, forest management was made up of a complex system of practices of cutting trees according to a “schedule” that

ensured the regeneration of the vegetation (Agnoletti, 1993, p. 75). These practices were traditionally passed down by word-of-mouth (informal institutions) or statutory regulations (formal institutions) and seemed to find definition and compliance during the 15th century.

Historians report that, in 1558 and in 1583, the prince-bishop issued a directive to protect the forest wealth. The management of the Valle di Fiemme was intended to limit the deforestation with rules aimed at the stabilization of extraction quantities (Coppola, 2002a, b). The enforcement of the right of collecting firewood (in various forms, such as the *sorte*, which was the entitlement to a fixed proportion of cut product from the common forests for the residents in the jurisdiction) satisfied the domestic demand for heating, construction, flooring, roof shingles, the domestic production of handcrafted tools, and use in the manufacture of charcoal and lime. Byproducts of the forest areas came from conifers: turpentine and resin were very profitable, and a significant tax was imposed on them (Sabbatini, 2002; Varanini, 2004).

The production of timber for commerce evolved differently in the valleys in Trentino and was intended to feed the market throughout northern Italy, especially in the building and shipbuilding sector. As anticipated, the transport was provided by a system of timber rafting on rivers. Several smaller rivers such as the Leno, Sarca, Chiese, and Noce connect the Tyrol to the Trentino region for timber rafting. Particularly, the River Sarca connects the Tyrol with Riva del Garda. The connection with the River Brenta brought the production of the Valsugana and Val di Fiemme to the foothills near Vicenza. The economic return was substantial: the communities derived considerable concessions for the exploitation of the forests. Princely taxation consisted of duties, delivery charges, and logging rights; for example, Sabbatini

(2002) reports that the timber trade of the Val di Fiemme yielded 5,000–6,000 florins a year, plus the firewood. At the beginning of 1600, the economic interests of the county of Tyrol for the duty of Lavis were quantified as 100,000 florins a year (Sabbatini, 2002).

During c. 1200 to 1300, the vast land of the area began to be used seasonally for agriculture (Varanini, 2004). The creation of stable settlements was slower, and in this period, the high Alp (grazing herds above 10,000 ft.) was inserted in the productive cycle.

During the 15th century, important manufacturing and production services and non-agricultural production activities arose. The occupational and social fabric of daily life in communities was comprised of innumerable part-time jobs. These activities were generally related to seasonal or temporary migration. The first corporate organization of wool production and commercialization was recognized only in the first quarter of the 15th century. The Statute of Trent in 1523 recognized with favor the status of the merchants of Trent. In this period, the diffusion of the planting of mulberry trees arose, essential for the growing of silkworms.

Growing cereals such as rye was suitable for difficult terrain and harsh climates. Autumn-sown cereals, legumes, and fruit trees were prevalent in the valley of the River Adige. In terms of agricultural innovations, new crops were introduced during the 17th century. The introduction of corn, due to its high productivity, alleviated, but did not solve, the subordination to the external grain market from the River Po, and the Veneto in particular. The orientation of agricultural practices was toward simplification. The introduction of the new crops allowed for frequent alternation between wheat and corn and the subsequent elimination of periodic rest for the land. Profitability of the land was little affected, however, and the new

introductions contributed to the stabilization of soil fertility (Coppola, 2002a; Sabbatini, 2002). The negative side of simplification in agriculture was the spread of a disease, pellagra, which was the result of the simplification of eating habits, especially in the poorer classes, and endemic in northern Italy at that time (Hampl & Hampl, 1997; Latham, 1973).<sup>9</sup>

Wine production made a leap to modern techniques and products in the 1500s and in vineyards in the 1600s. In the 17th century, the development of the wine sector was vigorous, especially in trade. The land devoted to vineyards cultivated below 750 meters above the sea level in the early 18th century quadrupled in some areas. Wine was traded for grains of German origin. Tobacco was another introduction of the 17th century, together with potatoes. These innovations in the agricultural sector had a positive impact on production. At that time, actual production was lower than potential production because of the absence of fertilizers and the difficulty of irrigation between breeding the cattle and farming. The backwardness of agronomic knowledge, agricultural limitations imposed by contract choice, and lack of capital for investments in production were the main reasons for the low productivity of land. Furthermore, a large workforce was required. The growth of silk production and the increase in the cultivation of mulberry trees for silkworms as well as the growth of wine production led to an expansion of the farmland at the expense of pastures and meadows (Sabbatini, 2002).

Other innovations concerned the relationship between animal husbandry and the farm. In the 16th century, sheep farming decreased because of the general decline of wool production, and driven by low-cost imports of German-made wool from the Tyrol area. Cattle grazing was instead developed in the middle-high mountains. The

---

<sup>9</sup> For nutrition habits and anthropometric history of Lower Austria in the 19th century, see Komlos (1989).

use of agricultural contracts, such as the lease, led to an organization of livestock production that allowed the building of stables and other facilities, such as warehouses for butter. The limitations of this system derived from uncertainties, such as a bad season, that could reduce the amount of hay produced, or sometimes epizootics that might reduce the cattle population, especially if the region was involved in military operations; for instance, as happened in 1734. Despite these limitations, the production system was stabilized in the 17th century (Sabbatini, 2002). During the 18th century, a few modest changes took place to ensure maintenance of a balance among resources and people. Changes in agriculture were significant and showed a tendency to overcome the structural weaknesses toward a more efficient system. A first change was the reclamation of wetlands along the River Adige. Waterways were also a problem in the 19th century; however, there were many areas of redemption for landowners, or for the public interest.

**2.2.3. Land tenure system.** Contractual solutions between users and local aristocrats varied with altitude: lease with rent in kind, rent in kind, *enfiteusi* and *livello* (particular and ancient forms of agricultural lease), and perpetual lease were some of the forms. These contracts underlined different agricultural contexts and different social relationships (Stella, 1958), although the absence of any indication about land demarcation did not facilitate the determination of the relationship. The logic underlying the contract was straightforward: on the one hand, the owner of a stock of food was safe from market fluctuations, and on the other hand, the appropriation of commercial products, such as grapes, took place (Coppola, 2002a).

Historians report that the different types of contracts fulfilled two economic interests: the owner's to a constant annuity, usually given in kind or parameterized, and the conductor's to the self-management of the land that, beyond the unavoidable

obligation to improve the land, allowed the long-term appreciation of the improvements and, eventually, the right or redemption of the land itself. The contract, however, often hid a financial rationale (security) rather than a rent (“simulation”): this was the case of the “simulated sale” that corresponds to present day “sale and lease back” agreements (Coppola, 2002a).

The “simulated sale” contract worked as follows: a person sold land to another person and simultaneously, in addition to the amount received, undersigned a term that obligated the seller to sign a lease contract to use the land and to pay a rent equal to the interests accrued; in addition, the seller contracted with the buyer for the sale-back (in the end, the original seller had to buy back the estate). This solution obligated the seller to a rent in kind, and was substantially a loan that circumvented the precepts of Canon law on usury (Coppola, 2002a, p. 240). Frequently, upon exercise of the sale-back, the original seller was not able to buy-back the land, and the operation ended with an expropriation. The price of the sold-out land was the amount lent under the contract, but the same land was immediately rented to the seller. The rental corresponded to the definition of “moneylending.” Other times, the contract had a virtuous purpose: in the “middle mountain,” the *masi* (Alpine farmsteads) were assigned to households for periods of 19 to 29 years with the option of renewal.

Frequently, the contract allowed the cultivation of other crops than those strictly specified in the contract in consideration of rent paid, affording the peasant a higher degree of discretion that maximized the productive potential of land.

A new regulation regarding the development of the livestock sector modified the contracts on livestock and cattle grazing for the purpose of limiting the negative consequences of an excessive load of cattle, which was pertinent for participation in the communal exploitation of forest and grazing resources. In the valleys, the

expansion of cultivation (due to population growth and the consequent increase in demand) affected the feeding of livestock. The lack of summer pastures did not allow the massive growing of cattle, which cannot be fed during winter with fodder. Fodder was kept up to the threshold that allowed the sustainable yield of the land and a modestly profitable sale during the winter. Downstream communities usually let their herds be grazed by professional herdsmen on the mountains during summer. This solution was very common, but with a low margin of profitability. Collective ownership in the middle mountain was rather widely diffused. The most common forms of livestock were cattle and sheep. There were local herds and flocks coming in from foreign areas. The communities that had most of the pastures and management of pastures found it cheaper to rent them to outsiders than to sustain them. Normally, the statutes and rural charters contained prohibitions against foreign herders in the commons, and these rules were intended to preserve resources and avoid the overexploitation of land.

A possible explanation related to production was also that grazing lands were more abundant than meadows. The underlying concern was the supply and retention of a significant stock of fodder to be used during the winter. Consequently, stocking was commensurate with the need to avoid damaging it.<sup>10</sup> The area of pasture was extended as much as possible, to the detriment of other types of ground cover, so that some communities, such as the *Val di Fiemme*,<sup>11</sup> provided some rights to use the marshes of the Adige valley for a few months when the pastures were already (or still) covered with snow. In these situations, of course, the exclusion of foreign flocks was vital. When the thaw freed the area of high-altitude pastures and began the period of the Alp pastures, a surplus of food allowed more cattle than the one locally present.

---

<sup>10</sup> Archivio Comunale Storico, Lomaso, 26, *Instrumento de sentenze de le malghe*, 1535, c.1.; see also: Archivio Comunale Storico, Lomaso, 8, *Instrumento del modo de malgeazar*, 1549

<sup>11</sup> Archivio della Magnifica Comunità di Fiemme, Cavalese, Drawer G, 18:28, 15 March 1640



Hence, the exclusion of foreigners to access the common goods became more relaxed: outsiders were allowed to graze their herds and cattle, and some were entrusted with the communal herd when grazing land was not directly used by the neighbors, under the payment of a charge (Coppola, 2002a).

Only a small share of the agricultural land was freehold property. The feudal nobility, the merchant aristocracy, the nobles in the largest towns with a wealthy heritage, monasteries, ecclesiastical institutions, or hospitals and brotherhoods were few and had an insufficiently solid capital base. Aside from the chapter of the Cathedral of Trento (Nubola, 2002), other ecclesiastical entities actually survived on the rights of the *decima* and *quarta* (the tenth or the fourth part of production, respectively) rather than on the tax revenue from their landholdings (Varesco, 1981). Peasant individual ownership was common in the area but usually burdened with feudal or community duties. The increase of population in the 16th century led to an expansion of the aggregate demand on resources that was not counterbalanced by the availability of the resources. In fact, historians have noticed the expansion of farmlands in the period, particularly of land for cereal production, at the expense of the watershed, pasture, and forest areas (Coppola, 2002a, b).<sup>12</sup>

The organization of the land was typified by very large regional communal properties, the presence of few possessions of a certain size, and multiple small plots as strainers made payable to farmers. Closer to major urban centers, the importance of communal land decreased in relation to individual ownership; the closer to the high mountains, the greater the share of land relevant to the ever-growing communities in relation to the greater fragmentation of individual possession. Interestingly, at the feudal system level, while relieving the levy on agriculture (the *decima* and the *quarta*

---

<sup>12</sup> The sources used so far do not exhibit a clear picture of the land tenure system for the 16th and the 17th centuries. Some data are available at the community level on administration booklets and, later, on land registers. For earlier data, unfortunately, documentation is scarce.

type), the self-organization of production was no longer hampered. There was the moderate diffusion of free lands; however, the phenomenon was limited only to the middle and high mountains. The range of agricultural contracts did not increase substantially.

The forest economy remained substantially unchanged during the 17th century. On the demand side, the weakness of the shipbuilding sector was balanced by the need for wood for building in urban centers as well as the need for energy sources, especially for the development of local manufacturers, such as those creating silk. On the production side, the community-based production systems demonstrated enough robustness to ensure the continuity of a productive economic process in a satisfactory and rewarding way (Coppola, 2002a, b). The concessions of forest and the exploitation of common land were taxed by the prince-bishop and by the Tyrol (*steore* is the name of the Tyrolean tax) as an attempt to reduce the political power assumed by the communities (Bonazza, 2002). Varesco (1981) summarized land possessions in 1780 in Predazzo as differentiated by social groups. In this community, forests were entirely the common property of the community, and 50% of the tillable land was common property. Churches, fraternities, charitable entities, and wealthy people shared the properties of Predazzo (3.45% of the total).<sup>13</sup>

**2.2.4. Regional-scale shocks.** The following events have been considered to have had an impact on the political, economic, and social life of the communities and are the same as in Casari (2007): the outbreak of the Black Death in 1348, the Peasant War in 1525, the council of Trento from 1545 to 1563, and the crises of the mid-17th

---

<sup>13</sup> The *Urbario* (urban register) of 1387 provides no data about the land tenure system. The *Estimi* (register of estimation) of the 1400s does not offer a systematization. Not until the cadastral registers of 1780 (Archivio di Stato di Trento, 1780) is there data referring to pre-industrial times (Consiglio provinciale d'agricoltura del Tirolo, 1903).

century. The period from the crowning of Maria Theresa of Austria in 1740 until the arrival of Napoleon in 1796 also changed life in the communities significantly.

*The plague in 1348.* The plague outbreak of the 14th century, the Black Death, brought a decrease in demographic pressure on resources and the redefinition of both private and collective ownership. Trento had about 5,000 inhabitants in 1335 (Seneca, 1953). The chronicle by the priest John of Parma reported the dramatic figure of a mortality rate of five sixths of the total population in 1348. The same priest reported the effect of the plague on the production system: “There were few laborers, and the harvest remained in the fields because there were no gatherers” (Curzel, Palmato, & Varanini, 2001, p. 211, own translation). Effects on the labor market were remarkable: rural wages immediately rocketed upward, as well as the prices of such commodities as grain and wine. It took two centuries to reach the population level of early 1300. Riva and Rovereto, in the southern part of the region, reached the peak of their late-medieval demographic development in this period.

The first effect of the plague was a population decrease affecting densely inhabited centers, where the contagion was most devastating (Curzel et al., 2001). The effects followed with the employment of the surviving workforce in high-rent activities such as farming and agriculture, whose products could be easily exchanged on the market. This, in turn, resulted in a decrease in the price of meat, milk derivatives, and leather as well as the traditional migratory movements from remote communities to local centers. Pressure on the Alp (mainly located upstream) decreased, which resulted in the exploitation of forests at a sustainable level. The trade of timber on local markets through river floating led to an increase in the rents from commons. This evidence is in line with Haddock and Kiesling (2002, p. 2), who reported that the Black Death left nonhuman inputs virtually untouched; it therefore

profoundly altered relative factor values. Labor and human capital rapidly became scarce relative to complementary nonhuman factors, while the other factors grew increasingly abundant per capita.

*The Peasant War in 1525.* On 15 May 1525, the first peasant uprisings against fortresses and castles in Mezzocorona spread like a wildfire throughout the principality. An uprising had been fomented for a long time and was intended to paralyze the centers of noble power. The uprising of 1525 was in opposition to feudal power and was highly critical of the judicial system, administration of the region, and tax laws. Many of the abusive decisions issued between October 1525 and late winter of 1526 against the peasants were ameliorated after just over a year, and several punishments were converted into fines, allowing entry into the country of convicted peasants and the peaceful restoration of their possessions.

The process of normalization after the Peasant War included the granting of new rural charters to the communities, the reform of the Statute of Trento, and the achievement of agreements between the jurisdictions. The introduction of a double taxation (one to the Earl of Tyrol and one to the Principedom of Trent) and the increase of tax rates sparked the anger of large segments of the population in the early 15th century and was subsequently influenced by instances of religious renewal from Germany, which had a strong presence due to the progressive deterioration of living conditions of inhabitants in the countryside as well as the loss of ancient customs. This deterioration had, according to local historians, a unique cause: the continuous and uninterrupted request of fiscal contribution, linked to the rapid succession of warfare that increased the poverty of communities that were often overpopulated.<sup>14</sup>

---

<sup>14</sup> Archivio di Stato, Trento; Archivio del Principato Vescovile, Sezione latina, capsula 9, n. 54, cc. 74r-75v. The communities of Anaunia had provided many men to the battles of Grigioni, the struggles in Bassano, Tesino, Valsugana, Tenno e Calliano and the fights in Pontenegro (Verona), Brescia and Bergamo. Based on old privileges, the soldiers were not obliged to fight; in addition, the division of the

Many local churches, while wanting to remain faithful to the Church and the majesty of the emperor, could not serve two lords simultaneously. There was widespread impoverishment of the rural segments of society and the use of unfair and burdensome forms of credit by those who had liquidity (the nobles' monopoly). The farmers were no longer able to accumulate adequate reserves to address the downturn, and the free possessions often turned into emphyteusis.

*The Council of Trento (1545–1563).* The Council of Trento was formally opened on 13 December 1545 and ended on 4 December 1563. It was one of the most important events of the history of the Catholic Church, after the Council of Nicaea, which had occurred more than eight centuries earlier. The biggest problem was feeding the city because of an extreme food scarcity, especially of wheat, which made many cardinals afraid to go to the council for fear of becoming part of the famine while they were there. Trent and the surrounding area was subjected to great tension caused by the increasing economic demands facing an evident shortage of supply typified by a constant rise in prices, which came to be higher than those charged in Germany. Many non-participants to the council had no choice but to sell their horses (Jedin, 1981, p. 287; Mazzone, 2002).

*Crisis (1630–1650).* Some demographers saw in the 1630 plague outbreak a kind of watershed in the economic history of Italy. In fact, the plague, after several epidemics that had largely spared the city and removed the poorest, raged indiscriminately throughout society. The recovery was slow and difficult. In fact, in

---

spoils and of the profits obtained in Feltre and in Lombardy, and the arbitrary reductions of the military pay, were contested. The Diet of Bozen had reformed the Tyrolean Army, establishing the size and dividing the contingents so that the communities in Anaunia were requested to contribute with about 250 men: Levico with 15, Pergine 38, Stenico and the Giudicarie 80, Val di Fiemme 40, and Trento about 100. This imperial decision was not well received by the communities, so that also the fidelity toward the prince-bishop began wavering. During 1510 in the valley of the River Noce, there had been already three years of war, the outbreak of a plague in the summer of 1510, and a poor harvest. From 1511, there was a decline that would lead the jurisdictions of the principedom to a progressive insolvency (Andreolli, 1995; Chiarotti, 2002).

typical plagues “of the poor,” human casualties in the 16th century had been concentrated among unskilled workers of recent urbanization and the urban poor, easily replaceable with a migration from the countryside.<sup>15</sup> However, the 1630 plague affected many skilled craftsmen and employers, preventing the production system from working smoothly.

The entire Italian manufacturing economy was damaged, and it took many years to regenerate during, unfortunately, a crucial moment of competition with the Netherlands and northern Europe. The 17<sup>th</sup>-century crisis led to a decrease in population, thus relieving population pressure on resources. The crisis became harsh beyond expectations because of the advent of severe weather conditions that slowed the growth of the timber (Coppola, 2002a, p. 246), and the poor conditions led to a waste of timber that could not be worked and traded.

*Maria Theresa of Austria (1740–1796).* In the middle of the 18th century, the authority of the prince-bishop declined, with a limitation of his political power on the part of the Habsburgs, in particular, since the crowning of Maria Theresa in 1740. Inside the Prince Bishopric, the authority was limited by the increasing commercial importance of towns, of the feudal oligarchies, and of the system of self-government of Alpine communities. There was a necessity for political centralization to prevent political instability, and the centralization policy was one of the aims of the Habsburg Government. Reformation of tax collection was facilitated by the creation of the Land Register, which was dated 1780 (Archivio di Stato di Trento, 1780). It was a period of a renewal, also, of the liberal arts, which took the name of the “Roveretan Enlightenment.” In 1753, Maria Theresa of Austria reformed higher education, placing it in the Government’s hands. The education of legal scholars was profoundly

---

<sup>15</sup> Many pestilences occurred with periodical frequency, sometimes every 20–30 years in many communities in Trentino. See Varesco (1981) and the collection of catastrophic events written by Tovazzi (1986).

modified by giving a primary role to natural law. In practice, this rethinking of political and social thought led to a project civil code, which eventually came into force only in Galicia in 1797.

This constituted the first step toward a highly centralized State with a monopoly of law and enforcement, which became the law of the land under Napoleon. The concept of property rights appears to change radically toward the prominence of private property over other decentralized ownership regimes. Another reform that created tension between communities and the central state was the abolition in 1794 of *jus protomiseos*, which, according to the tradition, attributed a preemption right in the purchase of property to the family, the relatives, and the fellow citizens of the seller.

### **2.3. The *Carte Di Regola***

After the 13th century, communities began to draft sets of rules for the rational use of their resources and for a peaceful community life for members, rules that had been originally handed down orally from father to son. Rules contained in the *Carte* were enforced through representatives (*regolani*) appointed by the same members (*vicini*, “neighbors”) of the community.

The main institution of the community was the general assembly of heads of households, the *Regola*. From the year 1111, the prince-bishop of Trento began to grant the communities the privilege of managing autonomously some areas on his territories (*Patti Gebardini*—Gebardini covenants—for the Valley of Fiemme) in return for annual fees (Sartori Montecroce, 2002). The first *Carta* recorded is dated 1202, Civezzano (Giacomoni, 1991). After the 13th century, these concessions multiplied and took the form of rural charters and statutes for independent community governance, though still requiring confirmation by the bishop to be considered

enforceable before community members and third parties. The internal organization of rural communities was primitive but based on an innate organization of community principles of democracy. Their bylaws (*Carte*) were usually decided under a majority (or supermajority) rule by the *universitas*, or the *comunitas* (the totality) of the attendees at village assemblies, and often were the result of a long, face-to-face decisional process. The head of the community was normally called *Regolano*, *Sindaco*, or *Massaro* and was charged with taking care of the economic administration of the group. The *Saltaro* (from the Latin *saltus*, which means “wild forest”), instead, was the officer who ruled the use of the forest and the countryside.

A theoretic explanation for the emergence of formal institutions provides insights as to their persistence, aside from their resulting high costs. Each charter established a system of community bylaws directly contracted out and voted on in village assemblies (Casari, 2007). The adoption of a rural charter entailed two steps. First, the community gathered in an assembly, and only members of the community were allowed to attend and to cast a vote. In the assembly, the heads of households negotiated the content of the rules for access to the commons as well as the sanctions set forth against trespassers. The rules were written down in a formal contract by a notary in the presence of witnesses from other communities. Second, the charter had to be approved by the prince to be valid and enforceable. In the charters, it was possible to identify three basic types of rules: membership rules, governance rules, and sanctioning rules (Nequirito, 2002). From the detailed analysis of the rural charters, Casari and Lisciandra (2010) identified a three-level system of rights on common land attributable to individuals in terms of participation in community life, turning into different levels of access to collective resources and exploitation:



1. The *right of residence*, which includes the right to live in the community, and therefore to have a permanent residence, but not to use collective resources.
2. The *right of use*, consisting of the right to exploit the collective resources of the community.
3. The *membership right (vicinìa)*, which was full membership in the community, including all the benefits and obligations that the status entailed.

The first two rights are subsets of the third in the sense that the membership right was the broadest and included the right of use and the right of residence. In turn, the right of use included the right of residence and represented the minimum level of participation in community life. The phenomenon of the rural charter underwent significant quantitative and qualitative changes over time.

The textual analysis of rural charters exhibits a general lack of cohesiveness in the discipline of social and economic life of charter communities. A charter was actually a set of rules that community members established by writing them down whenever the need arose. When the regulation of an aspect of economic or social life was no longer adequate, new chapters were added, or communities proceeded to enact a complete reformulation of the charter.<sup>16</sup> For example, the introduction into the rural charter of Arco 1480 emphasized the need for a reform of the previous charter in 1295, as new circumstances had occurred that demanded change. The charter provided a rule stating the following:

... [T]he Community council and men from Arco in the diocese of Trento, who are here attending this assembly, consider that the ancient decrees, laws,

---

<sup>16</sup> These were subject to the same notary requirements and permissions as the drafts of the original documents. See Chapter 3 for details and clarifications on the history of the documents.

or *poste*, however named by the people, handed down by their ancestors, now begin to be worn with age, and that have emerged a large number of new facts, which require the support of new laws: indeed nature always hastens to produce new legal forms. (Riccadonna, 1990, p. 77, own translation)

After the 15th and the 16th centuries until their suppression, rural charters became increasingly structured and began to regulate in greater detail various aspects of community life, such as requirements for the optimal use of collective resources and, particularly, for the admission of strangers and the distribution of resources among community members.<sup>17</sup>

Each *Carta di Regola* needed the approval of the prince-bishop of Trento to be valid and enforceable at the village level (Nequirito, 2002; Varanini, 2004).

Nevertheless, when a charter was approved, the rural community was largely autonomous in its economic governance but had to abide by a series of feudal obligations imposed by the local lords governing the region, administering civil and criminal justice, and collecting taxes. This subjection was, in many cases, symbolized by the presence of a castle.<sup>18</sup> The aristocracy was also interested in forests and grazing lands, and unjust (and sometimes violent) expropriations began to become more frequent after the 1200s. However, the influence of the local lords was more related to non-commons. Factual evidence of the influence of the aristocracy on the economic governance of the community was noticeable in the following mentioned duties: repairing the castle and the adjacent properties of the lord, the collection of the *decima*, the right to nominate the *Regolano Maggiore* (the General Mayor) of the

---

<sup>17</sup> Thanks to Marco Casari and Maurizio Lisciandra for providing material for this paragraph.

<sup>18</sup> Personal communication with Annamaria Azzolini, Castello del Buonconsiglio, Trento (20 Feb. 2013). A map with the castles in the principedom from the 11th until the 18th century is available upon request.

village assembly, and the right to collect taxes. In exchange, the population of the communities frequently received privileges.<sup>19</sup>

After the arrival of Napoleon's armies in 1796, the *Carte Di Regola* system had a definitive decline in effect.<sup>20</sup> The emperor had proclaimed the annexation of Trentino to the Province of Tyrol in 1803; however, the prince-bishop had already left Trento in 1796. Although not formally abolished, the *Carte Di Regola* system suffered a strong attack that was prolonged in the years immediately after, culminating in its formal abolition with a circular letter of the emperor dated 5 January 1805. The official suppression of the charters occurred with the decree of the Emperor Maximilian Joseph dated 4 January 1807 and reported by the local historians Giampaolo Andreatta and Silvio Pace (1981):

We have asked for a circumstantiated relation on the constitution of the so-called "Regolanerie maggiori e minori," which, in some neighborhoods of the southern Tyrol form a sort of intermediate instance, and with the present [decree], we order that these abnormal institutions shall be totally and absolutely abolished, as incompatible with the new organization of the judicial districts as well as with any other regular administration of justice and police. In the aforementioned meeting, it shall be decided also in these Districts of Tyrol the Heads of the "Ville," and it shall be assigned to them the duties for

---

<sup>19</sup> Examples: Archivio Provinciale di Trento, Archivio dei conti Thun di castel Thun, documenti Cartacei (urbani e atti vari), 1372-1916, n.5, Urbario con stemma Thun, 1536-1549, regist cartaceo. Written in German; Privileges to the communities of Grigno and Tesino from the emperors and counts of Tyrol Leopold I and Joseph I of Absburg, confirming the rights granted in 1493: Archivio Comunale di Pieve Tesino, pergamene n. 217-218 (Laxenburg, 19 May 1700, and Vienna, 18 December 1709, sealed). See Nequirito (2002, pp. 141-142).

<sup>20</sup> For example, a common provision was the reduction of the number of village assemblies imposed by the Habsburgian Government in the community: Biblioteca comunale di Trento, BCT 1-2356, Carta di Regola di Breguzzo, 1795, volume cartaceo.

such Heads prescribed with the general order of March 1802. (p. 20, own translation)<sup>21</sup>

According to Casari, at that time, the vast majority of the communities had adopted a charter.

## 2.4. Conclusions

This chapter reviewed studies concerning common property in Alpine-like settings drawn from a vast array of literature on cases of commons. A brief description of the institutional history of the Trentino region followed. Key passages in the history of the region showed the transition from settlements into rural communities and the advent of the political economy of the village, the land tenure system, as well as critical historical events over the six centuries under the *Carte*. An overview of the rural charter system was summarized using secondary and primary historical sources.

Aside from the complexity of the economic, political, and legal dynamics that present historical events, it is noticeable that the region remained governed by the prince-bishop for eight centuries without interruption; this continuity, from the empirical standpoint, is important to delimit the area of observation of the *Carte Di Regola*. The village communities under analysis differed across many dimensions, so the adoption of a *Carta*, available to all, was adopted gradually by the majority. The discussion traced the transition from an informal to a formal institution for the management of the extensions of commons available to the communities. These private-order institutions were long enduring and had all the characteristics that Ostrom identified for robust institutions for the management of the commons in her lifetime of scholarly work. In addition to the other regional scale shocks observable

---

<sup>21</sup> The same passage is also commented and reported by the statistician Perini (1852) and the historian Nequirito (2004).

during the centuries of the case study, the arrival of Napoleon's armies in 1796 represented an abrupt exogenous institutional change in the region, particularly with the abolition of the *Carte Di Regola*, and the transition to a new centralized political regime based on the "rule of law." A civil code, centered on the preeminence of private ownership over the other existing arrangements based on common property, marked the decline of the self-governance of communities and eventually culminated with their forceful abolition in January 1807.

## Chapter 3: Data Sources and Documents

### 3.1. Introduction

The present chapter offers a discussion of the data sources and the documents used for the empirical analysis (Section 3.2). A description is given of the datasets used in Chapters 5–7 (Section 3.3). This chapter also provides some definitions employed in the description of the datasets and throughout the following chapters.

The dissertation uses micro-level data about institutions for property rights, resources, other historical and topographic information, population, and climate of 452 communities in the Italian Alps. The dataset offers the opportunity to seek support for the threshold hypothesis. The data cover the area of the current Province of Trento and span an extensive period, from 1200 to 1800.

When not specified otherwise, the community is the unit of observation. Communities are composed of one or more “villages” or subgroups of villages called “clusters” or simply “subgroups.” A village may include one or more “cadastral units” according to the 1897 Land Registers.

Over time, it has been observed that communities were governed under two alternative collective action regimes. With the adoption of a charter, a community entered the formal regime; that is, the situation of a community under a decentralized property rights allocation system, which follows the adoption of a written contract as a formal group “interaction technology.” In the analyses, this institution is termed “formal.” When the community did not have a charter, the “informal” regime is presumed. In this latter case, the community is considered to be ruled under a decentralized property rights allocation system based on customs (informal repeated interactions among actors in the commons). Communities that were ruled under the

formal regime and whose documents were lost are treated as ruled under an “informal” regime.

As a first approximation, community population was used as an estimate of the number of “potential” appropriators on the commons. Individuals in a generic community were divided in two classes: insiders and outsiders. The definition of potential appropriators encompasses both insiders and outsiders, as population estimates include both insiders and outsiders in the appropriators’ group. Insiders are the “legal” community members: individuals who belong to the “effective” appropriators’ group (*vicini*: literally, neighbors). Outsiders are non-members, and therefore, they are not legally entitled to access, use, or manage the common resources (*forestieri*: literally, foreigners).

When studying the formal regime, data were available to disentangle the figures and estimate the number of insiders involved in appropriation. The number of “effective” appropriators can be estimated only when a list of insiders is provided, and these lists are often available only when there is an assembly record in which it is possible to measure “participation.”

Participants in assemblies are categorized as attending or non-attending members or attending non-members. As in other studies considering the management of the commons in Italy (Alfani, 2011), the present analysis focuses on the group of insiders, the group composed of community members (*vicini*), this time disregarding the group of non-members, also called “outsiders” (*forestieri*). Participation in assemblies was a right granted only to insiders. Only active members could cast a vote both individually and on behalf of others if provided with a proxy power. Attendance was mandatory upon payment of a fine, and this mechanism was aimed at discouraging non-active membership by non-attendance as well as at ensuring

effective peer monitoring by the threat of social stigma. A residual category includes non-members; these were individuals who attended the assemblies and were not entitled to cast a vote.

### **3.2. Sources**

This subsection comprises a description of the sources obtained after the data collection. Table 3.1 summarizes the information available for property rights; content of the documents and organization of villages in communities; population, assemblies, and households; and land resources, climate, and topography. A separate subsection discusses the content of the sources for each entry.



Table 3.1.

*Sources of data*

Content of source	Code	Type of data	Reference
Property rights	S0101	List of communities in 1810	Andreatta & Pace, 1981
	S0102	List of Documents	Casari & Lisciandra, 2010
	S0103	Guide to Archives	Casetti
Content of Documents	S0201	Regulation data	Giacomoni, 1991; other sources
Organization	S0301	Organization of villages	Casari, 2007; Casari & Lisciandra, 2010
Population, Assemblies, Households	S0401	Italian population data	Bellettini, 1987
	S0402	Population data 1810	Andreatta & Pace, 1981
	S0403	Household size	Debiasi, 1953; Seneca, 1953; Chiocchetti, 1983; Garbellotti, 2006
	S0404	Attendants' data	Giacomoni, 1991; other sources
	S0405	Assembly data	Giacomoni, 1991; other sources
Land Resources, Climate and Topogr.	S0501	Land Register 1897	Casari & Lisciandra, 2010; Consiglio, 1904
	S0502	Precipitations	Casty et al., 2005
	S0503	Yearly Air Temperatures	Mangini et al., 2005
	S0504	Altitude	Google API
	S0505	Latitude and Longitude	Google API

*Note.* Data updated to research and data collection until 2 March 2013. Each source is named “S” followed by a two-digit code for the “content of the source” and another two digits for the “type of data.”

**3.2.1. Property rights.** This subsection illustrates the sources retrieved concerning property rights in each village. Two periods are distinguished in data collection: before and after the beginning of the 13th century.

*Before the 13th century.* Archival data are all but absent before 1200. Most documents, particularly ecclesiastical documentation, date from 1170 onwards: at that time, a re-organization of the Episcopal Bureau-Chancery occurred, and only from that time onwards do historians report reliable evidence concerning economic life of communities, settlements and agricultural practices, land rents, and commercial flows. Many documents are stored in private archives; for a reference.<sup>22</sup>

*During and after the 13th century.* Information about property rights arrangements in each village are drawn from a list of 879 documents produced by Marco Casari and Maurizio Lisciandra.<sup>23</sup> These data are retrieved from a variety of sources: the collection of rural charters in Giacomoni (1991), a guide of the local archives in the region (Casetti, 1961), published (mainly authored by local historians) and unpublished material (*Laurea* theses), online listings of the inventories and the archives in the region (Provincia Autonoma di Trento, 2011), and direct access to archives. The list of 879 documents concerns 275 villages that were organized into 254 communities. This dataset has been updated and enlarged during the research for this book, with further information on assembly attendance and with the coding of the content of the documents, as explained below.

Each community may have multiple entries, both when it adopts a charter for the first time (or a subsequent charter, when the first is not available) and when it adopts subsequent charters. This dataset records neither when a community joins a super community, nor when a single community separates from a super community.

---

<sup>22</sup> See Casetti (1961) and the online archives di Trento (Provincia Autonoma di Trento, 2011)

<sup>23</sup> The two authors are gratefully acknowledged for generously sharing this dataset. An earlier version of the dataset was used by Marco Casari in his 2007 article.

Each village can appear more than once, depending on how many documents it has issued over the observation period.

There are three classes of documents: complete charters, modifications of charters (also termed: amendments), and documents that are not charters. Complete charters are stand-alone documents that lay down the rules for governing the economic resources of a community; they can be a first adoption or later renewal of a previous charter. Some communities may have no charter, while others may have adopted up to seven complete charters in the period studied. Modifications are partial amendments to charters that occurred after the adoption of a complete charter that take the form of additions or appendices to the pre-existing document. Other documents regulate or contract the allocation of property rights on the commons but do not take the form of charters, although they may refer to charters. Examples are contracts of purchase of community membership and contracts for the division of common forest and pastures between two or more communities. In this study, the focus is on the first complete charters for two reasons: first, the first adoption of a rural charter starts a new interaction regime (formal institution); second, in complete charters, the collective action can be better observed.

The first *Carta di Regola* in the records dates back to 1202 (Civezzano); thus, the year 1200 is taken as the starting year in the analyses. From this year, communities could choose between either an entirely informal interaction pertaining to the commons or a formal mechanism where appropriation rules were created to govern the commons. Thus, communities without a charter are thought to have been under informal institutions.<sup>24</sup> As already commented, the cumulative trend of adoption presents an “S” shape with three sudden increases occurring in the middle of the

---

<sup>24</sup> A reconstruction for the time profile of charter adoption has been displayed in Figure S.1, Appendix C.

1300s, the beginning of the 1500s, and the beginning of the 1600s. One explanation for these sharp increases may be the effect of particular historical events at the regional level, which may have affected the propensity of the prince to grant such charters: the “Black Death” in 1348, the Peasant War of 1525, and the plague of 1628. Simply considering their diffusion, rural charters appear to have been an effective system for the decentralized management of the commons (Ostrom, 1990): when the system was declared unlawful and abolished by Napoleon in 1803, more than two-thirds of the communities in the region had adopted a charter (Casari, 2007).

**3.2.2. Content of documents.** The normative content (hereinafter: “content”) of the charters regulated the economic life of the community and represents a case of emergence of private-order governance regimes for the management of natural resources (Casari, 2007). Given that communities might include one or more villages, a community charter could deploy effects on multiple villages. The systematic reading of the text of the charters led to the construction of the “polity” dataset, which contains detailed information on the content of a sample of 260 documents. The present subsection offers a succinct description of the variables describing the content and the structure of the institutions.

A total of 8,994 bylaws articles representing the 260 documents reporting information on assemblies have been coded in the polity dataset.<sup>25</sup> Of the total, 580 articles (6.4%) belong to the “Unknown Content” category, as the length is known but

---

<sup>25</sup> The details on categories (coding rules, examples, and the actual coding) are described in a separate document, Appendix F. Although the four categories are aimed at the description of the village polity and are inspired to the famous dataset Polity IV (available at: [www.systemicpeace.org/polity/polity4.htm](http://www.systemicpeace.org/polity/polity4.htm)), the analysis of the body of regulation and the development of the codebook for this specific case has largely benefited by ongoing joint work with a research group on the regulation of institutions for collective action guided by Tine de Moor and based in Utrecht since the year 2010 (see: [www.collective-action.info/](http://www.collective-action.info/)). The accuracy of the codification has not yet been verified by other coders. The main difficulty is grounded in some typeset compilations of statutes only recently published (Giacomoni, 1991); most of the documents are written in ancient Italian, local dialects, and often in Latin. Therefore, inter-coder agreement statistics, like Krippendorff’s alpha, could not be computed.

not the actual content. Each numbered paragraph (article) has been assigned to one of the following categories (in parentheses: the number of coded articles for each category, the percentage of the total of 8,994):<sup>26</sup>

1. *Community Governance*
  - 1 a. *Governance* (1,404 articles, 15.7%)
  - 1 b. *Participation* (364 articles, 4.1%)
  - 1 c. *Constraints on Outsiders* (957 articles, 10.6%)

2. *Resource Management* (5,689 articles, 63.2%)

The first macro-category identifies the rules that the assembly decided to apply in governance of the community, and not those aimed directly at the management of the collective action on resources. Governance rules describe the requirements and the duration of assembly roles and define the system of checks-and-balances necessary to elect and make accountable (and, occasionally, even liable) those who were called to lead the institution for collective action in their capacity of community officers (Example 1, Appendix F). Participation rules described the requirements, the periodicity, and the modes of participation to legislative assemblies of community members. Another set of rules described the behavior of the community toward the outsiders (Examples 2, 3, 4, Appendix F). These rules are named “constraints on outsiders” (Example 5, Appendix F), because, generally, these rules imposed limitations to the action of outsiders, who were excluded from assembly participation. Therefore, this exclusion also entailed the impossibility of being an active part in the rule-making process.<sup>27</sup>

<sup>26</sup> As noted above, 580 articles (6.4%) belonging to the “Unknown content” category were omitted.

<sup>27</sup> Such limitations were normally welfare-detrimental to outsiders; for instance, limitations were imposed on the extension of village membership as a consequence of marriage with a village member, or limitations in the access and use of the commons as a consequence of inheritance rules when the offspring was born from a mixed marriage (marriage of an outsider and an insider), or the requirement of the payment of a lump sum to be admitted to the village membership or the use of the commons, or limitations in being counterparts of resource-trading with insiders.

The particular structure of the charters allowed separation of this set of rules from another set that focused directly on resource management. These rules defined the precise actions and precautions that had (or had not) to be undertaken by village members in order to coordinate in the access and use of natural resources, mainly the commons (forest and pasture; Example 6, Appendix F). The violation of each rule was normally backed by a monetary sanction (Casari, 2007), comprising at least the restoration of the damage and often a component to deter future damages. This latter component was highly variable and increased according to the action (i.e., grazing the cattle, cutting timber), the condition of the tortfeasor (i.e., village member, foreigner, etc.), and the timing of the offense (i.e., during the day or night, caused once or caused repeatedly). In this sense, sanctions were “graduated” (Ostrom, 1990; Ostrom, 2005a).

The rules were addressed to the community members, *vicini*, who comprised the group of the insiders. The requirements for being part of the insider group, as well as the procedures for being admitted to the insider group (membership rules), were carefully specified in the community bylaws. Such “contracts” were drafted and voted for by the representatives of the insider group itself: the heads of the families, who comprised the *Regola*, the legislative assembly of the community. The residual portion of the community population comprised of the *forestieri* (outsiders, or “non-members”), who normally were neither granted participation in the community governance nor access to or management of the commons (mainly pasture and forest) unless the regulation allowed them use or access rights by virtue of monetary payments (purchase of rights) or inheritance (Casari & Lisciandra, 2010). Though not necessarily a minority, outsiders were, therefore, passive subjects of the rules determined by the legislative assembly of the insiders; therefore, it is not surprising to

find rules aimed at imposing constraints on their actions and rights within the community (Example 5, Appendix F).

Although the bulk of the rural charters is represented by practical resource management rules (Example 6, Appendix F), the text of the rural charters describes in detail the governance of the community (Example 1, Appendix F) and the modes of participation in legislative assemblies. Together with the provision decided, it reports sometimes the minutes of the meeting: attendance was generally mandatory, and absence (Example 2, Appendix F) or non-cooperative behavior in assemblies (e.g., swearing, insulting or beating assembly participants, or simply carrying weapons during assemblies, as in Example 3, Appendix F) were subject to punishment.

At times, a description of the voting procedures was also specified in the documents (Example 4, Appendix F), and often were reported the assembly quorums and the modes for representing resident village members who were not able to participate for a just cause.<sup>28</sup>

**3.2.3. Organization of communities.** “Single-layered” communities are considered separate from “multi-layered” communities (Chapter 6). In order to be able to draw the distinction, information was collected from several sources about the first document ever issued from each community, the number of villages included in each community, and evidence of multi-village organization. The information described in this subsection is included in the “main” dataset.

***First documents.*** Data about the year of the first documentary evidence of villages have been collected from three sources, including the earliest document written in that village, mentioning a person coming from that village, or simply

---

<sup>28</sup> Codebook at Appendix F, section “Participation.”

quoting the village name.<sup>29</sup> First, the online lists of all the archives (Casetti, 1961) and the inventories in the Trentino region (Provincia Autonoma di Trento, 2011) were searched. The online sources quote archives and inventories and organize them in six categories: communal archives, parish archives, private archives, communal inventories, parish inventories, and private inventories. Second, the first evidences of local churches were sought, being considered a good indicator of stable settlements in the region (Curzel, 1999). It was also possible to reconstruct the first document available in every archive of the region using the archive inventories compiled by Casetti (1961). This latter source also contains notices from local historians and archivists concerning the documents of the single villages. Third, the name of the first notary from each community in notarial records was sought using the compilation of Father Remo Stenico (Stenico, 1999). The year of the first documentary evidence of a community is determined by the earliest documentary evidence of the villages that compound the community. Out of the total 452 units of observations (92.7% of the total), 419 years were obtained.

*Evidence of fission–fusion.* The data in documents allows also observing phenomena of fission and fusion among communities. Each entry refers to a community as composed by one or more cadastral units as described by the Land Register 1897 (Consiglio provinciale d’agricoltura pel Tirolo, 1903). Cadastral units were used as building blocks of single-village communities and multi-village communities using the information in the charters and from the other documents referring to the community. The patterns of aggregation and disaggregation of cadastral units were interpreted as indexes of fusion and fission, respectively. A first analysis of the data reveals that in the year 1350, there were 218 communities, 7 of

---

<sup>29</sup> A comprehensive guide to the archives of the area is offered in the online catalogues di Trento (Provincia Autonoma di Trento, 2011).



which were involved in fission, 19 in fusion; after 450 years, in 1800, within a total of 314 communities, 33 were involved fission, and only 5 in fusion.<sup>30</sup> A detailed study of each of these cases is the purpose of Chapter 6.

*Evidence of multi-village organizations.* In multi-layered communities, the village of origin of all the active members was reconstructed using data on “assembly” attendance. To obtain an estimate of the number of appropriators for this subsample, reference was made to the procedure used to estimate population, and then the average population of each village was calculated. However, many villages did not have a population estimate, and in the calculation of the population of the multi-layered community, three observations that had missing population values (10 estimates of cluster size) were disregarded. To estimate cluster size, the population estimate of the multi-layered community in the considered year was used and divided for the number of clusters. Therefore, every cluster in multi-layered communities, provisionally, has the same size. An improved estimate of each cluster’s size was based on effective attendance to assemblies: the whole community was considered represented when there were at least three active members from each village.

**3.2.4. Population, households, and assemblies.** Data concerning the size of groups is of utmost importance for this dissertation. Research in archives and in several other sources resulted in data on three levels of detail: population size, assembly size, and household size. These observations differ in nature: they are at times direct observations of data points scattered temporally or geographically or indirect observations of scattered data points or cross-sectional data retrieved from secondary sources. The present subsection offers a description of the procedures

---

<sup>30</sup> These preliminary analyses have been obtained using the “reduced panel” dataset, Section 3.3.2.

adopted to produce estimates that may be considered reliable for the analyses that will be carried out throughout the remaining chapters of the thesis.

Table 3.2.

*Population in Trentino (1200–1835)*

Year	Appr. Year	Original Est.	Estimate A	Estimate B	Source
	1200		47,594		Our estimate
	1250		88,674		Our estimate
1312	1312	83,280			Estimate based on Cole and Wolf (1999)
	1315		116,528		Our estimate
	1350		115,936	85,972	Our estimate
1427	1427	124,920			Estimate based on Cole and Wolf (1999)
	1450		115,196	90,721	Our estimate
	1550		159,671	139,860	Our estimate
1573-1615	1594	167,000			Franceschini (2009)
1650	1650	173,500			Estimate based on Cole and Wolf (1999)
	1650		163,411	147,340	Our estimate
1700	1700	200,000			Debiasi (1953)
1685-1723	1704	171,800			Franceschini (2009)
	1750		225,877	205,133	Our estimate
1754	1754	206,000			Cole and Wolf (1999)
1780	1780	180,000			Chiocchetti and Chiusole (1965)
	1800		265,805	241,245	Our estimate
1795-1810	1803	227,000			Franceschini (2009)
1835	1835	290,000			Cole and Wolf (1999)

**Population.** Population data at the village level was estimated from 1000 through 1800. This interval was chosen for two reasons. First, as mentioned above, written documents were extremely rare before the year 1000 (the earliest notice is dated 845). Second, this choice facilitates coverage of the entire period of the Bishopric of Trento (1027–1801). Village population was estimated, starting from the 1810 Napoleonic census of the population, at the village level (Andreatta & Pace, 1981) for 415 communities. The absence of some communities' population size for the year 1810 is because the census does not report a population for the villages; these communities do not appear in the statistics. A second source was a set of Italian population estimates at 50-year intervals from 1000 to 1800 (Bellettini, 1987). The first charter is dated 1202 (Civezzano); thus, the period 1200–1800 is used. The

populations of villages in the year 1810 were used to backward project population estimates for each community until the desired starting year of observation. This involved using a scaling factor that replicates the Italian population trend for 1000–1800 (Bellettini, 1987) with fixed gaps (smaller than  $k=50$ ) in each of the villages<sup>31</sup> by backward projection. The reference point was the Italian population for 1810 in Andreatta and Pace, arbitrarily approximated to 1800. The population size  $p$  of the community  $i$  at the year  $t = \{1200, \dots, 1800\}$  approximated at the nearest multiple of  $k=5$

is  $p_{it} = B_t \cdot p_{i1800}$ , and where  $B_t = \frac{P_{ITALIAN|t}}{P_{ITALIAN|1800}} = \{0,1\} \forall i \in I = \{1, \dots, 452\}$  is the scaling factor

based on the Italian population trend for 1000–1800, and  $I_t = \sum I_t \neq \emptyset$  is the number of communities in the main dataset in the year  $t$ . The trend was then calculated by backward projection with fixed gaps of  $k_t = 5$  between each observation. Population estimates were obtained for the surface of the Province of Trento covered by all the communities considered in this study existing in each  $t$  with a distance of  $k$  years,

$$P_{It} = \sum_{i=1}^{452} B_t \cdot p_{it}.$$

A limitation of this methodology is that the population estimates thereby generated could be considered a questionable approximation: it should not be possible to use national-level data at the community level or at the Trentino regional level. The limitations underlined in Casari (2007) are overcome in three ways:

1. erasing the observations in each year concerning communities that are not existent according to the used documents<sup>32</sup>;

---

<sup>31</sup> Figure 3.1, Appendix C.

<sup>32</sup> When a community is not existent, it is assumed that the resource endowments of the community (corresponding to the cadastral units compounding the surface of the community) are not used and that their absence in the dataset can be tolerable without loss of accuracy.

2. taking into account when a village joins a conglomerate of villages (fusion into a super community) or separates from a conglomerate (fission from a super community);
3. cross-checking the validity of this estimation method with population data from a variety of sources.

Several robustness checks of these estimates have been carried out. The first source is Trentino population estimates by other scholars: Cole and Wolf (1999), Ferrarese (2005), Franceschini (2009), and Chiocchetti and Chiusole (1965). The second is scattered village population data from various sources: Epiboli (1977), Varesco (1981), Goio (1978), Ciresa and Salvotti (1978), Piva (1981), Motta (1978), Curzel et al. (2001), Debiasi (1953), Seneca (1953), Ferrarese (2005), Franceschini (2009), Franceschini (2005), Chiocchetti (1983), Garbellotti (2006), Sparapani (1989), and Tardivo (2005).

The comparison with historical evidence returns results that confirm the internal validity of the method. The complete set of historical and historiographical sources comprises 486 observations of population size scattered in the whole Trentino region and throughout the period 1220–1849. These raw data were merged with population estimates produced for the same communities using a fuzzy matching algorithm that minimizes the Levenshtein distance (Levenshtein, 1966).<sup>33</sup> A perfect match was obtained ( $d=0$ ) for 257 observations; errors were manually cleaned, and 92 other observations having  $0 < d < 10$  were identified. For the total of 349 observations, a Spearman's rho of 0.8434 was obtained. For the perfect matches, an even higher correlation ( $\rho = 0.8713$ ) was obtained. This means that the case-by-case “correction”

---

<sup>33</sup> The Levenshtein distance between two strings is defined as the minimum number of edits needed to transform one string into the other, with the allowable edit operations being insertion, deletion, or substitution of a single character. The Levenshtein distance is widely implemented in algorithms for spellcheck in word processing software (Levenshtein, 1966).

of matched communities introduced errors in the sample but still at an acceptable level.

Population size estimates provide a general estimate of potential appropriators on the commons. Hence, population data at the village level for the period 1200–1800 are required. Cole and Wolf (1999), in their study on the Italian Alps, provide an indirect population estimate of 83,280 inhabitants in the region in 1312, of 124,920 in 1427, of 173,500 in 1650, of 206,000 in 1754, and 290,000 in 1835.<sup>34</sup> This means that the population increased 2.99 times between 1312 and 1800 (Table 3.2).

Population estimates (Estimate A) were first calculated for each community in the extended panel (Period: 1200–1800, Gap: 5 years. See: Section 3.3). Each community is observed since the year of the first document reporting its existence and when already included in a multi-layered community. According to Estimate A, the population increased by 2.28 times between 1315 and 1800, 2.99 times between 1250 and 1800, and 5.6 times between 1200 and 1800.

A more accurate estimate for the population of each community was obtained in the reduced panel in six selected years (Estimate B). The following were accurately adjusted case-by-case: fission–fusion of communities and multiple entries for the same community in the same year due to the simultaneous existence of communities both as single-layered entities and as part of multi-layered communities. The aggregate population at the regional level is estimated as 85,972 in 1350 and 241,245

---

<sup>34</sup> For their population estimates before 1754, Cole & Wolf (1999) referred to Wopfner (1954, p. 222–324), who reported that the Trentino represented the 34.7% of the total population of the Tyrol. For 1312, 1427, and 1650, Cole & Wolf (1999) reported only the total population of the Tyrol: to compute the respective estimates, the present author considered that the proportion between the population of the Trentino and the population of the Tyrol remained constant at 34.7%. For the 1835 estimate the source reported by Cole & Wolf (1999) is Fiebiger (1959, p. 15-16). The average of the populations in 1754 and 1835—248,000 inhabitants—is taken as a reference for the end period (1800).

in 1800.<sup>35</sup> According to Estimate B, the aggregate population in Trentino increased 2.81 times between 1350 and 1800 (Figure 3.1).

Some limitations in the production of population estimates have been unavoidable. First, they disregard the effect of internal migrations in the region. This minor criticism is offset by historical evidence. In their study of inheritance rules in the same area, Casari and Lisciandra (2010) point out that geographical mobility in the area is limited by the rules of transmission of common property. Second, population estimates include both insiders and outsiders on the commons: using population exhibits some limitations for the accurate study of the behavior of the insider group under the formal regime. This second point is overcome by the present arguments, which are based mainly on the determinants of group size studied under the formal regime.

***Household size.*** The issue of the household size was as been studied by local historical demographers, and since information is scarce and from scattered and heterogeneous sources, relying on an approximation is unavoidable. Estimates should take into account birth and death rates, migratory flows, catastrophic events, environmental conditions, and production system in a given historical period. The convention used by local historians (Bezzi, 1964) is to assume five people per family. This convention is also adopted in pastoral visits (mandatory since after the Council of Trento, 1564) and tax registers (reliable as from 1220), today stored in local archives (Debiasi, 1953; Garbellotti, 2006; Seneca, 1953). This approximation can be robustly applied to the whole group of attendants, as there was no requirement to own land individually in order to participate in the meetings. According to Seneca (1953), in 1333, every household (*fuoco*) paid 4 pounds of the imposed collection, in equal

---

<sup>35</sup> Close to the estimate by Cole and Wolf (1999); for details, see Section 3.3.

amounts everywhere in the Princedom of Trento. A household size of four individuals is inferred for present purposes. This lower size can be explained considering the demographic decrease during the second half of the c. 1300 (extremely cold winter). An increase in household size can be expected to have coincided with the demographic increase that occurred in 1258–1288. Debiasi (1953) asserts that using a multiplier of 5 provides a good approximation. The major limitation of this approximation is that it is fixed over time; thus, it does not control for fertility differentials across communities and over time.

There is further historical comfort for this approximation of five individuals per household. This number is a fixed index deduced by the ratios between the population of the communities analyzed by Debiasi (1953) and the number of the families of populated settlements where data were accurate (Data: a sample of communities located in Valle di Non (n=48) retrieved in two scrolls dated 1620 [A.S.T., Capsa IX, file 169, latin section; deck V, file 49, Atti Trentini] and 1633 [A.S.T., Capsa LXV, file 17 and Capsa IX, file 171, latin section], cited by Debiasi (1953)). These ratios range between 4.21 and 5.59. Debiasi excluded towns such as Lauregno, which has a higher index (6.90), as its population is of German origin: this population lived in strong familiar nuclei—indivisible farmsteads—and not in agglomerates of houses in communities. Other estimations of household size are used by historians for 1660. For example, Chiocchetti (1983) asserts, "... [T]he 75% of the families with living parents did not go over 5 components" (own translation). These estimations are based on a good number of French and English censuses, refereed by Chiocchetti, which provide a household size estimate of around 4.73 individuals per family (very close to 5). In the study by Garbellotti (2006) about poverty rates in Trento during 1717, the average household size was 3.12 for poor households and

4.74 for non-poor households. This considered, the convention of an average household size of five is adopted and fixed for the entire observation period (1200–1800). The scattered information has been included in the “documents” dataset.

Table 3.3.

*Assembly roles 1245–1801*

<b>Roles</b>	<b>No.</b>	<b>%</b>
Accountant	1	0.01%
Assistant Consul	4	0.05%
Assistant Head of the Community	12	0.15%
Assistant Officer	1	0.01%
Captain	2	0.03%
Community member	6,211	79.99%
Consul	116	1.49%
Counsellor	102	1.31%
Elected representative	103	1.33%
Head of the community	198	2.55%
Juror	217	2.79%
Knight	2	0.03%
Mayor	82	1.06%
Notary	135	1.74%
Officer	168	2.16%
Outsider	1	0.01%
Priest	1	0.01%
Representative	17	0.22%
Representative of the Emperor	3	0.04%
Secretary	5	0.06%
Witness	384	4.95%
<i>Total attendants</i>	<i>7,765</i>	<i>100.00%</i>

*Note.* Source: assemblies dataset.

**Assemblies.** As in other studies considering the management of the commons in Italy (Alfani, 2011), the present study focuses on the group of insiders (*vicini*), the group composed of community members. Another estimate, which can capture the size of interacting insiders on the commons, was derived. This estimate gives a number of appropriators on the commons authorized by the institution the insiders decided to create. Therefore, the population and insider estimates diverge, and the



second is obviously smaller. For the purpose of this study, there is no need to know the number of outsiders; thus, it is disregarded.

Assemblies were usually held in the square of the village. The sound of the village bell tower (*ad sonum campanae*) announced that the assembly was summoned. The day before, each participant would have been called to attendance with a door-to-door explicit convocation by a village officer. Often, the documents reported in their preamble a summary description of the assembly dynamics, and these preambles are the essential sources to understand the functioning of the institutions. The preamble of the documents often contains information concerning all the attendants: their name and surname, the name and the surname of their ancestors, their job in the village, their village of origin, and the role they had in the assembly. Assembly quorums were also reported.<sup>36</sup> Additionally, documents report the name and the surname of the notaries that wrote the charter and the witnesses (usually coming from other surrounding villages).

From the 879 documents, information was extracted concerning the attendance at village assemblies from 1249–1801. A subset of 243 documents contains a list of attendants, a small subset of 102 documents reports the quorum of the attendants, and 92 documents exhibit a complete list of attendance together with the quorum in fractional form (i.e., one half, three quarters, eight ninths, etc.). Only meetings with two attendants or more recorded were selected for the purposes of the present study.<sup>37</sup>

The individuals catalogued number 9,301 from 413 locations. Including relatives used in identifying a member, a catalog of 12,638 individuals comprises the “assemblies” dataset. The relevant information has been copied in the dataset of the documents: number of “active members,” number of “non-active members,” number

---

<sup>36</sup> Quorums measure the fraction of attendants qualified to cast a vote out of the total of qualified attendants.

<sup>37</sup> This information has been imported to the documents dataset.

of non-members, and number of villages represented in the assembly. It was eventually possible to construct a dataset on assemblies from the direct observation of the preambles to the original documents' sources. A selection relevant for this study is obtained by keeping only the assemblies with a complete list of attendance and focusing only on active attendance: (7,765 individuals). One issue in constructing the database was that there were individuals registered with their father's or grandfather's surname, or sometimes only a nickname: 5,698 (70.1%) individuals provided their surname, 2,027 (24.9%) provided their father's surname, 33 (0.5%) provided their grandfather's surname, and 367 (4.5%) provided a nickname. Individuals may accumulate more surnames, or just have a nickname, both, or nothing but their name. When the surname of the observed individual was not available, and the individual was cited to be the "son of" or the "nephew of," the surname of the closest relative was attributed. The sample covers the assignment and enforcement of property rights on land in 159 communities and instances of the assemblies from 1245–1801. Table 3.3 provides an illustration of how the individuals recorded in the dataset were distributed according to their role in the assembly.

The individuals represented in the table can be divided into two classes: those having voting rights (active if they cast a vote, non-active if they do not) and those without voting rights (non-members) in the process of deliberation of the community charter. The attendees without voting rights were the notary, the witnesses, and other non-attending village members.

Typically, the group of attendants was not huge: a smaller decision group faces a lower amount of transaction costs in collective action. The documents in some cases reported a quorum.<sup>38</sup> The number of villages represented in each assembly is

---

<sup>38</sup> Table 3.4, Appendix D.

also an interesting variable, reported for the sake of completeness, and is not to be confounded with the number of villages in the community. In fact, assembly attendants, including witnesses and notaries, may come from different villages that are not necessarily part of the organizational structure of the community.

**Participation.** For the purposes of the present study, “quorum” is defined as the percentage of active members in the community assembly required for the meeting to be validly constituted and to deliberate the collective decision. The sample size of assemblies where both the number of attendants and the historical raw quorum are available is 92. The sample size of communities with a list of active members but without mention of a quorum is 147. The total sample of communities having a list of attendance with two attendants or more is, therefore, 239. The main advantage of this selection is that it allows the analysis of the dynamics in assemblies using different data with higher detail at the group level (quorum and content of the decision-making) and at the individual level (personal information; social status; whether in favor or against the decision if attending, identification of non-attending, village of origin, occupation, and other information concerning familiar relationships of the individuals, whether attending or not). Additionally, such lists also report details about non-members having a particular role in the assembly, such as notaries and witnesses. The lists of attendance are usually placed at the beginning or at the end of the documents.<sup>39</sup>

**Appropriation.** An estimate of the number of insiders was inferred from evidence of community assemblies. The estimate produced is the number of people potentially participating in appropriation on the commons, and not only in collective choice during assemblies. The number of active members does not provide a real

---

<sup>39</sup> This information has been imported to the documents dataset.

figure about the number of people in the insider group (i.e., the group involved in appropriation). Appropriation involves the number of people in a family, while at a meeting there is only a member. Hence, the household size, considered as a unit for preference aggregation, is of interest for the study of appropriation. Estimates are built for the size of the group involved in appropriation on the commons, using the convention of five individuals per family to estimate household size. To estimate participation for the sample of documents reporting attending members but without a quorum, a pondered average of the 102 quorums found in the documents,  $q_p \approx 0.73$ , was used.<sup>40</sup>

It was assumed that there is no distinction between a constitutive quorum (the number of members required to consider the assembly valid) and a deliberative quorum (the number of attending members required to consider the decision valid). All the members were obliged to attend the assembly; therefore, it was not necessary to specify the compliance to a constitutive quorum. The notary could report in the document the share of attending individuals (e.g., “Two parts out of three of community members are attending this assembly”), or a phrasing referring exclusively to the decision (e.g., “The decision is taken by the two parts out of three of community members”). In the latter case, it is assumed that the notary reported the number of members collectively undertaking the decision out of the total number of community members entitled to cast a vote, specifying the non-active members and, in some cases, the nays.

An important point in the wording of the document concerns whether the quorums in the documents are empirical statements or legal statements (the requirement of a particular quorum for the validity of the meeting). This distinction is

---

<sup>40</sup> Table 5.6, Appendix D. This information has been imported to the documents dataset.

important if the aim is to estimate the total attendants (the 100%) using the registered quorum in the formula  $\frac{a}{q}$  (where  $a$  is the registered attendance, and  $q \in \{0,1\}$  is the recorded quorum). If the recorded quorum is an empirical statement, the total figure would be a real estimate of attendance. If the registered quorum reports simply the fulfillment of a legal requirement, it means that the attendance could also be 100% when only 75% is reported; therefore, the legal quorum is an underestimate of the real attendance, and the 100% is the maximum possible estimate (with a risk of overestimation). From the wording of the document, this distinction is often non-obvious.

The total number of the members called to the meeting is calculated by dividing the minimum attendance by the quorum: this is the maximum number of attendants (a perfect estimate if quorums are empirical statements, an overestimate if quorums are legal statements). The mean value between minimum and maximum was found and multiplied by the conventional household size (five members per family). In this way, a reasonable estimate was obtained for the number of individuals involved in appropriation through the 239 lists of attendance reported in the documents.<sup>41</sup>

**3.2.5. Land resources, climate, and topography.** An estimation of the land resource endowments of each village was obtained by aggregation or disaggregation of the cadastral units to fit the surface of the units of observation as per the *Carte* of each village according to the cataloguing method used in the volumes by Giacomoni (1991). The 1897 Land Register reported by the Consiglio provinciale d'agricoltura pel Tirolo (1903) contains a detailed description of the surface of each cadastral unit

---

<sup>41</sup> Table 3.5, Appendix D. This information has been imported to the documents dataset.

per type of resource (plow land, meadow, fruit garden, vineyard, grazing land, alp, forest, lake, pond, wasteland, and houses).

**Land resources.** The total sum of the resources of the 452 villages does not cover the whole surface of the current Province of Trento. Additionally, the total sum of the 452 observations in the dataset would lead to repetition of many units, as the raw dataset can consider the same village both as a single community and as part of a super community. Additional sources of information about resources are the land surveys compiled in 1780 during the age of Maria Theresa (di Stato di Trento, 1780). These data are the most ancient available on resource use, comprising precisely collected data about endowments, use, and rents available for the preindustrial era (Perini, 1852). Casari and Lisciandra (2010) collected data in cadastral records about resources in 31 villages governed by the *Carte Di Regola* in 1780: surfaces in hectares of forest, meadow, and grazing land have been considered as commons. All the other resources (i.e., fruit garden, plow land, and vineyard) have been considered as managed under private property. This dataset includes data about the total rent of the whole land, with resource-specific details.<sup>42</sup>

**Topography.** Topographical variables considered were latitude, longitude, altitude, and linear distances. Additional data about topography have been retrieved from the dataset used by Casari (2007). The Google™ Distance Matrix Service, the same implemented by Google Maps, was used to determine linear distances (in kilometers) of villages from Trento and from the closest town as well as geographical district (all the communities are attributed a categorical value ranging from 1–15, corresponding to the contemporary administrative zoning of the region).

---

<sup>42</sup> This dataset was not used in the present study.

*Climate.* Proxies were built for climate in each community in the period 1200–1800. The proxies are based on temperature, precipitation, and altitude data, which are factors influencing the productivity of the land (Mathieu & Furter, 2007; Thapa, 1995)<sup>43</sup> and (likely) affecting group size. Altitudes have been collected with the aid of Google™ Elevation API, the same implemented by Google™ Maps. As to air temperatures and precipitations, two studies about the climate in the Alps over the past two millennia were found (Casty, Wanner, Urg, Esper, & Ohm, 2005; Mangini, Spotl, & Verdes, 2005). Estimates of precipitation by the two sets of authors for the purpose of studying precipitation and temperature variability cannot be applied to these studies. The period covered by the data (1500–2000) is insufficient for our purposes, and the comparison of yearly average estimates on seasonal data from 1500–1658 and monthly data from 1658–2000 would lead to unreliable results. Thus, it was decided to rely on yearly temperature and altitude as proxies for climate, as the sources found for yearly temperatures cover the whole period 1200–1800 and were recorded at a location close to Trento. Moreover, yearly average temperatures can already capture productivity without recourse to an additional instrument. The study by Casty et al. (2005) contains data on temperature and precipitation on the European Alps since 1500 with the purpose of investigation of temperature and precipitation variability. The four datasets produced by the same authors were consulted: seasonal estimates (for the period 1500–1658) and monthly estimates (for 1658–2000) for both temperatures and precipitation.<sup>44</sup>

---

<sup>43</sup> The proxies are retrieved from the data storage: <http://www.ncdc.noaa.gov/paleo/data.html>.

<sup>44</sup> Some specifications from the Authors:

Eighty-seven early instrumental temperature and 146 precipitation time series from all over Europe in combination with 11 documentary records for temperature (precipitation), including estimates derived from narratives, annals, scientific writings, and monastery records are used as predictors for the gridded reconstruction of the greater Alpine area climate. The data detailed by Mitchell et al. (2004; CRU TS 2.0; [http://www.cru.uea.ac.uk/timm/grid/CRU TS 2 0.html](http://www.cru.uea.ac.uk/timm/grid/CRU%20TS%200.html)), comprising monthly global land surface grids of observed climate for the 1901–2000

The study by Mangini et al. (2005) contains the reconstruction of air temperature in the Central Alps during the past 2000 years from the chemical analysis of a stalagmite retrieved in the Central Alps in 1998 (47.0882N, 11.6715E, 120 km North of Trento, 46.24N/11.42E). The dataset is compounded of 540 average annual temperature reconstructions within a period from 90 BC to 1935 AD. Between each observation, there is a gap of 3–5 years. The gaps are approximated to the nearest multiple of five—this involves one observation every five years, as representative of the five-year period, having as its figure the end-period year (e.g., “1205” represents the period 1200–1205)—and the duplicates originated thereby removed, obtaining 121 temperature estimates from 1200 until 1800, without fear of significant errors. The temperatures reported in the study were not of ready use, and they required treatment. The stalagmite was, for particular climate conditions, inside a cave at 2347 meters above the sea level, while communities were at an elevation ranging from 73 to 1579 meters. A handbook of Alpine meteorology (Kappenberger & Kerkmann, 1997) was helpful in suggesting a solution to this issue in preparing estimates for each of the years covered in this study. An empirical rule of Alpine climate indicates average temperature decreases of 6.5 degrees Celsius with any increase of 1000 meters in elevation. “In average” represents an annual average of temperature by applying a decreasing factor of -6.5 degrees Celsius for every kilometer below the altitude of the stalagmite. This empirical rule does not take into account many other meteorological variables affecting climate, such as humidity, winds, or thermal inversion. Meteorologists (Kappenberger & Kerkmann, 1997) assert that the

---

period with half-degree resolution (60km × 60 km), serve as predictors. These data revise and extend the recently published version of New et al. (2000). We selected 199 grid points representing the greater Alpine area (43.25–48.25N and 4.25–16.25E), excluding non-Alpine parts in France (46.25–48.25N and 4.25–5.75E), the Po Plain, and Croatia (43.25–45.25N and 5.75–16.25E). Temperature and precipitation are reconstructed independently, i.e. they share no common predictors (Casty et al., 2005, p. 1857).



“6.5°C/km rule” is affected by variability, with errors limited to  $\pm 10^\circ\text{C}/\text{km}$  (except when elevation is proximate to sea level). Similar estimates were produced for the average yearly temperature of each village by taking the temperature in the Spannagel Cave as a proxy and applying the 6.5/1000 factor to the absolute value of the differential of elevation between the Spannagel Cave and the considered community, to be added to the temperature registered in Spannagel (2347 mts. a.s.l.) in the year considered; that is,  $\hat{T}_{c/t} = T_{s/t} + \frac{6.5 \cdot |e_s - e_c|}{1000}$ .  $T$  stands for air temperature in  $^\circ\text{C}$ ,  $c$  for community,  $s$  for Spannagel Cave,  $t$  for the year, and  $e$  for elevation (altitude in meters above sea level). When a community is composed of more villages, the average altitude of all the villages was used. In all temperature estimates in the present study, air temperature is referred to. This procedure, according to meteorologists, ensures the production of a reliable proxy for yearly temperatures for altitudes ranging from 750 to 1300 meters above the sea level. Using this method, the yearly average temperature was derived for each of the units of observation in every year between 1200 and 1800.

### 3.3. Datasets

This section offers a description of the datasets and of the samples used in Chapters 5, 6, and 8 based on the sources described above. A summary is provided in Table 3.6.

Table 3.6.

*Datasets*

Chapter	Datasets	Sources	Additional
5	<b>main, documents,</b> <i>redpanel, exppanel</i>	S0101, S0103, S0201, S0102, S0401, S0402, S0403, S0405, S0501.	<i>Simulation</i>
6	<b>main, documents,</b> <i>fissionfusion</i>	S0101, S0102, S0103, S0201, S0401, S0402.	
8	<b>main, documents, polity,</b> <i>assemblies, heterogeneity</i>	S0101, S0102, S0103, S0501, S0201, S0403, S0404, S0405.	<i>Simulation</i>
A1	<b>main, documents</b>	S0101, S0103, S0402, S0502, S0503, S0504.	<i>Video</i>

*Note.* Each intermediate dataset is named with the filename in **bold**. The dataset used for analyses is in *italics*. A dataset groups sources of different types, described by the code in Table 3.1.

These datasets extend those used in Casari (2007)<sup>45</sup> in addition to the updated archival data derived from research carried out by Casari and Lisciandra.<sup>46</sup> The new datasets include temperatures, precipitations, details on assembly participation, organization of villages, and the coding carried out on the content of the documents.

The table groups the sources in a unique “folder of datasets” for each chapter. Each “folder” contains several “intermediate” datasets described in the previous sections (documents, assemblies, polity) or a combination of multiple sources (main, see Subsection 3.3.1). The datasets marked in italics are the final ones on which analyses are eventually carried out. Additional datasets are derived from one variable of the others for simulation purposes: these ones are described together with the simulation in each chapter of reference. The following subsections provide details on these intermediate datasets, separately for each chapter.

**3.3.1. The main dataset.** The main dataset contains the basic information for all the communities and the villages analyzed in Chapters 5, 6 and 8. It works as a

<sup>45</sup> Thanks to Marco Casari for having shared the datasets used for the 2007 paper and Maurizio Lisciandra for providing the complete dataset with all the information on the documents.

<sup>46</sup> Last version: 4 September 2010.

“cross-section,” prepared based on the one used by Casari (2007). The resulting dataset contains information about the year of the first adoption of a charter in each village. The dataset also includes geographical data and land resources data for each community: latitude and longitude, altitude, and linear distances from relevant towns in the region where a market would take place. Data on the internal organization of communities are also included. In order to include data on resources, these data were merged with the Land Register dated 1897 using, again, a fuzzy matching algorithm with minimization of the Levenshtein distance. This procedure allowed the reconstruction of the surface of the 452 communities.<sup>47</sup>

**3.3.2. Datasets used in Chapter 5.** Starting from the main dataset, an expanded panel was generated,<sup>48</sup> and from this panel, a reduced panel was generated containing the data about institutions for property rights, resources, other historical and topographic information, population, and the temperature estimates. Although the word “panel” is used, the datasets are not technically panels but multiple cross-sections in which a one-year-observation represents the events that occurred in a community in a timeframe of more years. In the expanded panel, each community is observed from the year of the first document—that is, at most 121 times between 1200 and 1800—with a gap set at  $k=5$  years, representative of the five-year period denoted by the end-period year (e.g., 1205 represents the period 1200–1205). In the reduced panel, the gap is set arbitrarily at approximately  $k=100$  years. Therefore, in these datasets, year  $x$  represents the period ranging from year  $x$  to the year  $x+k$ . This methodology serves the purpose of capturing institutional and other changes of interest that occurred between two dates, and is normally employed in survival

---

<sup>47</sup> Data about land resources in communities separated by almost 80 years were compared: It was considered that this potential limitation has only a limited impact on the estimates considering the late industrial development of the Trentino region. The first industrialization occurred in this region between 1850 and 1910, and this period is not covered by the scope of this study.

<sup>48</sup> Used in Appendix B for the event history analysis model in Section B.2.

analysis (Allison, 1984; Jenkins, 2004). Being two time-sensitive datasets, it was possible to include time-varying information other than the institutional changes derived from the dataset of the documents: air temperature, population estimates, scattered population data from other sources, and control for time trend.

The reduced panel improves the accuracy of the population estimates. To capture changes in surface extension and fission–fusion phenomena, a smaller panel is built in which each community is observed once and controlled case-by-case in six selected years (six cross-sections, or a heavily unbalanced panel), and only if a document reporting the existence of the community has been found before each considered year. This panel contains 1,564 observations, of which 1,498 are communities with a population estimate. The communities considered are those available in the cross-section dataset in each of six selected years, which (with the exception of the year 1450) have already been noted in Section 2.2. The events considered were the following:

- 1350: after 1348, the Black Death
- 1450: before the publication of the Guttenberg Bible in 1453, which starts the diffusion of paper as a way to convey information
- 1550: after 1525, the Peasant War
- 1650: after 1630, a period of crisis during the second half of the 17th century, in conjunction with the Thirty Years' War and a pan-European plague
- 1750: after the year 1740, crowning of Maria Theresa, Empress of Austria
- 1800: the end period, when Napoleon invaded Italy and abolished the *Carte Di Regola* system

These dates have been chosen arbitrarily in order to consider group size in conditions after the occurrence of critical historical events affecting population (Black Death and the crisis of the second half of the 17th century) and the political scenario (as in the Peasant War, the crowning of Maria Theresa, and the end period), two factors that may have different impact on the propensity of the prince to grant the charters to communities. Additionally, the midpoint of each century is considered a representative point for the century. The gap between the clusters of observations is set at  $k=100$  years. Communities in 1250 were disregarded, because no relevant historical event occurred in that year. Communities were observed in 1800 and not 1850, because between 1750 and 1800, the phenomenon of the *Carte Di Regola* underwent changes and lost the characteristics of self-governance and decentralization from the central authority. A treatment dummy was generated, which separates in a given year communities that adopted a charter from those who did not. When the observed community belongs to a super community that adopted a charter, the effects of this adoption also are considered to affect the sub villages.<sup>49</sup>

In order to identify the threshold in the size of the group of appropriators on the commons, another source has been used. The goal was to obtain an estimate from a source different from population to account for the presence of outsiders in the community. While the community population proxies the number of all the individuals “tempted” to overuse the commons, an estimate of the group of insiders focuses on collective action in the commons of those that are involved in running the institution and is, in general, preferable. In order to obtain an estimate of the

---

<sup>49</sup> The district of Trento (which includes the villages of Trento, Gardolo, Montevaccino, Cognola, Valsorda, Mattarello, Ravina, Romagnano, and Sardagna) was removed from the dataset for three reasons: 1) Trento was not governed by a charter granted by the prince but a statute; 2) Trento was directly governed by the prince and was not self-governed by the citizens; 3) Due to its size and the land resource endowment, the connectedness to commercial routes, and the vivacity typical of a urban center, Trento cannot be considered a community.

appropriators' group size, the procedure described in Section 3.2.4 was used.

Analyses were eventually carried out on the sample of appropriators' group size estimates in 239 assemblies from 1245–1801 included in the documents dataset and originated from the assemblies dataset.

**3.3.3. Datasets used in Chapter 6.** The fission–fusion dataset uses population estimates based on the 1800 data extracted from main and produced using the procedure described above in Section 3.2. Data from documents are used to reconstruct institutional changes. The villages are observed during their institutional changes in the management of common resources as the population changes. Since one of the purposes of the chapter is to understand the internal organization of the multi-village communities and their institutional changes, the village was adopted as the observation unit, being the basic unit of the multi-village organization, instead of the community. The goal was to obtain a dataset that allows simultaneously reconstruct, describe, and explain the following:

1. the organization and governance structures of the multi-villages, clusters, and single villages;
2. the group behavior exhibited in multi-villages, clusters, and single villages in relation to changes in population size: individual adoption, fusion, and fission;
3. the assembly levels, and identify the largest grouping meeting face-to-face (when more levels are available, it is assumed that the higher levels are attended by representatives);
4. estimates at the village and cluster level, obtained from unpacking the multi-village population estimates (the size of groups involved in institutional changes).

A set of 21 multi-village organizations—representing, in total, 129 villages, and a control group of 76 stand-alone villages in the Italian Alps—were observed between the years 1267 and 1796. These cases were studied to provide empirical support and understand how the fission–fusion behavior is related to transaction costs, group size, and institutional change.

**3.3.4. Datasets used in Chapter 8.** Chapter 8 exploits societal<sup>50</sup> and resource<sup>51</sup> diversities exhibited by 159 self-governing communities that wrote and voted on community bylaws to manage their common resources in the Italian Alps during 1245–1801. The unit of observation is the community where assemblies took place. All the communities having a document reporting a list of attendance over the period 1200–1800 were selected from the documents dataset, regardless of the type of document (a complete *Carta di Regola* or modification thereof), and a sample of 260 observations included in the time interval 1245–1801 was obtained. Statistical analyses were conducted on the sample of 8,994 coded bylaw articles included in the polity database. Using the assembly data on attendance,<sup>52</sup> an insider group size was estimated: the assembly was participated in by all the heads of the families, and—using the assembly quorums—it was possible to obtain an estimate of the total number of individuals qualified to attend (the number of the families that ought to attend the assembly) and to multiply this number for the conventional average household size of five individuals defined above in Section 3.2. In addition, in the final “heterogeneity” dataset, community-level population estimates are computed in correspondence to each assembly (but are not employed in the analyses) using data from the Napoleonic Census 1810 reported in Andreatta and Pace (1981) and included

---

<sup>50</sup> Measured by “surname heterogeneity” and “number of villages within a community.” See Chapter 8.

<sup>51</sup> Owing to the highly variable conditions of altitude, temperature, and position, settlements were endowed with resources in differing proportions, with evidence of this heterogeneity reported in a chart that uses the 1897 Land Register data (published in 1903). See Figure 3.2, Appendix C.

<sup>52</sup> Table 3.4, Appendix D.

in the main dataset and the Italian Population trend in Bellettini (1987). The sample mean population size is rather low (530 individuals), and the high variation in population may be explained by countless factors. In addition, data concerning land resources, climate, and topography were imported from the main dataset.

### **3.4. Conclusion**

The present chapter had the primary goal of providing a description and a critical analysis of the historical sources retrieved in archives and in local scholarly production for the Trentino region in medieval and modern times. In Section 3.2, the sources have been divided into five classes: property rights; content of the documents; organization; population, households, and assemblies; and land resources, climate, and topography. An illustration of each class followed sequentially in each subsection, in which is also included a description of the methodologies adopted to produce proxies that have been gathered in four intermediate datasets: documents, assemblies, polity, and, eventually, main. In Section 3.3, it is shown how the interactions of these intermediate datasets have been employed to produce the final datasets used for statistical analyses in Chapters 5, 6, and 8. Conceptual distinctions relevant for a better understanding of the consistency of the analyses have been drawn; these will be beneficial for the reading of Chapters 5–8.



## Chapter 4: The Threshold Hypothesis

*For that which is common to the greatest number has the least care bestowed upon it.*

*Every one thinks chiefly of his own, hardly at all of the common interest; and only when he is himself concerned as an individual. For besides other considerations, everybody is more inclined to neglect the duty which he expects another to fulfill; as in families many attendants are often less useful than a few.—(Aristotle, Politics, Book II, Chapter III, 1261b; translated by Jowett, 1885)*

*The larger the group, the less it will be able to favor its common interests.—(Olson, 1965)*

### 4.1. Introduction

This chapter discusses the threshold hypothesis, a conjecture about the impact of group size in collective action. When a group increases in size beyond a given threshold, it generates an institutional change. This study focuses on institutions for the management of common resources. This chapter offers a review of key contributions in the literature, and illustrates the existence and the characteristics of tipping points in group size. The existence of a possible relationship between tipping points in group size and institutional change is put forward. This study takes into consideration two types of institutional change: first, the transition from an informal to formal institution; second, the fission and fusion of institutions.

The remaining part of the chapter is structured as follows. This section clarifies some fundamental distinctions that advance theoretical arguments concerning group size, the degree of the formality of institutions, and the role of cognitive limits. Section 4.2 discusses relevant issues in the standard economic modeling of the

commons; Section 4.3 illustrates advances in the modeling of common property rights; Section 4.4 clarifies the role of transaction costs for various types of institutions and organization; Section 4.5 reviews studies in rational choice theory and new institutional economics about the relation of group size and type of institutions; Section 4.6 introduces the reader to findings in behavioral sciences and anthropology about the importance of bounded cognition and bounded rationality in relation to group size threshold; Section 4.7 discusses contributions on fission and fusion strategies; Section 4.8 concludes with a formulation of the threshold hypothesis. Chapters 5 and 6 present empirical tests of the threshold hypothesis illustrated in the present chapter. Below the reader can find a review of scholarly contributions concerning conceptual distinctions relevant to the threshold hypothesis.

The framework described in Chapter 1 has put forward a number of important distinctions, the first being the existence of alternative governance regimes for the commons. In addition, Table 4.1 contains a list of alternative governance regimes for upland commons based on Casari (2007). This table synthesizes alternative arrangements relevant for the case study of the commons in the Italian Alps, and shows the main contributions reviewed in Casari's (2007) article as well as others of interest with reference to specific features of each regime. The governance regimes considered in the case study of this dissertation are the last two shown in the table.

Other conceptual distinctions drawn in this chapter and relevant for the formulation of the threshold hypothesis are, *inter alia*: (a) how the commons have been modeled; (b) the distinction between managing resource production and managing the group's collective action; (c) the distinction between economic and legal property rights; (d) the scholarly definition of common property and the conditions for the emergence of cooperation on the commons; (e) the difference

between informal and formal institutions and organization; and (f) a definition of benefit-driven institutional change.

The content of the present chapter distinguishes governance regimes along two dimensions: a distinction between economic and legal property rights drawn in Barzel (1997) and a distinction between informal and formal institutions inspired by North (1990), among others. Further clarifications of the institutional regimes come from a historical investigation into the origins of common property provided in Chapter 2.

Table 4.1.

*Alternative governance regimes for upland commons*

Denomination	Rights	Institution	Features	Literature
<i>Open Access</i>	None	None	<ul style="list-style-type: none"> <li>– Uncoordinated action on the commons</li> <li>– Likely risk of resource overexploitation;</li> </ul>	Gordon, 1954; Schaefer, 1956; Hardin, 1968.
<i>Private Property</i>	Legal	Formal (State)	<ul style="list-style-type: none"> <li>– Effective exclusion of others on each one's partition;</li> <li>– No resource overexploitation;</li> </ul>	Demsetz, 1967; McCloskey, 1972; Clark, 1998
<i>Communal Property with State Enforcement</i>	Legal	Formal (State)	<ul style="list-style-type: none"> <li>– Effective exclusion, as long it is regulated and enforced by the State;</li> <li>– Definition of a group of insiders, but not organized: they compete;</li> <li>– Absence of internal rules of organization;</li> <li>– Risk of resource overexploitation.</li> </ul>	Libecap, 1982; Ellickson, 1991; McCloskey, 1972; Clark, 1998; Ostrom, 1990.
<i>Communal Property with Informal Enforcement</i> (*)	Economic	Informal (Group)	<ul style="list-style-type: none"> <li>– Insiders lack internal structure of governance;</li> <li>– Users engaged in long-term repeated interaction and cooperate (Folk Theorem);</li> <li>– Users capable of monitoring other's harvesting actions, but still imperfect;</li> <li>– Uncertainty about extraction levels;</li> <li>– Possibility of trespassing reduces the efficiency.</li> <li>– <i>Ideal for small groups;</i></li> </ul>	Casari, 2007. Fudenberg and Maskin, 1986; Abreau et al., 1990; Aoki, 2005; Myerson, 1997. Clay, 1997; Greif, 2006; North, 1990.  Baland and Platteau, 1996. Casari, 2007; Ellickson 1991.
<i>Communal Property with Private-Order Governance</i> (*)	Legal	Formal (Group)	<ul style="list-style-type: none"> <li>– Insiders negotiate rules to manage the resource, and rules are approved by the higher political authority;</li> <li>– More enduring as users ensure that the game is played indefinitely in the future;</li> <li>– Superior information about resource appropriation and about users' behavior;</li> <li>– Effective enforcement towards insiders and outsiders: monetary sanctions;</li> <li>– <i>Ideal for large groups.</i></li> </ul>	Ostrom, 1990; Casari, 2007; Bromley, 1992;  Ostrom, 1990.  Casari, 2007.  Casari, 2007; Dixit, 2007; Haddock, 2003. Greif, 2006; Milgrom et al., 1990.

(\*) This chapter

## 4.2. The Commons

In the absence of property rights, the simultaneous access to a common resource by multiple uncoordinated users is likely to lead to resource depletion and to the erosion of the welfare attainable from extraction (tragedy of the commons). The tragedy of the commons is a problem of collective action that is inherent in two theoretical aspects. The first aspect is the propensity to deplete natural resources under an open-access regime, whether renewable or not. This problem concerns the production function of natural resources that are governed by precise “biological” laws, the study of which is an important aspect of resource management. The second aspect is represented by the sustainable strategies adopted by individuals for use of a natural resource. Contributions concerning the governance of the commons refer to either one or both of these aspects. This distinction is critical, as it allows the separate management of the mechanical aspects of resource production from other aspects related to managing the collective action of the group of users.

The textbook example of an open-access resource is the fishery (Clark, 1990). A large body of literature has been written about the governance and management of fisheries since the seminal work by Gordon (1954). Gordon explored the economic theory behind the exploitation of fisheries and elaborated upon one of the most widely used economic models of resource use in the literature: the Gordon–Schaefer model (Gordon, 1954; Schaefer, 1956). Indeed, the concepts that were modeled in the article had already been discussed by A. G. Huntsman in the article “Fishery Depletion” (Huntsman, 1944). A series of papers by Gordon preceded this seminal article concerned with the optimal harvest in fisheries. The problem of “overexploitation” was modeled as a problem of “optimal effort” to exert capture of the “optimal catch.”

Before economics and institutional analysis, fishery issues have long been in the remit of marine biology and resource scientists who have described the static and dynamic modeling of resource management, and from which the term “bioeconomics” arose (Clark, 1990; Stevenson, 1991). Libecap and Johnson (1982) wrote one of the most interesting contributions about the inefficiencies of government regulation of fisheries; the authors recognized that all models written started by assuming that property rights surrounding the stock were always absent, reproducing a situation of open access with homogeneous agents. Instead, contracts were possible by allocating fishing property rights among heterogeneous fishermen. The shrimp fishermen in Texas in the U.S. had to engage in very costly negotiations to allocate property rights by contracting without State support; the costliness of such contracting was primarily due to the contracts being highly incomplete, since the contractual parties were heterogeneous in terms of fishing skills. In contrast, Libecap and Johnson also described the reasons for the absence of incentives for the State to regulate the industry, which substantially remained under a situation of common property of the fishermen.

These models have been appropriately extended to understand the “biology” and the “economics” of resources that work as fisheries, such as forest and pasturelands. Fisheries, water basins, oil wells, forestry, and pasturelands have in common that they are “commons.” Two elements are represented in the definition of a commons. First, multiple users (or commoners) have economic rights over a defined natural renewable resource. Second, each user cannot prevent other co-users from extracting units from the same resource. Technically, the use of a common-pool resource is rival but non-excludable: users compete on extraction quantities, and cannot prevent others from extraction. The resource has boundaries defined by nature

(i.e., by orography), and users interact accordingly in sharing the use of the common resource. As in the case of fisheries, boundaries are uncertain and require human intervention (zoning). Establishing boundaries may be expensive from the negotiation standpoint. Some users may prefer to exploit their superior knowledge of the resource (e.g., where the best catch will move, where the best trees are, or where the best grass is) at the expense of other potential users, which can lead to social dilemmas similar to the tragedy of the commons (Hardin, 1968).

### **4.3. Common Property Rights**

Early economic modeling neglected the role of transaction costs in the allocation of property rights (Coase, 1960; Williamson, 1979), a gap filled by Libecap in his 1989 book, *Contracting for Property Rights*. In addition, earlier economic models of resource use relied on a set of very restrictive assumptions in addition to the zero-transaction cost framework, such as homogeneous agents and the absence of incentives to cooperate.

The neoclassical paradigm of economic science assumed that the behavior of firms is based on a well-defined underlying institutional setting working in perfect markets, which the writings of George Akerlof (1970) and Ronald Coase (1937, 1960) proved to be a flawed view of how markets work in practice. There is the need to draw attention to the notion of “property” that results from the writings of institutional economists after Coase; for example, that which emerged from Demsetz’s *Toward a Theory of Property Rights* (1967) and other writings in 1964 and 1968 by the same author on transaction costs.

Demsetz (1967) reported an interesting account of the emergence of property rights among the American Indians as a way “to internalize externalities when the gains of internalization become larger than the cost of internalization.” The author

explained that property rights institutions evolve toward an institutional arrangement that ensures the highest benefit from ownership. Communal ownership was included in the analysis, together with private ownership and state ownership. Demsetz defined communal ownership as “a right which can be exercised by all members of the community” (p. 354).

Further discussion in the literature made explicit the distinction between economic property rights and the legal protection that the state grants to the economic expectations of individuals from the use of goods through the institution of property, intended as “ownership.” This distinction is made clear by Barzel (1997), who explicitly writes about *economic* property rights and *legal* property rights.<sup>53</sup>

The term “property rights” carries two distinct meanings in the economic literature. One, developed primarily by Alchian (1965; 1987) and Cheung (1969), is essentially the ability to enjoy a piece of property. The other, much more prevalent and much older, is essentially what the state assigns to a person (Ellickson, 1991). In the present study, the first are denoted as “economic (property) rights,” and the second as “legal (property) rights.” Economic rights are the end (i.e., what people ultimately seek), whereas legal rights are the means to achieve the end.

“The economic property rights an individual has over a commodity (or an asset)” are considered the “individual’s ability, in expected terms, to consume the good (or the services of the asset) directly or to consume it indirectly through exchange” (Barzel, 1997, p. 3).

“Legal rights are the rights recognized and enforced, in part, by the government” (Barzel, 1997, p. 4).

---

<sup>53</sup> Voigt (2013a) adopted a similar distinction between *de facto* (informal) institutions and *de jure* (formal) institutions.



These definitions are fundamental for distinguishing “open access” from “joint ownership”; that is, distinguishing situations of joint ownership of a good from “crowding” of a resource upon which different types of legal rights may also insist.<sup>54</sup> For example, 100 hectares of forest may be under communal ownership of a village, because each villager has an expectation of extracting an undefined quantity of goods. In this sense, the villager has economic property rights on the forest insofar as he has interacted with the other villagers. This distinction was the reason for a conceptual confusion between open access and commons present also in Hardin’s (1968) article and discussed later in related literature (Banner, 2002; Ciriacy-Wantrup & Bishop, 1975; Fennel, 2011). Stevenson (1991) defined “common property” as follows:

Common property is a form of resource ownership with the following characteristics: 1) the resource unit has bounds that are well defined by physical, biological and social parameters; 2) there is a well delineated group of users, who are distinct from persons excluded from resource use; 3) multiple included users participate in resource extraction; 5) users share joint, non-exclusive entitlement to the in situ or fugitive resource prior to its capture or use; 6) users compete for the resource, and thereby impose negative externalities on one another; 7) a well-delineated group of right holders exists, which may or may not coincide with the group of users. (p. 40)

Non-cooperative harvesting of the forest defines a situation of open access, under which neither economic nor legal rights can be enforced, and this is exactly the situation that creates a social dilemma in a “crowded” resource. Cooperative solutions in the harvesting of the forest are properly identified as a commons. Users

---

<sup>54</sup> The literature also considers the case of “semicommons”: “In a semicommons, a resource is owned and used in common for one major purpose, but, with respect to some other major purpose, individual economic units—individuals, families, or firms—have property rights to separate pieces of the commons. Most property mixes elements of common and private ownership, but one or the other dominates” (Smith, 2000).

communicate and are able to bargain for property rights and reach Nash equilibria; economic rights thus exist and are enforceable (Ostrom, Gardner, & Walker, 1994).

Legal rights may also protect the legitimate expectations of benefits through the setting of clear rules of cooperation backed by sanctions.<sup>55</sup> In this sense, the choice of a property rights regime is not indifferent to collective action (Ostrom, 2003; Ostrom, 2009a; Ostrom & Hess, 2007; Schlager & Ostrom, 1991). The successful economic governance of the commons is obtained when the players bear the short-term fixed costs of creating legal institutions and is similar to an investment, because the future revenues from cooperation offset the costs sustained for setting up the formal institution.<sup>56</sup> The characteristics of these “bottom-up” institutions are described by Ostrom in her *Governing the Commons* (1990), which states under which conditions Olson’s “logic” (1965) and Hardin’s tragedy (1968) may fall short in explaining the institutional reality of “CPR systems”(CPR stands for “Common-Pool Resources”). Ostrom succeeded well, with plenty of global case studies. Other economists and social scientists became interested in the study of the commons, such as Platteau and Baland (1998); Nugent and Sanchez (1998); de Janvry, McCarthy, and

---

<sup>55</sup> Sanctioning rules are recognized as extremely important for sustaining cooperation: See the important contributions by Kandori (1992); Fehr and Gächter (2000, 2002); de Quervain et al. (2004); Henrich et al. (2006); Rockenbach and Milinski (2006); Herrmann et al. (2008); Gächter et al. (2008); Henrich et al. (2010); Boyd et al. (2010); Sigmund et al. (2010); and Gneezy and Rustichini (2000).

<sup>56</sup> The formal institutional solution is based on written “social contracts” and leads to a more efficient solution of the dilemma, provided that bargaining costs are internalized by the network in terms of a marginal increase in information costs that does not overcome the marginal benefits from production. Usually, the agreement concerns restrictions on quantity and quality of resources extractable, limitations on number of users, and additional governance rules concerning the punishment of defectors. Technically, the formal regime works by restraining the first collective action (direct appropriation) to another collective action situation based on group formal decision-making (e.g., through a system of assemblies). Casari underlines that there are informational advantages in adopting a formal allocation regime: First, a clearer definition of property rights—restrained to a well-defined group of users who commit to cooperate in the long run using the institution and bearing the costs of creation and maintenance; second, certainty in the punishment, which acts as a deterrent of property trespassing, makes the property violator internalize the cost of trespassing, and sustains cooperation (Fudenberg & Maskin, 1986). Additionally, the setting of a restriction on the quantity of units demanded raises the individual rents from the resource. Membership rules then define a densely connected network of members, allowing a high level of social capital among the members that lowers discount rates and ensures social cooperation under the predictions of the folk theorem in a formal institution for collective action. Information costs are lower within the member’s network, which can set rules for the extraction of the resource at the optimal level, subject to the regulation constraint.

Sadoulet (1998); Bromley (1991, 1998); Baland and Platteau (1996); Chakravarty-Kaul (1996); Field (1985); and Ostrom and Walker (1989). The scholarship by Ostrom engendered a new research field and led to the production of a prodigious body of literature (Ostrom et al., 1999) with such originality and importance for the social science literature that her receipt of the Nobel Prize in 2009 was no surprise to those familiar with her work.

#### 4.4. Type of Institutions and Organization

Two other important books were issued in the 1990s about the economics of institutions for property rights. The first is *Institutions, Institutional Change and Economic Performance* (North, 1990).<sup>57</sup> North defined institutions as “constraints that shape human interactions” (p. 1). North argued that institutions were meant to “reduce uncertainty by establishing a stable (but not necessarily efficient) structure to human interaction” (p. 6), and the author distinguished institutions from organizations as “... groups of individuals bound by some common purpose to achieve objectives.

Modeling organizations is analyzing governance structures, skills, and how learning by doing will determine the organization’s success over time” (p. 5). This definition is adopted by the present study to draw a distinction between formal and informal institutions, as illustrated in the framework (Figure 1.1). The fission–fusion behavior is related to an organizational choice of the group engaged in collective action to structure their institutional interactions. Informal institutions are called by North “informal constraints”:

In all societies from the most primitive to the most advanced, people impose constraints upon themselves to give a structure to their relations with others.

Under conditions of limited information and limited computational ability,

---

<sup>57</sup> North, one of the key authors in new institutional economics and Nobel Prize winner in 1993, was also the author of an interesting book on the economic history of the Western World used as a reference for the present study (North & Thomas, 1973; North & Weingast, 2006).

constraints reduce the costs of human interaction as opposed to a world of no institutions. (p. 36)

North continued by illustrating the conditions that make informal institutions self-enforcing and provided a definition of formal constraints:

The difference between informal and formal constraints is one of degree ...

Formal rules include political (and judicial) rules, economic rules, and contracts. The hierarchy of such rules, from constitutions, to statute and common laws, to specific bylaws, and finally to individual contracts defines constraints, from general rules to particular specifications. (p. 47)

Many criticisms have been brought against the notion of transaction costs (De Alessi, 1983; Williamson, 1979), at least as many as have been brought against the notion of institutions (Voigt, 2013a), and this distinction, as noted in a previous chapter, is not different from the point of view of collective action (Banner, 2002; Libecap, 2009; Libecap & Wiggins, 1984; Ostrom, 2003). The collection and dissemination of information is crucial to ensure the cohesiveness of the social group as well as to define clear roles and objectives expected in a group from each component. At the first level, economic property rights belong to the realm of informal institutions (direct appropriation of the commons), while legal property rights are established with a legal institution (appropriation of the commons mediated by the participation in an institution). In general, the assignment of property right is a relevant event in a group, as it changes the behavioral norms for the assignment of the benefits deriving from the use of the good (including the commons); thus, different institutional forms correspond to different technologies regarding assignment of these benefits. In their “production,” these institutions are distinguished on three levels:

different types of collective action, different institutional forms, and different property rights (economic or legal).

The debate on common property institutions is an old one (as shown in Chapter 2). In recent times, contributions have shed light on the economic reasons for the transition from common property to private property (a) during the Enclosures in England, (b) with an economic analysis of both the legal regimes, and (c) with a recognition that the common property (or semicommon property) institutions were widely used in Europe throughout the late medieval and modern period. The general findings of these studies validate that Demsetz (1967), as well as all the literature about transaction cost-based explanations about institutional change, was more than credible.

McCloskey (1972) wrote one of the first studies on the effect of the open-field system on the efficiency of agriculture in England. Sixteen years later, Clark (1998), in the same journal, published an empirical study that confirmed McCloskey's results on the economic profitability of enclosures *vis-a-vis* scattering in the open fields. The common lands in England survived until 1750, because "enclosure was generally unprofitable before 1750 when changing relative prices made private property rights marginally more efficient." Smith (2000) formalized the concept of semicommon property rights and underlined that members of a group may rely on customs or set formal laws to delineate common property rights on land:

Various rights to the commons, both waste and arable, were quite well defined. Supervision of these limitations did not originate with an overlord. Many common-field villages were not under the direction of a lord of the manor. Instead, it seems that much of the regulation was customary and that some of the customs made their way into increasingly formal legislation. The

customs (and later laws) were administered by local town gatherings and the courts leet and, later, the equity courts. For some purposes, such as fence inspection, special officials (reeves) were sometimes appointed by the village assembly. (p. 137)

In another article, Smith analyzed governance and exclusion as two different mechanisms to delineate property rights on land by citing the emergence of the “open-field” system in England as an example (Smith, 2002).

#### **4.5. Group Size and the Type of Institutions**

This section outlines the terms of the relationship between group size and type of institutions by reviewing key contributions in new institutional economics. Section 4.5.1 describes why informal and formal institution have different transaction costs; Section 4.5.2 contains a review of previous works, which aims at finding a theoretical link between transaction costs and the existence of a threshold group size potentially driving institutional change.

**4.5.1. The cost of institutions.** Efficient institutions are meant to minimize transaction costs by defining efficient rules to allocate property rights (Eggertsson, 1990; North, 1990; Williamson, 1979, 1981). Barzel (1997) remarked upon the close relatedness of the concept of property rights with those of transaction costs and defined transaction costs as the costs associated with the transfer, capture, and protection of rights. The choice of a formal institution may be related to increasing transaction costs within which group size may be an important factor.

Intuitively, when group size increases, transaction cost also increases. This theory is explored in subsequent chapters. Although intuitive, this connection has been overlooked by researchers. Some models include transaction costs when evaluating the evolution of property rights; however, the same models also show size

only in terms of extension of the surface and include the assumption that groups have the same size (Field, 1985, 1989). The theory is clarified if transaction costs defined in the commons are the costs incurred by individuals in collecting and disseminating information about others' behavior and the level of resource exploitation in the appropriation of goods.<sup>58</sup> This is compatible with the theory that transaction costs increase with the number of appropriators on land propounded by Cheung (1969) in a study about share tenancy. The collection and dissemination of information about economic rights and entitlements relies on social interactions in the use of and access to land resources (Smith, 2002).

Questions remain about the link between group size and the degree of formality of an institution and if group size is a determinant of the organization of collective action (and, therefore, of the degree of formality of an institution). Mancur Olson's *Logic of Collective Action* (1965) provided the primary impetus to tackle this issue:

... unless the number of individuals in a group is quite small, or unless there is coercion or some other special device to make individuals act in their common interest, rational self-interested individuals will not act to achieve their common or group interests. (p. 2)

Ostrom (1990) showed that rational, self-interested individuals cooperate to create self-enforcing institutions for collective action with which to achieve a common goal. Therefore, Olson's statement is not false—it is simply a partial definition. Olson's thesis sheds light on the characteristics of group behavior compatible with a transaction cost-based institutional change. Olson defined the

---

<sup>58</sup> This definition includes the costs to acquire information about the neighbors' entitlements and includes the costs of an enforcement system, interpreted as the costs of the procedure needed to determine the subjects entitled to ownership of a good and the scope of their rights and to make the party who trespassed or misused property rights internalize such costs (fine or penalty).

purpose of organizations and referred to unorganized groups as “a number of individuals with a common interest” (p. 5). He stated that not all groups are defined by an organization and that “most (though by no means all) of the action taken by or on behalf of groups of individuals is taken through organization...” (p. 5). For individual interests, unorganized action is more efficient: “There is obviously no purpose in having an organization when individual, unorganized action can serve the interest of the individual as well as or better than an organization” (p. 7).

Olson (1990) does not exclude the notion that unorganized individuals may coordinate their individual actions to attain a common goal. To Olson, therefore, what is defined herein as an informal institution is an “unorganized group” (i.e., a number of individuals acting in their own interests without creating an entity that is expected to further the common interests of the group members, similar to labor unions). Formal institutions are “organizations” in Olson’s language. It is precisely within the realm of organizations that Olson’s arguments are applied with regard to small and large groups wanting a collective good. Individuals face different cost functions; thus, obtaining a collective good entails total costs that are an increasing function of the quantity of the good. Olson contended:

Sometimes a group must set up a formal organization before it can obtain a collective good, and the cost of establishing an organization entails that the first unit of a collective good obtained will be relatively expensive. And even when no organization or coordination is required, the lumpiness or other technical characteristics of the public goods themselves will ensure that the first unit of a collective good will be disproportionately expensive. (p. 22)

The distinction between formal and informal institutions, in Olson’s discussion (1990), is discreet. Olson asserted that individual gains are proportionate to



the size of the group, so that the larger the group, the lower the share of profits the individual will receive from the expenditure of participation in the collective enterprise. The non-technical conclusion of the Olsonian argument on small groups is that “the larger the group the farther it will fall short of providing an optimal amount of collective good” (p. 35), an argument that was challenged by Ostrom (1990).

The advantages of a small group include that individual contributions (or non-contributions) are noticed by others; according to Olson (1990), this is an obvious outcome of the number of individuals in the group. This theory seems to create a problem when the members’ contributions are not observable due to excessive group size. Group size may increase, but the costs of observing each individual’s contribution increases. This problem leads to the decision between an informal institution and a formal institution, summarized in the following eight Olsonian statements that summarize the economics of a transition from informal to formal institutions as determined by group size. The transition would be based on what Olson calls “costs of organization,” distinguished from the costs of contributing to the participation to the collective action, which are referred to in this dissertation as the transaction costs needed for the group to create and operate a formal institution.

Olson’s words were the following:

1. The smallest type of group ... may get along without any group agreement or organization.
2. A group agreement might be set up to spread the costs more widely or to step up the level of provision of the collective good...
3. In any group larger than this, on the other hand, no collective good can be obtained without some group agreement, coordination, or organization...
4. The larger a group is, the more agreement and organization it will need...

5. It may not be necessary the entire group be organized, since some subset of the whole group may be able to provide the collective good...
6. In short, costs of organization are an increasing function of the number of individuals in the group. (Though the more members in the group, the greater the total costs of organization, the costs of organization per person need not to rise, for there are surely economies of scale in organization)...
7. additional costs must be incurred to obtain an agreement about how the burden will be shared and to coordinate or organize the effort to obtain the collective good. These are costs of communication among group members, the costs of any bargaining among them, and the costs of creating, staffing, and maintaining any formal group organization...
8. there are significant initial or minimal costs of organization for each group. The greater the number in the group, the greater these minimal costs will be (Olson, 1965, p. 46).

These statements from Olson define his theory, on theoretical grounds—in the first statement that informal institutions are more suited to small groups, in the second and third statements that groups invest resources to set up a formal institution, and in the fourth statement that larger groups require higher formality (further discussed in Chapter 8 of this dissertation). Olson posits in the fifth statement that large groups may be organizations of sub-groups (further discussed in Chapter 6 of this dissertation) and in the sixth and seventh statements that individual transaction costs in appropriation normally increase with group size and that formal institutions limit these costs by adding a fixed initial cost of the formal organization that decreases per person as group size increases (economies of scale in organization). Olson concludes

in the eighth statement that this cost is higher when the group size is large as opposed to when it is small.

**4.5.2. Does a threshold in group size exist?** The final (eighth) statement raises a question about the possibility that there is a threshold size for a group when it metamorphoses from an informal to a formal institution. What may possibly determine this threshold, if existent? Olson (1965) does not discuss the issue explicitly; however, the existence of a threshold does not contradict his arguments, and neither does it contradict the other contributions in the new institutional economics. It has simply not been considered; nevertheless, this threshold may have important consequences for the decisions about how to structure efficient institutions.

Researchers after Olson (1965) tackled the issue of group size and identified a “paradox” concerning the mechanisms and the determinants of the voluntary provision of public goods. Theoretical, empirical, and experimental studies have tested or challenged, at different levels, (a) the Olsonian proposition that a “large group will fail,” (b) how large or small groups may or may not contribute to the provision, (c) whether large groups or small groups are successful, and (d) whether or not size is relevant (Agrawal & Goyal, 2001; Bandiera, Barankay, & Rasul, 2005; Chamberlin, 1974; Esteban & Ray, 2001; Oliver & Marwell, 1988). Ostrom defined the role of group size, together with group heterogeneity, as a puzzle in collective action (Ostrom, 2005a; Ostrom, 2009b; Poteete & Ostrom, 2004). These findings, although important, do not provide an answer to the research question of this dissertation (i.e., is there a group size threshold in the formalization of collective action?).

#### 4.6. Group Size and Cognitive Limits

While there is agreement in that different institutional forms have different costs, and that transaction costs increase with group size, no explicit prediction on a threshold group size emerged from the analysis of the literature. This section expands the analysis by considering the role of limited cognition and its relationship with group size. The bounded rationality assumption is discussed in paragraphs 4.6.1, and the argument is grounded on existing contributions in new institutional economics (North, 1990; Ostrom, 1990); Section 4.6.2 describes the relationship between bounded rationality (Williamson, 1986; Colinsk, 1996) and cognitive limits and suggests a proof *a contrario* for the existence of a threshold group size; section 4.6.3 offers a discussion of potential group size threshold values researched by anthropologist and behavioral scientists (Dunbar, 1993a, 1993b).

**4.6.1. The bounded rationality assumption.** The link between group size and the evolution of institutions was also inspired by North (1990). Interestingly, North provided the link with limited cognition, based on biological functioning of the brain, as influencing human transactions as a source of costs and potential institutional inefficiencies. In the following passage, he considered the origins of informal institutions:

Where do informal constraints come from? They come from socially transmitted information and are a part of the heritage that we call culture. The way the mind processes information depends upon the brain's ability to learn and be programmed with one or more elaborately structured natural languages that can code for perceptual, attitudinal and moral (behavioral) as well as factual information.(Johansson, 1988, p. 176)" (p. 37).

In addition, Ostrom (1990) assumed that individuals interacting on the commons have bounded rationality:

As an institutionalist studying empirical phenomena, I presume that individuals try to solve problems as effectively as they can. That assumption imposes a discipline on me. Instead of presuming that some individuals are incompetent, evil, or irrational, and others are omniscient, I presume that individuals have very similar limited capabilities to reason and figure out the structure of complex environments. (p. 25)

Thus, a theory of institutional change based on the idea of the existence of a critical group size threshold needs bounded rationality to be embedded by necessity as an assumption.

**4.6.2. Bounded rationality and cognitive limits.** Defining what is “bounded” in bounded rationality is necessary to identify a threshold and, thus, to enable empirical support in favor of the conjecture. Conlisk (1996) reviewed the available evidence on bounds of rationality. He divided the literature in two groups: studies (mainly in economic psychology) providing direct evidence from rationality tests on single individuals and studies providing indirect evidence of economic-bounded rationality jointly with other hypotheses. The first type of studies show that people often:

...display intransitivity; misunderstand statistical independence; mistake random data for patterned data and vice versa; fail to appreciate [the] law of large number effects; fail to recognize statistical dominance; make errors in updating probabilities on the basis of new information; understate the significance of given sample sizes; fail to understand covariation for even the simplest 2 X 2 contingency tables; make false inferences about causality;

ignore relevant information; use irrelevant information (as in sunk cost fallacies); exaggerate the importance of vivid over pallid evidence; exaggerate the importance of fallible predictors; exaggerate the ex-ante probability of a random event which has already occurred; display overconfidence in judgment relative to evidence; exaggerate confirming over disconfirming evidence relative to initial beliefs; give answers that are highly sensitive to logically irrelevant changes in questions; do redundant and ambiguous tests to confirm a hypothesis at the expense of decisive tests to disconfirm; make frequent errors in deductive reasoning tasks such as syllogisms; place higher value on an opportunity if an experimenter rigs it to be the “status quo” opportunity; fail to discount the future consistently; fail to adjust repeated choices to accommodate intertemporal connections; and more. (p. 670)

Although these studies confirm the existence of bounds of reason, limits related to group size seem not to belong to this family of bounded rationality. The second type of study assumes unbounded rationality, but failed predictions; thus, the author sought a proof *a contrario*, admitting that any explanation coming from this type of evidence would be confounded. These studies concern consumer behavior, the formation of rational expectations, decision experiments, and experiments on common value auctions. Economic modeling of bounded rationality refers explicitly to transaction costs in firms, organizations, and institutions. A link is also provided by Williamson (1986): “Economizing on transaction costs essentially reduces to economizing on bounded rationality...” (p. 110). An alternative explanation is provided by a family of economic models that Conlisk (1996) termed “population distribution models”:

A common type of model in which a population of individuals distributes over categories of some sort, making adaptive transitions among the categories as time passes. Transitions are governed by imitation, fitness-sensitive reproduction, or other mechanisms... Although most of these models view behavior as boundedly rational, some treat agents as perfectly rational but imperfectly informed.<sup>59</sup> ...Among the interactions considered are imitation, word-of-mouth communication, fads and fashions, bandwagons, threshold effects, herding, increasing returns, lock-ins, and informational cascades. (p. 680)

Thus, the factors explaining a transition from informal to formal are based on the assumption of bounded rationality and, under the hypothesis of a critical group size threshold, may be confined to two factors:

1. Dividing the population of  $N$  communities in two groups, informal and formal institutions, the transition of one community is more likely depending on the number of communities already having transitioned.
2. Considering each community singularly, there is a group size threshold determined by an existing link between transaction costs, bounded rationality, and capacity to acquire information.

The first explanation does not exclude the first and is more related to a well-established body of literature in sociology concerning “critical mass” and threshold models based on computer simulations and modeling rather than on direct observation (Granovetter, 1978; Macy, 1991; Oliver, 1993; Oliver & Marwell, 1988). If this explanation holds true, in the present study, the process of institutional change would be determined by the number of communities that already transitioned to a *Carta* and

---

<sup>59</sup> See Bikhchandani, Hirshleifer, and Welch (1992, 1998).

would manifest more as a diffusion process. However, Casari (2007) already tested whether the adoption of a *Carta* depends on the number of neighbors already having a charter and found no statistical evidence to support it. In addition, the author of the present study performed analyses that confirmed that the process of institutional change (that is, the transition to a *Carta*) seems not to follow from a “contagion” arising from neighboring communities. The empirical evidence from Casari’s and the present studies do not support this explanation.<sup>60</sup>

The second explanation is compatible with the claims in the previous subsection that (a) agents face increasing transaction costs, (b) these costs depend on each individual’s capacity to acquire information, and (c) these capacities depend on limits present in the processing and storage of information in the individual’s memory. The consequence is that these limits should be expected to remain constant as group size increases, and they may be associated with transaction costs; however, their origin is in the individual’s cognitive limits.<sup>61</sup> Thus, the transition to a formal institution may be related to the existence of a group size threshold related to cognitive limits or, more precisely, to memory constraints.<sup>62</sup> To make this claim testable, it is necessary to determine whether the memory constraints that determine the threshold are individual or whether they are general in the human species. The next subsection provides support from the literature as to why the latter is the case.

---

<sup>60</sup> A video displaying the geographical pattern of appearance of each community and the adoption of the first *Carta* has been prepared and is available upon request. The assistance of Delia Mocanu in preparing this animation during the course on network science at Northeastern University, Boston (MA), is gratefully acknowledged. The observation of the timing of adoption for the communities that adopted the first charter (Figure B.1), the geographical distribution of communities, and their population size displays no clear-cut visual pattern (Video on “Charter Diffusion”: firstcharter1.wmv). Hence on this point two conclusions are advanced:

- (1) The adoption pattern is not dependent on geographical contagion;
- (2) Adoption seems more related to the large size of villages.

<sup>61</sup> The consequences of this threshold on individual behavior may be that the capacity of being “perfectly informed” is affected, and yet the individual may also act irrationally. However, here, the interest is on the consequences on the institutional form of these limits.

<sup>62</sup> For a more recent model of bounded rationality based on memory constraints, see Mullainathan (2002).



**4.6.3. Estimates of the threshold.** An increasing number of empirical studies in evolutionary anthropology and behavioral sciences link group size to features of the human brain and, in particular, to the existence of a memory storage limit and the consequent capacity to manage a limited amount of information (Cowan, 2000; Halford, Baker, McCredden, Bain, & McCredden, 2005; Miller, 1955) or to the capacity to keep track and socialize with a variable, yet limited, number of acquaintances (Dunbar, 1993a, 1993b). The main finding is that there exists a threshold number of interpersonal contacts that an individual can manage. One consequence of this finding for the present study is that, in collective action of unstructured groups, this threshold value has an “upper bound” to achieve a successful collective action.

Dunbar (1993a, 1993b) indicated that this cognitive limit is proportional to the volume of neocortex, a part of the human brain that developed late in human evolution. The latest stages of the evolution of the human brain, and, in particular, of the neocortex can explain the adoption of language to communicate and set the basis of human society as known today (Dunbar, 1993a, 1993b). Group size co-evolved with language and the neocortex in human history. This assertion was defined by Dunbar (1998, 2003) as a social brain hypothesis. When the threshold value is overcome and the group gets larger, cooperation becomes difficult in unstructured groups; beyond a certain group size, individuals do not keep memory of acquaintances and of their reputations in terms of cooperation (Axelrod, 1984; Cox, Slockin, & Steele, 1999).

Dunbar (1993b) illustrated the results of his statistical analyses on a sample of  $N=36$  non-human primate genera:

The estimating equation is a best-fit reduced major axis regression between neocortex ratio and mean group size:

$$\log(N) = 0.093 + 3.389 \log(C_r) \quad (4.1)$$

( $R^2=0.764$ ;  $t_{34}=10.35$ ;  $p<0.01$ ), where  $N$  is the mean group size and  $C_r$  is the ratio of neocortical volume to the volume of the rest of the brain (Dunbar, 1993a, p. 682).

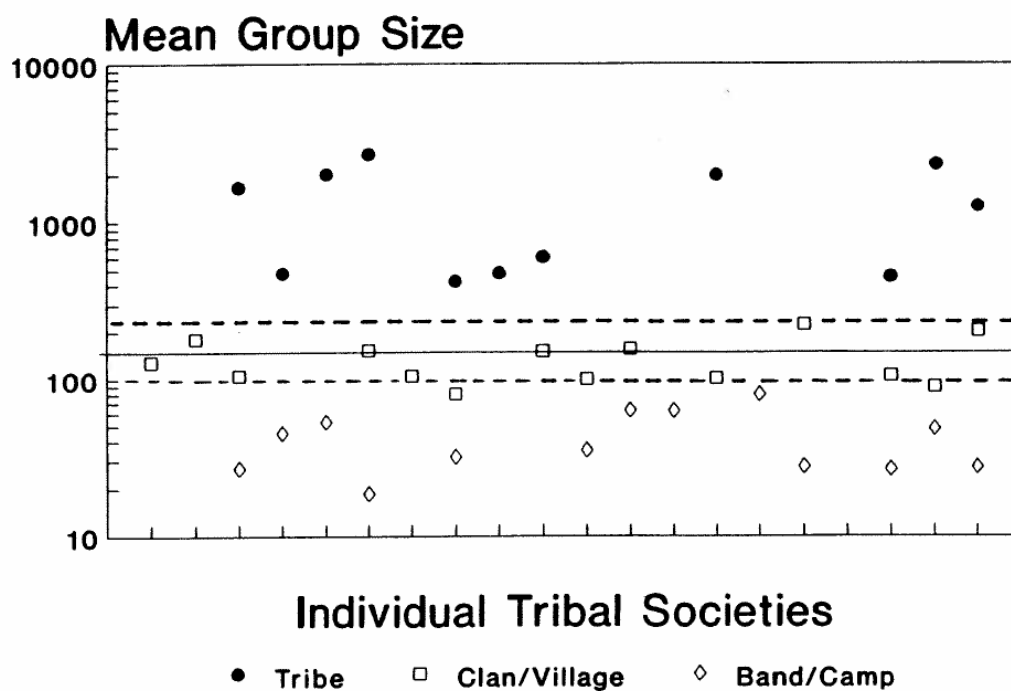
When Dunbar applied this estimating equation to the neocortex ratio of the human brain, he obtained a prediction of 147.8; the range is moderately wide (100.2–231.1 individuals, 95% confidence limit). Other estimates based on different neocortical indexes give predictions of 107.6, 189.1, and 248.6, all within 95% confidence limits.

The same author compared the resulting estimate with scattered results on many human societies. The ethnographic literature analyzed revealed that group sizes fall into three quite distinct classes: small living groups of 30–50 people (overnight camps), large population units (tribes) of 500–2000 people, and an intermediate level of grouping (village) of 100–200 people. The average sizes of these three are 37.7, 1154.7, and 148.4, respectively. The latter has a range of 90–221.5,  $N=9$ . If all available data are considered (taking the median when only a range is available), the mean is 134.8. If only nomadic hunter-gatherer societies are considered, the mean is 156.4. None of these differ significantly from the predicted value ( $z=0.431$ ,  $p=0.667$  2-tailed). The author of the cited study provided account of many historical examples drawn from historical and ethnographic literature: “The mean size of 179.6 for the twentieth-century armies ... does not differ significantly from the 147.8 predicted value of the Dunbar’s equation ( $z=0.913$ ,  $p=0.361$  2-tailed).”<sup>63</sup> In the case of the

---

<sup>63</sup> See details in Table 4.2.

Hutterites communities, group size is explicitly limited at 150. When the number of individuals is significantly larger, it becomes difficult to control behavior by means of peer pressure alone (Hardin, 1988). Rather than creating a police force, as the anthropologist suggested, they prefer to split the community.



*Figure 4.1.* Distribution of group sizes in traditional societies.

*Note.* Reproduced from Dunbar (1993). The original footnote reports: "Individual societies are placed along the abscissa in arbitrary order. The group size predicted by equation (1) is indicated in the horizontal line; 95% confidence limits around this value are indicated by the dotted lines" Sources: Table 4.2 (Appendix D).

The same happened in settlements in New Guinea (Forge, 1972). Naroll (1956) instead carried out a study on a mixed sample of hunter-gatherers and large-scale agriculturalist and found a threshold size of 500, beyond which social cohesion needed authoritarian officials. Other studies suggesting an upper limit in group size are found in ethnographic literature. For instance, Johnson (1983) found:

On both theoretical and empirical grounds that both central tendency and maximum potential range of variation in camp size among a variety of pastoral nomad groups is heavily constrained by limitations on the ability of individuals and small groups to monitor and process information in decision-making contexts. (p. 175)

Another interesting view was recently prepared by Feinman (2010), who asserted that small groups "...often dampen the emergence of decision-making hierarchies; alternatively, large, more collective, or democratic formations may necessitate greater administrative or hierarchical political complexity per capita than is found in more autocratic groups of comparable size" (p. 37). This might explain why smaller groups may decide to merge to build a larger organization.

Dunbar (1993a, 1993b) also illustrated the role of social grooming in group size.<sup>64</sup> His point was that language evolved as a cheap form of social grooming, thereby enabling the ancestral humans to maintain the cohesion of the unusually large groups required for survival in difficult environments. Language may have evolved as a consequence of the need to increase group size (and not merely an exchange of information). Language is a bonding mechanism in humans. First, individuals prefer to spend time with their preferred social partners, which enables them to acquire information about each other's behavior by direct observation. Second, language permits the acquisition of information about third-party social relationships, enabling an individual to acquire knowledge of the behavioral features of other group members without actually having to observe them in action. Language is explained as an "efficient" bonding mechanism and that it measures efficiency with the maximum number of simultaneous "interactants" during a social interaction.

---

<sup>64</sup> Prediction of percentage of time devoted to social grooming, assuming that group size is a determinant.

Dunbar reported results from experiments conducted on conversational groups. In these experiments, the distance between the speaker and the listener and the number of simultaneous conversations among people was relevant; there seems to be a limit in the number of people that can take part in a conversation. This depends on the environment where the conversation is taking place but also on the physical long-term “information-storage” limitations of the brain reported in other studies, such as Cowan (2000), Cox et al. (1999), and Miller (1955). His fundamental argument was the following: “There is a cognitive limit to the number of individuals with whom any one person can maintain stable relationships; this limit is a direct function of neocortical size, and this, in turn, limits group size” (Dunbar, 1993a, p. 691).

The author of the present study proposes two possibilities in response to Dunbar. First, the predicted group size is a limit that reflects demands made on ancestral human populations at some point in their past history; as neocortical size evolves, other factors may dictate the need for smaller groups. Second, the limits imposed by the neocortical volume are applied to the number of individuals with whom a stable interpersonal relationship can be maintained; no prediction as to the structure of groups can follow.

The number 150 in group size has been widely popularized and entitled “Dunbar’s number” after his 1993 publication. The number has been applied in social sciences, and, in particular, to the study of social networks.<sup>65</sup> This cognitive limit has

---

<sup>65</sup> An everyday-life example is represented by the online social network Facebook. A detailed study of Facebook’s global statistics is surprising: In May 2011, among the 721 million individuals defined as active users worldwide, the average active user had less than 200 contacts. The research reported is authored by Ugander et al. (2011): “Indeed, most individuals have a moderate number of friends on Facebook, less than 200, while a much smaller population have many hundreds or even thousands of friends. The median friend count for global users in our study was 99. The small population of users with abnormally high degrees, sometimes called ‘hubs’ in the networks literature, have degrees far larger than the average or median Facebook user. The distribution is clearly right-skewed with a high variance, but it is notable that there is substantial curvature exhibited in the distribution on a log-log

been explored in many writings by the same author, who has included an abundance of historical and experimental evidence. One of the applications concerns the size of networks and their relation to language and human memory (Bickart et al., 2011; Dunbar, 2003; Dunbar, 2012; Hill & Dunbar, 2003; Stiller & Dunbar, 2007).

The contribution of the social brain hypothesis to the theory of a group size threshold in institutions is remarkable, because it provides a general prediction of the optimal number of appropriators involved in the formalization process of collective action. The social brain explains why groups have been able to overcome collective action in harvesting the commons by keeping the number of interacting appropriators within the 100.2–231.1 range. This number is connected to the costs of acquiring information and acts both on the number of interacting individuals in appropriation and in participation in institutions.<sup>66</sup>

#### **4.7. Large Groups and Fission–Fusion Strategies**

The present section addresses what happens to the group when the size threshold is overcome and transaction costs increase above the capacities of the human brain to handle the processing and storage of information. This situation is typical of very large groups. Dunbar (1993a) mentions that groups may split to cope with cognitive constraints. Olson (1965) also emphasized that “it may not be necessary [that] the entire group be organized, since some subset of the whole group may be able to provide the collective good.” Arrangements to manage collective

---

scale.” The official statistics on the website referred to 2011 (last access: 9/9/2011), reporting that Facebook had more than 750 million active users, and the average user had 130 friends. The same statistics referring to the year 2010 (last access: 16/3/2010) scored a population of more than 400 million of active users and, again, the average user had 130 friends. In one year, the population increased significantly, despite that the average user’s number of contacts remains unchanged.

<sup>66</sup> The aggregation of preferences at family level works on the household size, with daily contacts with high connections ranging from 1–9 individuals (Cowan, 2000; Hill & Dunbar, 2003; Miller, 1955). Then, the aggregation of preferences occurs below the kin group size, a close-knit group estimated at 32–34 individuals for males (Dunbar & Spoons, 1995) gathered for decision-making in community assemblies. The group of acquaintances in the community network should range from 100–231, which is the number of contacts that are involved in the collective action on resources (Dunbar, 1993b). It is expected that a community assembly of active members will include, on average, 32–34 individuals.

action can be devised by the group to structure interactions under a different “governance structure.” The importance of organization in institutions is stressed also by North (1990), as noted previously: “[G]roups of individuals [are] bound by some common purpose to achieve objectives. Modeling organizations is analyzing governance structures, skills, and how learning by doing will determine the organization’s success over time” (p. 5).

Studies have also been conducted in anthropology and sociology that relate the size of groups and networks to support cliques and kinship (Dunbar & Spoons, 1995; Roberts, Wilson, Pawel, & Dunbar, 2008; Stiller & Dunbar, 2007). In two of his writings in the early 1980s, Edney (1980, 1981) proposed decentralization as a way to solve global dilemmas before Dunbar and Ostrom. Edney declared that long-term solutions for the tragedy of the commons require “unpacking” collective action into smaller groups. He observed that cooperative behavior is facilitated when participants in a group that manages common-pool resources comprise about 150 people (Edney, 1981).<sup>67</sup> Edney asserted that the advantages of such an upper-limit threshold are appreciable in terms of improved communication. Additionally, the fragmentation of a large group into smaller subgroups allows the “diversification” of the risk of the tragedy. Shortages in one group cannot endanger the entire large group, and the impact of potential free riders is, therefore, limited. Edney observed that “the improved focus on the group itself, the greater ease of monitoring exploitative power, and the opportunities for trust to develop among individuals with face-to-face contact are also enhanced” (Edney, 1981, p. 28).

The link between the organization of groups and cognitive limits has been widely studied in anthropology, where a common group behavior is termed fission–

---

<sup>67</sup> “[...] the upper limit for a simple, self-contained, sustaining, well-functioning commons may be as low as 150 people” (Edney, 1981, p. 27).

fusion. Fission and fusion are literally the split of a group into clusters of a smaller size and the merger of two or more small groups into a larger cluster entity, respectively. These two dynamics were studied first by primatologists to investigate how primates are able to overcome ecological constraints (Lehmann, Korstjens, & Dunbar, 2007); however, related research has recently extended to human societies:

We...propose that the term “fission–fusion dynamics” be used to refer to the extent of variation in spatial cohesion and individual membership in a group over time. As a consequence, any animal society can be characterized by its degree of fission–fusion dynamics, which can vary from highly cohesive with stable group membership to highly fluid with either relatively stable or flexible subgroup membership. (Aureli et al., 2008, p. 628)

According to this strand in the literature, the fission or fusion of groups is related to the size of the group, which is in turn related to the amount of time required for (a) information acquisition and dissemination (defined by Lehmann et al. (2007) as “social time,” which acts as an opposing force to fission), (b) seeding and moving (in Dunbar’s model determined also by climate and diet), and (c) resting time (enforced by seasonality). These factors result in an ecologically determined “subgroup size” (Grove, Pearce, & Dunbar, 2012).

Recent studies often relate group size with the organization of groups, suggesting that social groups normally structure their interaction in hierarchies, which follow similar rules both in human and non-human primates and have on average between three and four layers (Bonabeau, Dagorn, & Fréon, 1999; Hill, Bentley, & Dunbar, 2008): “[...] rather than a single or a continuous spectrum of group sizes, humans spontaneously form groups of preferred sizes organized in a geometrical series approximating 3–5, 9–15, 30–45” (Zhou et al., 2005, p. 439).



The size of social networks is also limited. Hill and Dunbar (2003) studied the exchange of Christmas cards to examine social network size in humans and found that the average network size is remarkably close to 150, Dunbar's number (Hill & Dunbar, 2003; Kudo & Dunbar, 2001). These findings led Dunbar to first develop a theory of the evolution of language in humans.

The social brain hypothesis states that social group size is limited by the organism's ability to manage its social relations at the cognitive level (Dunbar, 1998, 2003). One consequence of this hypothesis is what economists call bounded rationality, and another is that transaction costs are an increasing function of group size. The field of neurosciences has recently confirmed that human cognitive limits may affect group size.<sup>68</sup> In later research, Dunbar found that the "support clique" size is determined by memory constraints and numbers around 20 individuals (Stiller & Dunbar, 2007). The frequency and intensity of contacts also matter. High-frequency contacts, the "support group," are managed by the "working memory," which is able to store and process only a few variables and items at once from the "magic" range of "7 plus/minus 2" (Aiello et al., 2010; Cowan, 2000; Dunbar & Spoons, 1995; Halford et al., 2005; Hill et al., 2008; Miller, 1955) until the limit of 15 occurs for the number of individuals in the circle of "acquaintances" (Stiller & Dunbar, 2007).

Other studies in anthropological archaeology, even prior to Dunbar's, have concerned regularities in group size in human societies and refer to the existence of a threshold in long-term memory and the formation of groups of different sizes (Kosse,

---

<sup>68</sup> For instance, a correlation is found between social network size and the volume of the amygdala (Bickart et al., 2011). The orbital prefrontal cortex is a part of the brain approximately located in the frontal part of the human brain, just behind the eye balls' orbits. It is an almond-shaped part of the brain which research demonstrated to have a primary role in the formation of long-term memory and emotional learning. In a study comparing the social brain hypothesis also at a within-species level, Dunbar finds a significant linear relationship between the volume of the orbital prefrontal cortex and the size of social networks (Powell et al., 2012). This region of the brain, widely observed by neuroeconomists, is thought to influence the cognitive processing of decision-making and governs emotions and reward.

1990, 2001). In Chapter 5, the discussion will focus on the impact of these limits in the determination of the appropriator's group size. Considering the common agreement of local historians in estimating the average household size as five individuals (Chiocchetti, 1983; Debiasi, 1953; Garbellotti, 2006), it is easily obtained with an average estimate of 100 to 300 appropriators on the commons under a formal regime, which is consistent with the predictions of Dunbar (1993b) as well as the results obtained by Hill and Dunbar (2003).

The organization of collective action in groups of a size different from the optimal one has been explained by the science of networks. In large real-world social networks, nodes (individuals) exhibit a tendency to create sub-groups termed clusters. Clusters are close-knit groups characterized by highly dense contacts, increasing the likelihood that any two nodes within the cluster, compared to any two nodes in the broader social network, will establish a tie (Watts & Strogatz, 1998). Networks with high local clustering ("village networks" and "clustered decentralized networks") are normally more efficient in information transmission, because they are characterized by shorter average paths, shorter network diameters, higher average degrees, and higher density than centralized networks ("wheel" networks) (Borgatti, Mehra, Brass, & Labianca, 2009; Marwell, Oliver, & Prahl, 1988; Siegel, 2009). Results of fieldwork and experiments in human anthropology have shown that even when group members appear to interact in larger networks, they actually interact in smaller "circles" or clusters so that social interactions are structured in multiple "layers" of different intensity and cognitive manageability (Stiller & Dunbar, 2007). The tendency to stabilize this size of social interactions, fundamental in a face-to-face society, may lead to institutions in which interactions are sized according to the interactants' cognitive limits.

Stiller and Dunbar (2007), interestingly, note the following:

In effect, an individual sits in the centre of a personal social network that has the form of a series of concentric circles of acquaintanceship containing, roughly, 5, 15, 50, 150, 500, [and] 1500 individuals, with their circles reflecting successively declining emotional closeness and frequency of contact (Hill and Dunbar, 2003). (Note that each of these values is inclusive of the groupings within them.) This consistency raises the question of what limits network size at any given level. (p. 94)

From the institutional standpoint, these findings underline the importance of clustering social interactions in “cliques” in face-to-face societies as a basis for managing large-scale collective action at lower transaction cost.

#### **4.8. Conclusions**

The literature reviewed in this chapter allows a formulation of the threshold hypothesis under the following terms: (a) institutions for the management of the commons having the requirements listed by Ostrom (1990) (b) transform from informal to formal institutions (c) when they overcome the group size threshold; (d) the threshold is included in Dunbar’s range; and (e) after crossing the threshold, (f) large groups structure their internal organization in smaller sub-groups.

This statement (a) identifies the institutional context under analysis, (b) is the institutional change the present research is designed to explain, (c) describes the behavior to observe, (d) defines the link with the “general” threshold needed to observe to confirm the hypothesis, (e) denotes the transition to be observed to make claims as to the role of organization in large groups, and (f) validates the observation of large groups with respect to the general group size threshold to confirm the hypothesis. A straightforward visualization of this hypothesis is in the framework

illustrated in Chapter 1 (Figure 1.1). The rationale of a threshold-driven institutional change is linked to the minimization of transaction costs in institutions. In principle, this change may lead to a more efficient allocation of resources than in alternative regimes.

The goal of the next two chapters will be providing empirical support for the existence of a critical size threshold in the transition to a formal institution and for the existence and rationale of fission–fusion strategies in institutions.

## Chapter 5: Group Size Thresholds in Institutions

*Even with agreement that group size refers to the number of individuals, there is no consensus on the turning point between small and large groups. What is a small group? To what extent, if at all, does the assessment of size depend on context? How is context important and why?—(Poteete & Ostrom, 2004)*

### 5.1. Introduction

The present chapter seeks to identify the group size required for successful collective action in the commons based on analysis of the *Carte Di Regola* in the Trentino region. The main finding is that, while population almost tripled in the region during a period of six centuries, the mean community size remained stable.

The first goal of this chapter is to explain what determined the observed group size in these communities. The focus is on the “Appropriators’ group size” which corresponds to the number of individuals in the “insider” group, those who are entitled to access and use the commons included within the boundaries of the community. This concept is distinct from “community population size”, which is broader and includes also non-members (outsiders) living in the community.

The second objective of this chapter is to offer empirical support for the existence of a group size threshold that may be responsible for driving change from an informal to a formal institution. The existence of a group size threshold might explain the stability of the group, as differences in group sizes correspond to different forms of property rights allocation and to different forms of internal organization.

This section illustrates alternative explanations for group size variations in institutions, and why this study’s conclusions is that transaction costs<sup>69</sup> mattered in

---

<sup>69</sup> For a definition, see Appendix A.

producing the result summarized above.

According to economists, the allocation of property rights is a welfare maximization problem. For example, in a study on transaction costs, Douglas Allen asserted the following: “Every distribution of property rights has with it a set of production costs and a set of transaction costs. The distribution of property rights that maximizes the gains from trade, net of all costs, is the optimal distribution” (2000, p. 900).

Thus, the determination of group size in institutions may be led by factors related to production costs (extraction of the resource) and factors related to transaction costs (Allen, 2000; Allen & Lueck, 2002).

An alternative explanation of group size and institutional change besides transaction costs could be based on production costs. The evidence shows that considering only production costs might lead to a partial, if not misleading, result. This chapter provides empirical tests for five factors: resource specificity, free-riding, transaction costs, heterogeneous individual preferences, cognitive limits. This list is not exhaustive of all the possible factors, and these factors are not mutually exclusive. A brief review of each of the factors illustrates their common denominator and justifies the assumption of the existence of a group size threshold.

*Factor 1 – Resource specificity.* Group size differences may be due to “resource specificities” because of different production costs, and in particular of different economies of scale across resources. This claim is based on the assumption that different resource types can have different production functions.

*Factor 2 – Free-riding.* A second factor is that there might be differences in the magnitude of the incentives offered to the individual in groups of different size, where these incentives are dependent on non-cooperation (Hardin, 1968; Olson,

1965). In this case, large non-cooperating groups are assumed to fail and only small groups to survive. As the non-cooperation assumption is relaxed, however, the argument clashes theoretically with the paramount evidence contained in the scholarly production of Ostrom. Large groups succeed in managing the commons by transitioning to a formal institution (Ostrom, 1990).

*Factor 3 – Transaction costs.* The free-riding argument neglects the existence of costs besides the direct costs of production incurred by individuals when taking part to an economic exchange. In practice, economic exchanges involve also three types transaction costs: search and information costs, bargaining and decision costs, policing and enforcement costs (Dahlman, 1979). Assuming no transaction costs can lead to widely different implications for the designs for institutions and the allocation of property rights.<sup>70</sup>

Concerning the first two factors, the first case of the free-riding “problem” would not be a problem if individuals cooperated at zero transaction costs, regardless of the size of the group. In the second case, differences in group size could be explained only with groups experiencing difficulty in the management of resources that require different levels of monitoring costs. This statement logically transforms the resource specificity argument into a subcase of the transaction cost argument. If the argument is true, it should be possible to observe formal institutions in groups where transaction costs are higher. Setting up a formal institution is aimed at minimizing these costs, also in which case the free-riding argument would become a subcase of the transaction cost argument. The institutional change may thus be considered led by the higher net benefits that the group may enjoy in investing in a

---

<sup>70</sup> According to the Coase theorem (Coase, 1960; Cheung, 1969), in a positive transaction world the cost-benefit decisions of the individuals are affected by the presence of externalities. The presence of externalities in exchanges has notable consequences for welfare-maximizing reallocations of property rights on resources: in this case, institutions function as constraints on market agents’ behavior (Eggertsson, 1990; North, 1990).

formal institution when its size grows (Demsetz, 1967). If transaction costs are positive and increasing with group size, the transition to a formal institution should be inherent to different group sizes, and a formal institution is expected to be peculiar of large groups.

*Factor 4 – Heterogeneous individual preferences.* Further support to a transaction-cost grounded difference in group sizes is in the mechanisms of collective action once the group decides to bear costs to set up an institution and interact in assemblies for managing the group. Large groups normally find it difficult to aggregate consensus due to heterogeneity of individual preferences toward risk, and this difficulty, aggregation of preferences (Factor 4), is again related to transaction costs related to the moment in which individuals gather to make decisions in assemblies.

*Factor 5 – Cognitive limits.* The existence of a group size threshold is compatible only with an institutional change driven by transaction costs. It will be considered explanatory of the whole process if evidence is found in line with Dunbar's hypothesized group size range and the social brain hypothesis (1993a, b, 1998). Collective action of face-to-face groups is "easily" solved where group size is below an upper bound because of the existence of a threshold in the number of interpersonal contacts that an individual can manage within his or her memory. This chapter claims that this latter factor is crucial for collective action in the commons, as one of the problems leading to the tragedy is precisely the lack of coordination and cooperation among an undefined number of users of an open access resource.

For ease of interpretation of the results, in the process of institutional change population growth was assumed to be exogenously determined. This assumption, in both Chapters 5 and 6, was made to consider changes in population as independent



from the institutional type and organization changes. Consequently, institutions and organizations were presumed to adapt to increasing or decreasing population growth. In particular, groups with larger initial population were deemed to have faster technological change and population growth (Kremer, 1993).

The organization of the chapter is the following. Section 5.2 discusses each factor, and develops testable implications. Section 5.3 presents statistical analyses and empirical support for each argument. Section 5.4 offers a synthesis of the findings, and concludes.

## **5.2 Methods.**

This research studied factors determining group size in relation to the two dimensions of collective action outlined in the framework. Recall the distinction between direct appropriation of the commons (“appropriation”) and the creation of institutions (“participation”): the two collective actions share the common feature of referring to groups of individuals interacting directly (face-to-face).<sup>71</sup> The former type of collective action, “appropriation”, consists of the costly transactions of an informally interacting group, sustained by rules of cooperation that characterize an informal institution. The collective action in institutions, “participation”, focuses on group decision-making—for instance, through a system of assemblies—toward enacting a formal institution.

The analysis proceeds by examining the five factors and testing which of them

---

<sup>71</sup> This distinction allows separating this type of collective action from others that are not of interest in this dissertation. For instance, collective action of groups in indirect democracies is not considered. Parliaments are structured decision bodies based on indirect representation of the interest of electors, and although treated by a rich body of literature, the size of contemporary parliaments, and every other collective action mechanism in state-centered legislatures, falls outside the scope of this thesis. In these cases, the individual incentive to reach the common goal in group decisions may be sustained (and to a certain extent determined) by economic interest (i.e., salaries). A principal-agent logic governs these situations (Shepsle, 1989, 2010). Another case not considered is the choice of the optimal size of a firm to organize production (Coase, 1937; Cornes, Mason, & Sandler, 1986; Williamson, 1967): Although this choice concerns group behavior in hierarchical organizations, the institutions studied in this case involve at times multiple villages organized in “horizontal” coordinating governance structures.

are most important in explaining the existence of a threshold in group size. Two sections illustrate the economies of scale (Section 5.2.1) and the “free-riding” argument (Section 5.2.2), usually made by scholars in rational choice, environmental, and development studies. Three subsections discuss the role of transaction costs in influencing the size of the appropriators’ group (Section 5.2.3); of heterogeneous individual preferences (Section 5.2.4); and, finally, of “cognitive limits” (Section 5.2.5). Each section includes the elaboration of testable implications concerning group size in light of each factor.

Section 3 contains empirical analyses on the full sample of communities in six selected years (1350, 1450, 1550, 1650, 1750, and 1800), which used population as a proxy to estimate the number of potential appropriators in each community. As a second stage, the same section posits how group size differed in relation to different levels of participation. The level of participation is proxied by the deliberative quorum of a large sample of village assemblies. The number of active members in community assemblies from 1249 through 1796 was used as a proxy for participation. The section tests the existence of an upper bound threshold value by estimating the number of directly interacting appropriators on the commons. Using the data of participation at community assemblies and the attendance quorums reported in the documents, an estimate of the effective number of appropriators that is superior in quality to population was computed; however, this was obviously restricted only to communities adopting a formal institution where it was possible to observe a complete list of attendance. The datasets used for the analyses are listed in Table 3.6 and described in Subsection 3.3.2 (Chapter 3).

**5.2.1. The resource specificity argument.** Group size may be resource-specific. The production function in appropriation can be different if the resource is a

forest or pasture. It is possible that communities basing their economy mainly on forests have a population different from communities with a prevalence of pasture, even when assuming the optimal scale of production is adopted and that the communities have the same extension in terms of hectares. It follows that group size may be resource-specific. This argument is explicit and at times implicit in most studies in natural resource management (Agrawal, 1998; Baland & Platteau, 1996).

Why should there be a difference?

Consider the simple case of a community in which the output in production follows a Cobb–Douglas function of a combination of inputs required to produce output  $Y$ : labor  $L$  (number of workers) and land  $K$  (hectares). When doubling the amount of labor and land, the output doubles and economies of scale are constant ( $\alpha=1$ ). When doubling the amount of labor and land, the output more than doubles, and economies of scale are increasing ( $\alpha>1$ ). In this case, returns to scale are increasing. This means that when  $L$  and  $K$  both increase of  $\alpha$ , the increase in the output  $Y$  is greater than proportional to  $\alpha$ .

Three factors may affect the maximum group size.

The first factor is the surface extension of the land. Land resources have boundaries demarked by the environment (orography) or by the law (property rights). If a community wishes to produce the optimal amount of output, if this amount is proportional to the productivity of land resources (which is resource-specific), the amount of labor (group size) to produce the optimal amount of output should be resource-specific as well. Hence, it is expected to find a maximum group size determined by the physical characteristics of the land (Field, 1989).

The second factor is the amount of resource endowments of a group included in the surface. As the number of appropriators increases, fixed costs in production can

be spread over a larger base (Agrawal, 1998; Archetti, 2009). The practical implication for this argument is that group size should be related to the resource endowments of the group. Large endowments of land resources should lead to a higher output and “feed” a larger group. Small endowments, instead, lead to smaller group size.

The third factor is the growth rate of the resources. Each resource type has its own biologic growth rate (Clark, 1990). The complete exhaustion of a forest area leads to the impoverishment of a community for 40 years, while the exhaustion of a pasture area requires a “sleeping” period of only one or two years (Castellani, 1982; Pearson & Ison, 1997). The output  $Y$  and therefore the level of revenue on output are also influenced by random shocks, historical events affecting production, and/or the demand for legal institutions. When relative prices of timber and milk increase, payoffs for cooperation in such areas of production can be higher.

The list is not exhaustive. Other factors affecting group size through resource specificity are climate, warfare, pestilences or famine, or other historical events, which may affect the output level, labor, or capital (Barzel, 2001; Perini, 1852; Tovazzi, 1986).

**5.2.2. The free-riding argument.** The larger the group the more frequent is free-riding in resource appropriation. The issue of group size has been a concern tackled by Ostrom in the following terms:

The central question...is how a group of principals who are in an interdependent situation can organize and govern themselves to obtain continuing joint benefit when all face the temptation to free ride, shirk, or otherwise act opportunistically. (Ostrom, 1990, p. 29)

The traditional view on large groups, later criticized by Ostrom (1990), may

be described as relying on the assumption that there is an intrinsic conflict between individual and public interests. If the individual is self-interested, collective action problems are exacerbated due to the free-riding temptation (Gordon, 1954; Hardin, 1968). Amongst its limitations, this argument does not make any quantitative prediction about a minimum or a maximum group size in collective action; the issue of size thresholds is not treated in Olson's work, either. The fundamental claim is that small groups are more successful than large groups in collective action.<sup>72</sup> Olson's contribution focuses on public (and not common) goods and has been studied extensively by others through simulations as well as empirical and experimental studies (Agrawal & Goyal, 2001; Chamberlin, 1974; Esteban & Ray, 2001; Oliver & Marwell, 1988). The basic theory driving the studies that manifested after the Olson study is that the larger the group, the smaller the capacity of one actor to cover the costs of coordination and, consequently, the larger the discomfort in the group. Under this argument, it would be expected that only small communities are able to engage in successful collective action.

One issue is whether group size really increases the temptation to free ride independently on the context. One may argue that large groups have a higher "punishment potential" with respect to smaller ones against a possible free rider.<sup>73</sup> By following the Olsonian argument, it can be concluded that, in general, the temptation to free ride increases with group size. However, empirical evidence exists contrary to this prediction. It would be more prudent to determine that whether an increase in group size corresponds to an increase in temptation to free ride depends on the

---

<sup>72</sup> In *Governing the Commons*, Elinor Ostrom writes: "I focus entirely on small-scale CPRs, where the CPR is itself located within one country and the number of individuals affected varies from 50 to 15,000 persons that are heavily dependent on the CPR for economic returns" (Ostrom, 1990, p. 26). As reported in the quotation at the beginning of the chapter, also for her, there must be a "turning point," which is equivalent to what has been defined as threshold group size in the present study.

<sup>73</sup> Thanks to Vincent Buskens for having raised this point.

context.<sup>74</sup> Thus far, the literature contains no clear evidence on the role of punishment for free-riding in groups of different size. For the purpose of this chapter, the issue may be considered implicit in the *ceteris paribus* assumption.

Making the issue explicit requires assuming that punishment potential does not differ in large and small groups (communities). The assumption is grounded on theoretical and empirical arguments and can be offered without loss of generality. As to the theoretical arguments, the assumption is based on recent findings from experiments on public goods. The (variable) punishment potential of the group is certainly an element that affects the levels of cooperation in a small-scale society. Nevertheless, it is also true that experimental evidence today is not able to confirm with certainty the role of punishment institutions on the relation between group size and free-riding.

Recent studies found that small-scale societies developed costly “altruistic punishment” institutions aimed at increasing cooperation levels (Fehr & Gächter, 2002). In these experiments, group size is interpreted as hindering individual monitoring potential and encouraging violations. The introduction of arrangements in the group to make deviations from cooperative strategies unprofitable for potential defectors is a solution to sustain cooperation. The whole group bears a part of the

---

<sup>74</sup> The problem posed by the example is one of rule enforcement: This problem is called “punishment potential,” the ability of detecting and inflicting sanctions in a society. An example may clarify the terms of the problem:

*Example.* Let us consider two groups (communities), A and B, which are identical as to environmental setting, individual characteristics, and everything else, differing only in terms of size: A is small, B is large.

Where is free-riding more likely: in A or B? A traditional economic argument (Becker, 1968) would be that the probability of getting caught is low in the large community (B) and high in the small community (A), regardless of the intensity of the sanction (even if there were a “draconian” punishment, like capital punishment), and therefore, free-riding is more likely in the large group (B). Why? The deterrent potential of the rule is lower in the large community than in the smaller. This means that the expectation of (monetary) gain from the defection for the violator is higher in the large community than in the smaller, where the violator could be more easily caught and punished. Detecting and sanctioning a violator is, therefore, more expensive in a large group than in the smaller. If the marginal costs of punishment are higher than the benefits of getting the violator, the incentives of the violator to free ride are reasonably higher in the large community than in the smaller, because his action is more likely to go unnoticed.

costs of the establishment of the rules of monitoring and punishment and of their enforcement. Experimental evidence has shown how the emergence of altruistic cooperation is easier when groups are smaller, because mutual monitoring is easier. Larger groups have to cope with insufficient monitoring and ineffective punishment potential with the introduction of punishment rules as well as face higher enforcement costs per member (Boyd, Gintis, Bowles, & Richerson, 2003). These costs are higher in larger groups, because anonymity and escaping from monitoring, and free-riding, are more easily achieved in larger groups. Concomitant with this view, large groups would need a larger punishment potential to sustain cooperation.

On the other hand, criticisms have been raised about the claim that costly punishment increases cooperation (Saaksvuori, Mappes, Puurtinen, & Sa, 2011; Wu et al., 2009). The absence of free-riding and the promotion of cooperation may depend on the ways in which sanctions are assigned by peers. For instance, the absence may depend on individual decision rules or on collective decision rules (Miltenburg, Buskens, & Barrera, 2012) as well as developing centralized sanctioning or legitimate authority in complex societies (Baldassarri & Grossman, 2011). The effectiveness of punishment in deterring free-riding may be affected by group internal diversity so that, in smaller groups, harsher rules may work better because mutual monitoring is weak. Conversely, milder rules may work in large homogeneous groups.

Other criticisms have been raised against the claim that costly punishment works better in large groups than in smaller groups. According to these criticisms, large groups do not need a larger peer-punishment potential to sustain cooperation. For instance, Carpenter (2007) established that, theoretic grounds aside, punishment would not deter free-riding regardless of the size or structure of groups. The same author found that experimental evidence indicates that people apply costly

punishment and that large groups “contribute at rates no lower than small groups because punishment does not fall appreciably in large groups...hindrances to monitoring do reduce the provision of the public good” (Carpenter, 2007).

Experimental results abound on the impact of punishment and group size on behavior in public good games; however, the evidence in these studies must be considered carefully (Pedersen, Kurzban, & McCullough, 2013). The game environments used thus far have not allowed free riders to be sanctioned. Even so, they have not allowed for groups of the size of the typical community in the present study (in the order of hundreds), while, for instance, the Isaac and Walker (1994) study used groups of at most 100 individuals and the Boyd et al. (2003) study groups of up to 256 individuals. Only Baldassarri and Grossman (2011) conducted a study on a large group (of 1,543 individuals). In addition, the experimental conditions have had very different characteristics from the typical community, as they were lab experiments or based on computer simulations.

The free-riding argument suffers of three main limitations.

The first major limitation is that it is based on a simplification of the Olsonian argument and on a *ceteris paribus* assumption that is functional to the research question in this dissertation (i.e., whether there is an increasing or decreasing relation between group size and free-riding). The answer, as explained, can be provided independently on consideration of the punishment potential of a larger group both under the *ceteris paribus* assumption and under the “equal punishment potential” assumption.

The second limitation is that this argument seems to neglect all the details of the contexts in which a group happens to act and cannot account for all the recent experimental evidence. This context dependency may also not be relevant under the



assumptions offered above.

The third limitation is intrinsic in the data: punishment potential cannot be observed in detail. However, in Chapter 8, the increasing role specification with group size (measured as the number of roles in an assembly) is reported. This contingency might imply that more role specification may reflect the need to ensure the enforcement of punishment or the emergence of specific enforcement roles (e.g., community police officers). Thus, to sustain cooperation in a formal institution, a more complex society is required. Notwithstanding these limitations, the free-riding argument is sound. One of the possible tests that will confirm or reject the argument examines whether only small groups are able to cooperate or if large groups are able to find ways to control free-riding and under which conditions small and large groups are able to overcome social dilemmas.

**5.2.3. The transaction costs argument.** Transaction costs increase with group size. Large groups face high transaction costs in appropriation because of increasing costs of collecting information about others' behavior and about the levels of exploitation of the common resources. Transaction costs offer an alternative to resource specificity in explaining why groups may differ in size according to the type of resource(s) with which the community is endowed (Allen, 2000). Transaction costs were analyzed in relation to cooperation for collective action, individuals' temptation to free ride, and group size.

Collecting information in the forest may be more costly than in other resource settings, and payoffs would differ depending on the resource. Different types of resources mean different costs of monitoring and enforcing punishment rules. The information cost structure in a forest area is different from that in a pasture area. The individual costs of obtaining information may be different in different resource

environments, and these costs affect the payoffs of individuals when they have to decide whether it is worth cooperating with others. This theory has been formalized in game theory with the concepts of “imperfect monitoring” and “discount factors” in games that are repeated for more than one round, such as the prisoner’s dilemma. In the prisoner’s dilemma, there is no need to gather information about the other player’s strategy, nor is there a way to predict because of the impossibility of communication. Instead, when interaction is repeated, players may capitalize on information acquired from the previous game round. Axelrod and Keohane (1985) note that the propensity of actors to cooperate is affected by three situational dimensions: mutuality of interests, the shadow of the future, and the number of actors.

In particular, Axelrod and Keohane (1985) proposed that long-term cooperation is possible under the “shadow of the future” when actors are concerned about the future. The key drivers of cooperation under the “shadow” are (a) long time horizons, (b) regularity of stakes, (c) reliability of information about the others’ actions, and (d) quick feedback about changes in others’ actions. In repeated games, players may also sign contracts and form expectations as to the future strategies of agents, and assign value to them. The folk theorems predict that when players have sufficient information on each other and foresee interactions in the future, cooperation may be sustained indefinitely if players are sufficiently patient (Abreau, Pearce, & Stacchetti, 1990; Fudenberg & Maskin, 1986).

Low discount rates are associated with higher individual payoffs, meaning that when the costs of interaction are lower, cooperation can be sustained in the long run. At times, the group may also bear the cost to set up a sanctioning system to detect and punish defectors with monetary or physical sanctions. This choice has been discovered by recent research to be beneficial for cooperation and to reflect the

information cost structure of a group (Boyd, Gintis, & Bowles, 2010; de Quervain et al., 2004; Fehr & Gächter, 2000, 2002; Gächter, Renner, & Sefton, 2008; Henrich et al., 2006, 2010; Herrmann, Thöni, & Gächter, 2008; Kandori, 1992; Rockenbach & Milinski, 2006; Sigmund, De Silva, Traulsen, & Hauert, 2010). Transaction costs as the costs of allocation and protection of property rights can be interpreted as the costs of acquiring information about the level of exploitation of different types of common resources and others' behavior (Dahlman, 1979; Field, 1989; Williamson, 1979, 1981). Uncertainty in property rights allocation and protection is associated with higher costs of information and may affect the aggregate social payoff. "...people are expected to cooperate in sharing the information, rewarding its producers and preserving it by developing means such as writing" (Barzel, 2001, p. 17).

In communities characterized by close-knit interaction, it has often been found that a small group size has allowed the adoption of "welfare maximizing norms" (Baland & Platteau, 1996; Cole & Wolf, 1999; Ellickson, 1991; Ostrom, 1990; Ray & Bhattacharya, 2011; Viazzo, 2006; Wade, 1988).<sup>75</sup>

The transaction costs argument includes the prediction of the free-riding argument. Recent studies on the commons have led to the conclusion that Olson's theory is not supported by field evidence. Sometimes, large groups overcome collective action problems, and some studies have found consistently decreasing free-riding as the group increased in size (Carpenter, 2007; Oliver & Marwell, 1988). Before Olson's logic, Buchanan and Tullock already predicted that large group size would lead to higher benefits that, eventually, offset the costs of coordination (Buchanan & Tullock, 1962). The "transaction costs" argument states that monitoring and enforcement costs are necessary to guarantee the acquisition of information for

---

<sup>75</sup> Harsher punishments are expected to be found where monitoring and enforcement requires specific investments in information (i.e., monitoring during nighttime, in forest or meadows).

the optimal allocation of property rights and that these costs increase with group size; therefore, according to the argument, large groups are usually groups where there is a high level of aggregate rents but also high levels of costs to acquire information.

The transaction costs argument integrates also a gap left by the resource specificity argument, which, taken literally, allows for a theoretically unlimited increase in group size if resource availability is unbounded (Agrawal, 1998). The transaction costs argument predicts that group size will increase until the group no longer obtains positive benefits from rents from production and transaction costs. The lack of sustainability of an excessively large group is revealed by severe transaction costs increasing due to difficult information flows that render the group ultimately unstable (Carley, 1991). The implication for the present study is that groups that are excessively large, to cope with information and transaction costs, may structure in subgroups (fission) to improve information transmission and lower the costs of acquiring information. Non-stable social groups are characterized by altered information flows, and usually non-stable groups are too large in size (Carley, 1991). In such groups, a solution to cope with instability would be the fission of the group into smaller sub-groups (Aureli et al., 2008; Lehmann et al., 2007).

**5.2.4. The heterogeneous preferences argument.** The larger the group the more difficult is finding a common agreement. In a group, individual preferences may differ along many dimensions, such as (a) individual differences generated by individual levels of impatience, (b) tolerance for risk, (c) individual willingness to engage in certain effort/compensation ratios, and (d) individual endowments (human capital, utility, etc.). Preference aggregation is more “difficult” in groups with heterogeneous individual preferences. Larger groups are more likely to be heterogeneous. This argument can explain why a large group might be unable to make

collective choices that are not later overturned, while smaller groups might reach a decision that is stable over time more effectively.

The “heterogeneous individual preferences” argument focuses on the aggregation of individual preferences to achieve a collective choice. Olson’s argument is based on the independence of individual choice, while the heterogeneous preferences argument considers group choices after a strategy to reach an agreement has been chosen. This argument assumes that once the collective decision has been taken, its implementation is automatic. The argument is submitted to more extensive testing in Chapter 8.

This argument contemplates three interlinked aspects of heterogeneity in collective choice: the existence of heterogeneity of (a) income, (b) preferences, and (c) wealth as sources of disagreement (Erlei, 2008). A recent empirical study demonstrated the existence of a link between conflict and wealth inequality and polarization (Esteban & Ray, 2011). Any sort of diversity in individuals’ heterogeneity in income or preferences (e.g., non-convergence in religious creed, ethnic origin, etc.) negatively affects participation levels (Alesina & La Ferrara, 2000). This argument is backed by an established body of literature in economics and public policy, some with convincing historical examples (Brown, 1975). Heterogeneity affects the aggregation of individual preferences.<sup>76</sup> This form of heterogeneity affects group choice by rendering ineffective the majority rule, leading to cyclical voting notwithstanding that the individual preferences are not cyclical. An example may help to render the argument:

---

<sup>76</sup> Homogeneity is also associated with lower negotiation costs (Heckathorn, 1993; Naidu, 2005; Oliver, Marwell, & Teixeira, 1985; Poteete & Ostrom, 2004; Putnam, 1993; Ray & Bhattacharya, 2011). See Chapters 7–8 for a more ample discussion.

*Example.* Mike, John, and Peter have different preferences toward ice cream, beer, and coke. Mike ranks coke over ice cream, and ice cream over beer. John ranks ice cream over beer and beer over coke. Peter ranks beer over coke and coke over ice cream. If they have to decide to purchase a set of identical goods (or three cokes, or three ice creams, or three beers), what will they decide to do?

Kenneth Arrow (Arrow, 1951; Shepsle, 2010) demonstrated that the social preferences between alternatives (i.e., coke, beer, and ice cream) depend only on the individual preferences (i.e. Mike's, John's, and Peter's preferences toward coke, beer, and ice cream). This axiom is known in social choice as "independence of irrelevant alternatives" (Ray, 1973) and is one of the conditions that explained the impossibility of aggregating ranked individual preferences, known as the "Arrow's impossibility theorem" (Arrow, 1951, p. 15, 23, 27). More precisely, the impossibility theorem asserts that when voters have three or more distinct alternatives (options), no voting system can convert the ranked preferences of individuals into a community-wide (complete and transitive) ranking while also meeting a certain set of criteria additional to the independence of irrelevant alternatives: unrestricted domain (universality),<sup>77</sup> non-dictatorship (no mimicking of a single voter), monotonicity,<sup>78</sup> and non-imposition.<sup>79</sup>

In a situation with ranked non-single peaked and multidimensional preferences, as the one portrayed in the simple example above, there is no winner. Even a majority rule can be ineffective to overcome the deadlock. This situation is known in the literature as "Condorcet's paradox." At the first voting round, every

---

<sup>77</sup> For any set of individual voter preferences, the social welfare function should yield a unique and complete ranking of societal choices.

<sup>78</sup> If any individual modifies his or her preference order by promoting a certain option, then the societal preference order should respond only by promoting that same option or not changing, never by placing it lower than before.

<sup>79</sup> Every possible societal preference order should be achievable by some set of individual preference orders.

choice can pass with a simple majority and can be overturned in the next round with another decision, always with the simple majority of the votes. Super majority rules (like a quorum of 2/3) lead to decisions capable of surviving more than two electoral rounds (cyclical voting).

Group heterogeneity increases with group size until reaching a community-wide consensus becomes impossible.<sup>80</sup> Hence, the smaller the group, the lower the likelihood that the group is heterogeneous (Ostrom, 2010, p.52).

The argument is evident on a purely statistical basis. A simple example would be to assume as given the degree of heterogeneity in the population (all the inhabitants in Trentino), then draw randomly from the population two communities,  $x=100$  and  $y=200$ . Reaching an agreement in  $y$  is more difficult than in  $x$  because of the higher expected heterogeneity in  $y$  than in  $x$ , only by virtue of a larger number of individuals in the group. The practical consequence is the likely instability of choices in large groups due to cyclical preferences, as predicted by Arrow's theorem.

This generates three important implications for the management of collective action in face-to-face groups. First, if the difficulty of collective action in face-to-face groups increases with group size, the difficulty, caused by heterogeneity in preferences, can be minimized by keeping groups as small as possible. Second, if communities are perfectly homogeneous, they can decide under a unanimity rule. As heterogeneity increases, and it increases with group size as argued above, the unanimity rule is expected to be substituted by a majority rule. Therefore, the expectation is that collective decisions are taken with higher quorums in small-sized

---

<sup>80</sup> The measurement of group heterogeneity has a long tradition in sociology and economics. Olson already anticipated this concept in his theory of collective action (Olson, 1965, p. 53), and the reader may find abundance of literature referenced in Ostrom (2010, p. 52). Please refer to Chapter 7 for details. One widely used measure of heterogeneity is the "fractionalization index," computed as the probability that two randomly drawn individuals from the population belong to different types (Alesina, 2000).

groups. Third, to cope with heterogeneity in individual preferences, collective action of face-to-face groups becomes organized in more levels (i.e., splits up in smaller decision units), where agreement is easier to achieve. A first aggregation of preferences occurs naturally at a household level, meaning that the community assembly is comprised of a representative for each household (center of aggregation of economic and social interests). Second, the aggregation of preferences occurs at a community level, meaning that a large and heterogeneous community may adopt a two-layered system of assemblies where the first “bottom” layer is the community assembly and the higher layer is a sort of coordinating body, a “conglomerate” of communities: a super community (community of villages).

An important question left unanswered by this hypothesis is the existence of an optimal number that triggers such strategies of aggregation of heterogeneous preferences at the community level.

**5.2.5. The cognitive limits argument.** Large groups hardly sustain cooperation due to individual cognitive limits. Collective action is affected by the limitation of the human brain to maintain stable relationships with other people. There exists an upper bound beyond which an individual cannot keep accurate memory of acquaintances and of their history. The cognitive limits argument predicts that, in order to solve collective action, eventually the group reacts to an enlargement beyond this cognitive limit by splitting into smaller subgroups or by organizing in multi-layered structures.

The formulation of the cognitive limits argument substantially reproduces the threshold hypothesis that has been described in Section 4.8. For ease of reading, the first part of the hypothesis is in conjectural form:

*Conjecture:* Institutions for the management of the commons having the



requirements listed by Ostrom (1990) transit from informal to formal institutions when they overcome the group size threshold.<sup>81</sup>

The argument can be tested taking as landmarks the findings of Dunbar (1998, 2003) concerning the prediction obtained in his 1993a study and in light of the social brain hypothesis. The predictions obtained by the cited anthropologist (Equation 4.1, Chapter 4) report that the mean group size threshold in face-to-face interaction should be approximately 147.8. In addition, his hypothesis concerns not only the mean group size but also the limited variance of the value. The 95% confidence interval is between 100.2 and 231.1 individuals (Section 4.6.3). Accordingly, to test the cognitive limits argument and to state that it is consistent with Dunbar's findings would be to find that the size of communities adopting a formal institution is, on average, above the predicted number of 147.8 and above the range (110.2–231.1).

### 5.3. Results and Discussion

This section offers empirical evidence about group size in the context of the *Carte Di Regola* system. The evidence follows the five arguments presented in Section 5.2. The aim of this section is to test which factor is most supported by empirical evidence. For each argument, an outline of the concept is first provided, and the empirical question and the methodology used are described. Statistical analyses were carried out on the reduced panel<sup>82</sup> to find support for each of the hypotheses; findings are summarized and implications considered. Considering the nature of the data, it was preferable to use non-parametric methods (Allison, 1984; Jenkins, 2004; Siegel, 1956).

---

<sup>81</sup> The second part of the conjecture will be tested in Chapter 6.

<sup>82</sup> The dataset considers communities at six selected dates (1350, 1450, 1550, 1650, 1750, and 1800). In the descriptive analyses in the selected dates, 66 observations having missing values in population were excluded. In the econometric analyses presented in Appendix B, these observations were also included, setting population to zero and creating a dummy that returns 1 when the observation is missing and 0 otherwise (Cohen & Cohen, 1983): It was not possible to proceed to case-wise deletion in dynamic analyses, as the existence of such communities could not be excluded with certainty.

**5.3.1. Test of the resource specificity argument.** Group size was not resource-specific. The resource specificity argument can explain why large groups may be more successful than small groups in solving collective action in the commons. It is assumed that the production function with labor and land inputs exhibits returns to scale that are initially increasing and then decreasing. An optimal scale dimension should exist. Evidence is pursued of group size being different when having a prevalence of forest versus a prevalence of pasture. In the selected years (1350 to 1800), communities with a prevalence of forest have a median population that is not statistically different from that of communities with a prevalence of pasture. No evidence was found that economies of scale are a major factor in the determination of group size. First, one must reconstruct the resource endowments of each community in the reduced panel<sup>83</sup> and divide the communities in three categories: forest is prevalent, pasture is prevalent, and a residual category containing all the other observations (mixed resources and limited commons). When the medians are analyzed, a test of difference between medians of the two extreme categories is performed. The results are consistent with the argument under two assumptions put forward for the remaining part of the present chapter. The first is that once a formal institution is adopted, there is no resource specificity in efficiency. The second assumption is that, once a formal institution is adopted, the total surplus remains constant when group size increases.

---

<sup>83</sup> Recall dataset description for this chapter in Section 3.3.2.

Table 5.1.

*Is group size resource-specific?*

Informal and Formal Institutions							Formal Institutions						
Selected Year		Resource Type			Median Test		Selected Year		Resource Type			Median Test	
		Pasture	Mixed	Forest	$\chi^2$	p-value			Pasture	Mixed	Forest	$\chi^2$	p-value
1350	Median n=197	273 75	213 52	222 70	1.9342	0.380	1350	Median n=26	596 13	1,337 4	336 9	1.1880	0.552
1450	Median n=218	219 89	208 57	205 72	0.9032	0.637	1450	Median n=54	278 23	353 11	305 20	0.1344	0.935
1550	Median n=248	270 98	255 62	257 88	2.5808	0.275	1550	Median n=123	366 55	317 27	321 41	0.0715	0.965
1650	Median n=269	262 106	253 64	266 99	1.5240	0.467	1650	Median n=159	317 72	366 33	369 54	0.3203	0.852
1750	Median n=279	359 107	356 68	359 104	0.9774	0.613	1750	Median n=174	446 73	475 40	494 61	0.0301	0.985
1800	Median n=287	410 113	406 69	419 105	0.4190	0.811	1800	Median n=184	479 75	533 44	502 65	0.4990	0.779

Obs=1498, observation unit: community. All communities in the dataset for each selected year are considered.

Obs=720, observation unit: community. We consider all communities in the dataset that adopt a formal institution in each selected year.

*Note.* The panel resource type on the first line of each year displays the median population estimate, while the second displays the number of observations in communities where pasture is prevalent, forest is prevalent, or having mixed resources. The second panel displays the  $\chi^2$  value of a test of equality of medians and the p-value, both continuity corrected. For ease of reading, when the median population is not an integer, only the integer is reported; tests are carried out on the original statistic.

The discussion begins with some assumptions and provides an overview of the indirect impact of economies of scale on group size.

Consider a production function where output is a function of capital and labor (Douglas, 1976). Community population data are taken as a measure of the labor force employed in production, and the land resource endowment of communities is taken as capital. Returns to scale can be evaluated only considering (a) the simultaneous change in the quantity of the inputs over time and (b) the difference in resource production depending on the type of each resource. Output and returns on scale remain unobserved in our dataset. Hence, the resource specificity argument cannot be tested directly. Can the question of whether the observed size of the group is affected by resource specificity be tested indirectly? Two examples are considered below to explore this question.

*Example.* Let us consider two communities: A=50 individuals and 1 hectare of commons, and B=100 individuals and 2 hectares of commons of the same type (i.e., forest). Economic theory predicts that if returns to scale are increasing (Douglas, 1976), the output in B is higher than in A.<sup>84</sup>

If it is assumed that returns to scale in production are increasing, the resource specificity argument would be consistent with communities with formal institutions having a larger size than communities under an informal regime.

*Example.* Let two communities, C (endowed only with forest, F) and D (endowed only with pasture, P), be of size  $n$ , so that  $n_C: F_C > 0, P_C = 0$  and  $n_D: F_D = 0, P_D > 0$ .

If there exists a difference in size between communities with only forest (type C) versus communities with only pasture (type D), the resource specificity argument

---

<sup>84</sup> With decreasing return on scale, it should have been lower; with constant returns to scale, the output in A is equal to the output in B.

is confirmed. If the converse pertains, the resource specificity argument would lose explanatory power, and a further explanation should be found.

Using the reduced panel, the null hypothesis of equality of the two medians in the two types (with prevalence of pasture and with prevalence of forest) of communities in all the selected years (1350–1800) was tested. The resource endowments of each community were broken down in single components. Many communities start their “documentary” existence only later in the dataset: these surfaces are referred to as surfaces represented by the documents. To have an idea of the resource covered in the dataset for each considered year, it is necessary to add the resource endowments of each one-layer community and of each two-layer community in the dataset. The total surface in each year is equal to the sum of each resource type in each community existing in the considered year. In this study, commons are considered half of the surface devoted to meadow,<sup>85</sup> grazing land, alp, and forest. Commons surface is, therefore, the total surface obtained by adding up each resource.

It was necessary to determine empirically which communities had prevalence of forest, which a prevalence of pasture, and a third set covering all other communities having a mix of resources and scarce commons. The ratio between forest (F) and pasture (P) surface in a community was first considered, and communities were divided in three categories according to the magnitude of the forest/pasture ratio. It is then necessary to separate communities with large commons from communities with scarce commons. If a community is defined as composed of two types of land (common and private), the size of common land (F + P) relative to private land (T) must be considered. Thus, a scalar  $k$ , arbitrarily set at  $k=10$ , is used to underline empirically the different productivity of private land versus common land.

---

<sup>85</sup> This is an arbitrary convention that was adopted, because meadows had a mixed management regime, half private and half commons.

Communities in 1800 were analyzed and divided in the following three categories according to “resource type”: (a) “pasture-prevalent,” (b) “forest-prevalent,” and (c) a residual category entitled “mixed resources.” The forest-prevalent category is characterized by a forest-to-pasture ratio greater than 3:1 and by a commons-to-private land ratio at least equal to 5:1. The pasture-prevalent category is characterized by a forest-to-pasture ratio lower than 2:1 and by a commons-to-private land ratio at least equal to 5:1. Communities with a mix of forest vs. pasture and endowed with scarce commons are placed in the residual category and disregarded when testing the equality of medians. The same categorizations were replicated in each of the selected years (1350–1800).

The results of the test are reported in Table 5.1. The test in all the cases failed to reject the null hypothesis that the median size of communities is equal in the two groups, forest-prevalent and pasture-prevalent. The medians of the two groups are very similar. The present authors consider this sound evidence that economies of scale were not a major factor in the determination of group size in collective action. Hence, group size was not resource-specific.

**5.3.2. Test of the free-riding argument.** Also large groups were successful, although using different “institutional technologies.” The collective action in harvesting the common resources (appropriation) is considered in analyzing this argument. If the free-riding argument is relevant, under an unregulated regime of appropriation on the common land, the surplus per capita should decrease as group size increases until its complete dissipation. Consider a group of  $N$  agents who harvest a common resource of fixed size exploited at the optimal level. In natural resource management economics, the maximum sustainable yield (MSY) defines the condition where the amount that is extracted from the stock of the resource is equal to the

growth of the resource in the same time unit. Under the MSY, the aggregate surplus,  $\pi$ , is maximized.<sup>86</sup> The optimal extraction level is the optimal level of aggregate surplus  $\pi^*$  extracted from the resource from the  $N$  interacting agents and is defined as a Nash equilibrium (Clark, 1990; Gordon, 1954). The strategy of the group of  $N$  agents is to keep  $\pi^*$  constant. If  $\pi$  is considered as a function of  $N$ , it is understood that, when keeping  $\pi^*$  constant, the (individual and) aggregate surplus in Nash equilibrium  $\pi^*/N$  decreases as  $N$  increases.<sup>87</sup> Therefore, the main prediction of this model applying the free-riding argument is that keeping a small group size helps in limiting the tragedy of the commons.

In this simple model, under formal institutions the surplus per capita should remain constant as group size increases.<sup>88</sup> The group of  $N$  agents obtains a higher aggregate surplus when small and informal interaction might be the solution that allows a higher rent level. When a group decides to adopt a formal institution, there is no size limit in the number of agents to maintain the aggregate benefits at the optimal level. The free-riding argument in the Olsonian formulation does not make any quantitative predictions about an optimal group size. Creating a formal institution is a type of collective action that should be easily solved only in small groups where there is no actual need of formal institutions. This conjecture cannot be tested directly, given the lack of sufficient historical data to provide reliable estimates of aggregate surpluses in the considered dates.<sup>89</sup> However, it can be tested indirectly using data from population size in formal institutions<sup>90</sup>, in the context of collective action for

---

<sup>86</sup> This concept is based on biological growth, which differs for each type of resource.

<sup>87</sup> Figure 5.1, curve [1], Appendix C.

<sup>88</sup> Figure 5.1, curve [2], Appendix C.

<sup>89</sup> i.e., the model in curve [1] in Figure 5.1, Appendix C cannot be tested empirically. Variation in per capita rents for a set of communities for a reasonable time period should be observed in order to make tests, and unfortunately, these data are not available. Particularly, to confirm the conjecture, as group size increases, per capita rents should decrease.

<sup>90</sup> Curve [2] in Figure 5.1 is tested.

creating and sustaining institutions for the management of the commons (participation).

If the free-riding argument is relevant, small communities should be found to be more successful in adopting formal institutions for collective action than large communities. After having divided communities into two categories, with informal and formal institutions, the median population of communities in each of the selected dates from 1350 through 1800 was analyzed. The descriptive statistics were illustrated and a rank-sum test of whether the medians were equal in the two categories in the same year performed. It was found that the free-riding argument alone does not explain the empirical evidence.

The group size effect was defined as the phenomenon of group size, with changes from  $n$  to  $m > n$  in correspondence with institutional changes from informal to formal institutions. In each of the selected dates (1300–1800), it was observed that the median population of the communities that do not adopt a charter is almost half that of communities adopting a charter. This evidence confirms that adopting a formal institution can be a way to solve collective action problems. In the change from informal to formal institutions, group size can increase. Hence, large groups can be successful (Henrich et al., 2005; Olson, 1965; Ostrom, 1990).

The results of a Wilcoxon rank sum (Mann–Whitney) test performed in all the selected years show that the distributions of the population estimates in informal and formal institutions were different with statistical certainty.<sup>91</sup> A median test confirmed the first result: that the median population size of communities under informal institutions is lower than that of those under formal institutions with statistical

---

<sup>91</sup> For 1350,  $n=193$ ,  $z=-4.85$ ,  $\text{Prob}>|z|=0.00$ ; 1450,  $n=213$ ,  $z=-3.95$ ,  $\text{Prob}>|z|=0.00$ ; 1550,  $n=244$ ,  $z=-4.82$ ,  $\text{Prob}>|z|=0.00$ ; 1650,  $n=264$ ,  $z=-5.21$ ,  $\text{Prob}>|z|=0.00$ ; 1750,  $n=275$ ,  $z=-5.06$ ,  $\text{Prob}>|z|=0.00$ ; 1800,  $n=283$ ,  $z=-4.59$ ,  $\text{Prob}>|z|=0.00$ .



certainty in all the selected years apart from the years 1450 and 1550.<sup>92</sup> In this test, the probability that a community randomly drawn from the communities under informal institutions is larger than a community randomly drawn from those under is estimated to be 0.374.

Outliers in population were excluded in some analyses.<sup>93</sup> Among the communities under informal institutions (n=778), there were 157 outliers, and under formal institutions (n=720), 107 outliers.<sup>94</sup> A closer analysis revealed that outside values are two-layer communities (super communities) or larger towns like Riva, Pergine, Rovereto, Brentonico, Avio, Borgo Valsugana, and others. All outliers were kept in the remaining analyses, as all existent communities were recorded either as independent entities or as included within a super community. The fact they are considered outliers the identification algorithm is not a sufficient reason to drop them from the analyses; it was decided to keep them, as their presence facilitated study of the organization of collective action with a higher degree of historical accuracy. Note that in this case, the mean and the variance are not suitable measures of centrality and dispersion of the data, and it is contended that using non-parametric methods is preferable. Medians and quartiles are considered more robust predictors of centrality and dispersion.

Because only changes from informal to formal institutions were recorded and there was a trend of population growth, one may suspect that the relationship between institutional change and group size increase is affected by population growth.

---

<sup>92</sup> For 1350, n=193, Pearson  $\chi^2=10.54$ , Prob>|z|=0.00 (continuity corrected); 1450, n=213, Pearson  $\chi^2=9.68$ , Prob>|z|=0.00 (continuity corrected); 1550, n=244, Pearson  $\chi^2=11.95$ , Prob>|z|=0.00 (continuity corrected); 1650, n=264, Pearson  $\chi^2=16.09$ , Prob>|z|=0.00 (continuity corrected); 1750, n=275, Pearson  $\chi^2=20.90$ , Prob>|z|=0.00 (continuity corrected); 1800, n=283, Pearson  $\chi^2=19.55$ , Prob>|z|=0.00 (continuity corrected).

<sup>93</sup> Figure 5.2, Appendix C; Table 5.2, Appendix D, for a tabular form.

<sup>94</sup> Outliers have been identified using a “blocked adaptive computationally-efficient outlier nominators” (BACON) algorithm (Billor, Hadi, & Velleman, 2000) for each of the selected years, setting the cut-off level at a significance level of p=0.15.

According to this criticism, the group size effect is produced by population growth and is not related to institutional change.<sup>95</sup> Therefore, seeking an explanation for group size effects in collective action mechanisms would be pointless. Both empirical and theoretical arguments are put forward to support the results.

Theoretically, population growth does not solve collective action problems. Indeed, according to the free-riding argument of collective action (Olson, 1965), as group size increases, collective action problems worsen. Moreover, at the community level, population growth is subject to countless negative shocks—pestilences, war, famine, and other factors—which give rise to population fluctuations. The regional population growth in the period was not always increasing. For instance, population decreased between 1350 and 1450. Population estimates were produced for communities at the exact year of first charter adoption (n=230), covering the period 1200–1800. The populations of communities in the exact year of the first charter adoption were considered. The empirical distribution of population size was highly asymmetric; thus, the observations were divided into 10 classes.<sup>96</sup>

The first six classes were defined to cover gaps of 150 individuals. Classes 7 and 8 cover an interval of 300 individuals; Class 9 covers an interval of 500 individuals, and Class 10 is residual: the empirical distribution is highly asymmetric. As the median community size increased, the year of first adoption decreased. Large communities adopted a charter earlier than smaller communities.

A visual inspection<sup>97</sup> showed a discontinuity between the medians of the median year of first charter adoption between population classes below 1200 (Classes 1–8; M=1428, n=24) and above 1200 inhabitants (Classes 9–10; M=1561, n=206). As the class size increased, the median year of charter adoption remained stable until

---

<sup>95</sup> As assumed at the beginning of this chapter; see Section 5.1 and Kremer, 1993

<sup>96</sup> Table 5.3, Appendix C.

<sup>97</sup> Figure 5.3, Appendix C.

1200 individuals was reached, and then dramatically dropped by more than a century after 1200 individuals. A rank-sum test was carried out on communities that adopted a charter before 1800, which identified two groups: 0=population above 1200, and 1=population below 1200. The test predicted that the distributions of the two groups would be different with statistical certainty ( $z=4.070$ ,  $p\text{-value}=0.000$ ). The median test provided a similar result but also showed that 19 communities above 1200 inhabitants had a first available charter earlier than the median year of the whole sample ( $n=24$ ) and that 109 communities below 1200 had the first available charter later than the median year of the whole sample ( $n=206$ ). The result was 0.06% significant (Pearson  $\chi^2=7.6122$ ,  $p=0.006$  (continuity corrected)).

No such discontinuity was detected between the group with observations from the first two population classes (population below 300 inhabitants) (Classes 1–2;  $M=1561$ ,  $n=123$ ) and the remaining observations (Classes 3–10;  $M=1533$ ,  $n=107$ ). The rank-sum test shows that the medians are not statistically different between the two treatment groups (0=population above 300 inhabitants; 1=population below 300 inhabitants) at any level lower than 95.48% ( $z=-0.057$ ,  $p=0.9548$ ). The result of the median test underlines that the majority of the communities with a population below 300 inhabitants adopted a charter later than the median year ( $n=65$  out of 123) and that communities with a population above 300 inhabitants adopted a charter earlier than the median year ( $n=58$  out of 107). Thus, this failed to substantiate a rejection of the null hypothesis that there is no difference between the two median years of charter adoption (Pearson  $\chi^2=0.8735$ ,  $p=0.350$  (continuity corrected)).

After these analyses, the exact relation between group size and adoption of a formal institution remains unclear. For instance, there could be a linearly increasing probability in group size, or there could be a threshold size.

**5.3.3. Test of the transaction costs argument.** There are differences in group sizes attributable to transaction costs. The transaction costs argument is based on the assumption that, if an alternative property rights arrangement exists to cope with positive transaction costs, the group will choose the alternative that guarantees the highest rent from collective action in harvesting the commons. Accordingly, if transaction costs increase with group size, large groups will adopt the institutional arrangement that will ensure the highest level of total rent and the net of transaction costs between the available alternatives. In the present case, when the group size increases, it will choose the regime that allows it to keep the level of total rents constant at the optimal level, which is flat. This is consistent with the second assumption made above. If true, the formal regime—besides an initial setup cost—allows a better management of transaction cost.

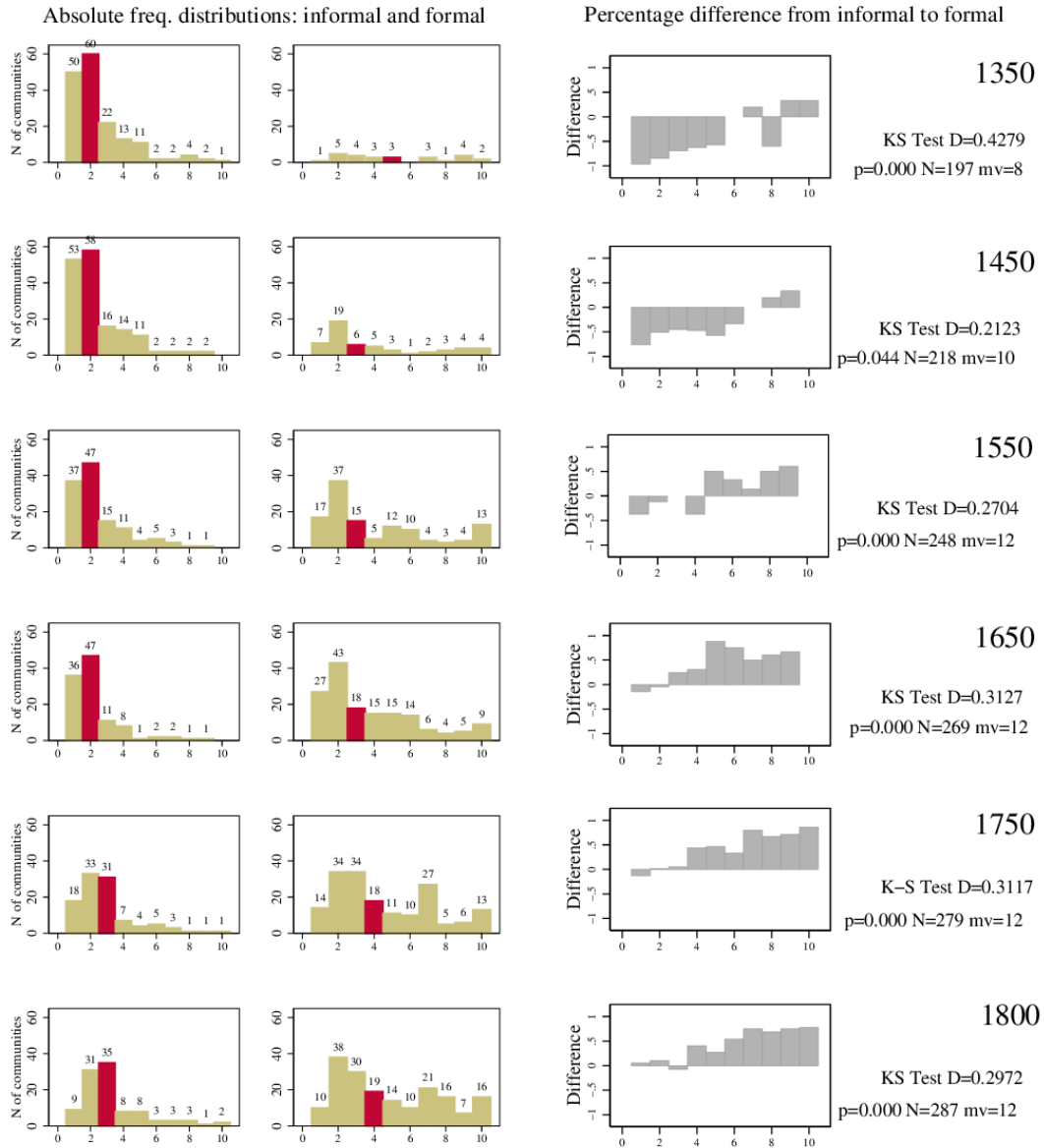
The present analysis concentrated on the choice between informal and formal institutions for collective action on harvesting the commons and observed where group size was largest. From the empirical side, group size is considered in the population data and proceeds through two steps. First, the increase in group size was considered in the change from informal to formal institutions as a first index of charter adoption and a strategy to cope with increasing transaction costs. It was initially observed whether such an increase occurred in each of the selected years. Second, it was tested whether there were differences in group size under informal and formal regimes between communities with prevalence of forest and communities with prevalence of pasture.

In general, economies of scale in production may not explain institutional changes from informal to formal regimes so evidently.

*Example.* Assume that the costs of creating a formal institution are fixed (i.e., invariant with the size of the group): adopting a rural charter costs  $L=100$ , and let two communities,  $x$  and  $y$ , be of size 150 and 300, respectively, so that the costs of adopting a formal institution are  $L_x=L_y=100$ .

If the transaction costs argument is true, group size should be smaller in communities where transaction costs on the commons are highest and larger in communities where these costs are lowest. Hence, to confirm the resource specificity argument, a statistically different group size would be required in communities with prevalence of resources having different productivity. To confirm the transaction costs argument, a statistically different group size is instead required in communities adopting different institutional arrangements to manage resources where transaction cost structure is different.

Figure 5.4. Group size and institutional change (1350–1800).



*Note.* On the left: the dark bar includes the community with the median population under informal and formal institution. On the right: the chart represents the relative difference (%) in frequency in each class. In each chart, the x axis plots 10 bins representing group size classes described in text. Below the year of the charts, the D from combined Kolmogorov Smirnov test, the exact p-value, and other relevant statistics are reported.

Is group size higher under informal or formal institutions? In Figure 5.4, the panel tests on the left visually display for each year that the majority of communities under informal institutions have a median population between 150–300 individuals (300–450 in 1750 and 1800) and that communities under formal institutions have a population in the upper population class (they have a median at least 150 individuals larger). The dark bar contains the median population estimate. The panel on the right portrays for each of the selected years (1350–1800) the relative differences in frequencies for each population size class.

Each community in each year is captured once in one of the two frequency distributions, either under informal institutions or under formal institutions.  $F(x)$  is the frequency distribution of communities under informal institutions, and  $G(x)$  is the frequency distribution of communities under formal institutions. Cases where no change occurred, where  $F(x)=0$  and  $G(x)>0$ , were removed from the chart. This was interpreted as  $F(x)=G(x)=0$  and graphically with a blank bar. Blank bars occur in Class 6 in 1350, Class 10 in 1450, Class 10 in 1550, and Class 10 in 1650. The blank bars in Class 7 in 1450 and Class 5 in 1550 are due to  $F(x)=G(x)$ .  $G(x)_k - F(x)_k$  is defined as the absolute difference in frequencies for the  $k$ -th class and  $[G(x)_k - F(x)_k]/N(x)_k$  as the relative difference in frequencies for the  $k$ -th class.

At a visual inspection, it is immediately clear that as the population size class increases, the formal solution becomes more preferred, particularly by large communities. The number of communities that choose a formal institution increases with the increase of the size class within the same year. The number of communities that choose a formal institution increases within the same class through time, until, in 1800, the preference for formal institutions is clear in each class, but with an increasing trend from lower-size classes to higher-size classes. Using the

Kolmogorov–Smirnov test<sup>98</sup> in each of the selected years, it was tested whether the two distributions of population size classes are statistically different. The first hypothesis tested asserts that the frequency distributions of the informal institutions group contain observations belonging to a population size class lower than for those in the formal institutions group. The result is always a positive  $D$ , significant at the 1% level in all the years except 1450, where the result is significant at the 5% level. The second hypothesis asserts that the frequency distributions of the informal institutions group contains observations belonging to a population size class higher than for those in the formal institutions group. The result is always a null  $D$  and always 1% significant. This means that the population of communities under formal institutions is always statistically higher than that of communities under formal institutions. Figure 5.4 shows the two main parameters of the result from the combination of two tests.

Is group size related to different transaction costs in different resource environments? To evaluate the effects of the change from informal to formal institutions in communities with prevalence of forest and with prevalence of pasture, it is necessary to observe the medians and perform a median test and estimate the probability  $P$  that the population of a community randomly drawn from the informal institutions group is higher than the one of a community randomly drawn from the formal institutions group.<sup>99</sup>

When considering the difference between the median of population size in the two groups, forest-prevalent and pasture-prevalent, in the change from informal to formal institutions, it is found that, regardless of the composition of the resource

---

<sup>98</sup> The test indicates with  $D$  the largest difference between the distribution functions in the direction considered by the two tests, either  $D^+ = \max_x \{F(x) - G(x)\}$  or  $D^- = \min_x \{F(x) - G(x)\}$ , and the combined test combines the results of the two tests  $D = \max \{ |D^+|, |D^-| \}$ .

<sup>99</sup> Statistics and results of the tests are reported in Table 5.4, Appendix D.



portfolio, communities under formal institutions have a significantly higher population and that the difference in absolute terms is not huge. The difference in population from informal to formal was tested using a rank-sum test, which confirmed almost always an institutional specificity such that the median populations in the two groups (informal and formal) are not statistically different at any level smaller than 10%. This effect is remarkable in communities where forest is prevalent. The estimated probability (P) is generally lower in communities where forest is prevalent. This effect is attributed to the different transaction costs in the two resources. The cost of securing property rights and collecting information in forest is much higher than in pasture, where mutual monitoring is easier using eyesight. Moreover, trespassing on resource harvesting limitation in the forest is even easier during nighttime, when monitoring is difficult. Additionally, damages on forest areas due to over-exploitation have effects for decades due to the slow renewal rate of the resource, while trespassing on pasture surely has a lower impact (yearly production, limited in milder seasons and at altitudes when there is no snow and ice).

This result was cross-checked with a similar analysis conducted on a remoteness index. Remoteness is measured as linear distance in kilometers from the closest local town: communities that are more isolated have a distance from the local town above the sample median. The intuition is that more isolated communities may have a higher transaction cost structure than that of less isolated communities. The difference in transaction costs was due to the increased costs of collecting information about the environment and others' behavior (monitoring costs) in more remote communities.<sup>100</sup>

---

<sup>100</sup> Assuming that a villager could walk on average 4 kilometers per hour, working more than 6 kilometers from the village would have meant more than 3 hours of walking every day, or even less (distance for the time requirement) if carrying a cart or weights on bumpy pathways.

*Example.* Let two communities,  $A=B=100$  inhabitants, be endowed with identical resource endowments  $x=y=200$  hectares of commons but be far from the closest local town ( $A=6$  kilometers and  $B=12$  kilometers). When group size increases such that  $A=B=200$ , in less isolated communities, it is easier to collect information about others' behavior. In addition, mutual monitoring by neighboring communities is more stringent.

Outsiders coming from neighboring communities are better recognized in the commons in less isolated communities, where the individual cost of monitoring is lower than in more isolated communities, where cheating on neighbors is easier because monitoring may require an ad-hoc activity. More isolated communities are defined here as communities being more than six linear kilometers away from the closest local town (the median distance of all the communities in 1800). Less isolated communities are less than six linear kilometers away from the closest local town. The median scores were calculated for more isolated and less isolated communities under informal and formal institutions, a median test was performed, and the probability that a community randomly drawn from the informal institutions sample has a larger population than a randomly drawn community from the formal institutions set was estimated.<sup>101</sup>

Field evidence is compatible with the present authors' intuition that more remote communities always have a lower median size than less remote communities do; however, this difference is not large enough to indicate a fundamental role for remoteness in the determination of group size in collective action. The interesting result is that a statistically significant increase in group size is found when communities, regardless of isolation, adopt a formal institution from the informal

---

<sup>101</sup> Results are reported in Table 5.5, Appendix D.

status.

The transaction costs argument in the two specifications identified, resource-specific transaction costs and remoteness-specific transaction costs, supports the regularities found in the field evidence. First, the median population is usually lower where forest is prevalent and when communities are more isolated, though this difference is not huge. Second, the difference in population size in the change from informal to formal institution is larger (and statistically significant) in communities where forest is prevalent, regardless of isolation.

Table 5.6.

*Assembly quorums found in documents*

Quorum	Frequency	Percent	Median Size
1/4	1	0.98	–
1/2	5	4.9	25
2/3	64	62.75	30
3/4	8	7.84	27
4/5	4	3.92	40.5
8/9	1	0.98	23
Unanimity	19	18.63	18
<i>Total</i>	<i>102</i>	<i>100</i>	<i>26.5</i>

*Note.* n=102. The quorum reported are those found directly in historical sources, with and without a list of attendants or any reference to attendants of any type. As can be seen, the most preferred are super-majorities, which count more than the 95% of the total quorums found. The number of observations having an estimate for assembly size (attending members + attending non-members) is 92. Source: Author's estimates.

**5.3.4. Test of the heterogeneous preferences argument.** Large groups approve collective contracts with lower deliberative quorums. In the next two arguments, on the focus is the size of the insiders group in participation and appropriation under the formal regime. The heterogeneous preferences argument posits that there is a tendency for the group involved in face-to-face interaction to

remain small to cope with heterogeneous preferences and to avoid cyclical voting: larger groups are likely to be heterogeneous. The heterogeneous preferences argument tackles the second collective action of interest for this study: participation in the creation and the management of institutions for collective action. Participation entails that the decision-making about the use of the commons is made by the restricted group of insiders, regulating beforehand the number of potential coordinating individuals in the commons and the consequences for trespassing through a sanctioning system toward outsiders but also toward insiders.

The focus is on collective decision-making when a formal institution is adopted. Attendance to community assemblies is considered. When, during the assembly, all participants are asked to intervene and cast a vote, the probability of a deadlock in the collective choice increases dramatically, and decisions are likely to be unstable due to cyclical voting. It is more likely for a small group to decide quickly and unanimously than it is for a larger one. As group size increases, more time and effort is required to reach consensus due to the increased costs of interaction among participants caused by the substantial time for collecting and processing individual preferences, when preferences are heterogeneous. According to the heterogeneous preferences argument, therefore, larger groups should have lower constitutive quorums, while small communities should have higher constitutive quorums. This hypothesis is moderately supported by the field evidence.

Analyses are performed on group size using the insiders data concerning community assemblies, and attendance is described by dividing mentioned individuals into three classes: (a) active members (i.e., community members who effectively attend the meeting and have “voice”– the right to cast a vote), (b) non-active members (i.e., members who are not attending and, therefore, inactive in the collective

decision), and (c) non-members attending the meeting with particular functions (witnesses, notaries, priests, officers, etc.).<sup>102</sup>

The number of active members can be a good proxy for the number of direct interactants in a meeting; this sample was focused on to study participation in institutions for collective action. Evidence about participation was found in a set of documents reporting quorums of attendance (n=94 docs from 1336–1796), comprising 10.8% of the total. In Table 5.6, the raw quorums found in the documents are summarized. A subset of 92 of these documents reports the list of active members. Upon visual inspection, the “2/3” (n=64) and the “unanimity” (n=19) rules are widely used (together, in 81.3% of the cases): this indicates a situation in which preference aggregation for the group decision is easy. Active membership is focused on. If the heterogeneous preferences argument holds, it should be possible to observe a higher quorum in assemblies having a smaller size in terms of active members. This choice indicates that reaching a collective consensus in a smaller group is easier.<sup>103</sup> It is tested whether there is a difference in active membership size between assemblies having a high constitutive quorum and assemblies having a low constitutive quorum. The threshold is fixed in quorums equal to unanimity or “below unanimity” rules.

The heterogeneous preferences argument is supported by field evidence. The test results of equality of medians returns a  $\chi^2=4.7639$  and a p-value=0.029 (both continuity corrected, n=84). The Wilcoxon rank-sum (Mann–Whitney) confirms these results (z=2.743, p-value=0.0061, n=84). A randomly drawn assembly where there is a quorum lower than unanimity has a probability of 0.748 of having a higher number of attending active members than a randomly drawn assembly where the quorum is unanimity.

---

<sup>102</sup> Figure 5.5, Appendix C.

<sup>103</sup> Figure 5.6, Appendix C, offers a visual representation of the results of the estimates of active membership size and quorums.

**5.3.5. Test of the cognitive limits argument.** There existed a group size threshold in collective action. The social brain hypothesis concerns the collective action carried out by the group of community members (insiders) having direct interaction in harvesting the commons (appropriation). The hypothesis predicts that there is an upper bound to the number of contacts which a person is capable to handle with his memory. When individuals are involved in interaction for appropriating common-pool resources, the memory constraint makes the identification of neighbors, as well as keeping track of their behavior, “difficult.” This hypothesis may explain why collecting information about others’ behavior and the level of depletion of common resources is “expensive” for the human brain. When the upper bound is reached, institutions are built to meet this human cognitive limitation in collective action. The present subsection aims to investigate whether there is a threshold group size in direct interaction for appropriation on the commons repeated over the centuries, estimate this size, and compare the results with current literature in the behavioral sciences. The analysis is focused on communities adopting a charter for which there are details about community assemblies.

This subsection will introduce the basic evidence, evidence from simple regression analysis, show the compatibility of the results with previous studies, and highlight potential weaknesses of the result. A simulation is used to overcome criticisms to the results by replicating the research conditions of previous studies with the present data. The link between the estimated group size thresholds and institutional change is finally expounded with the aid of additional evidence.

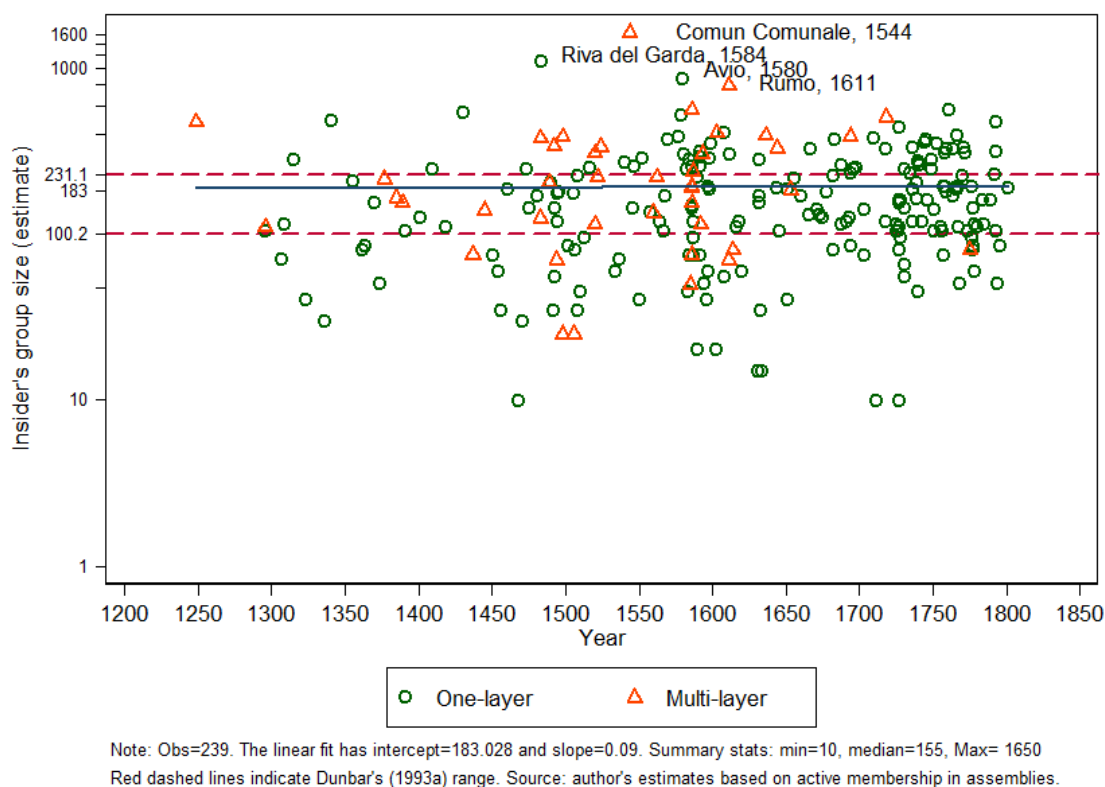
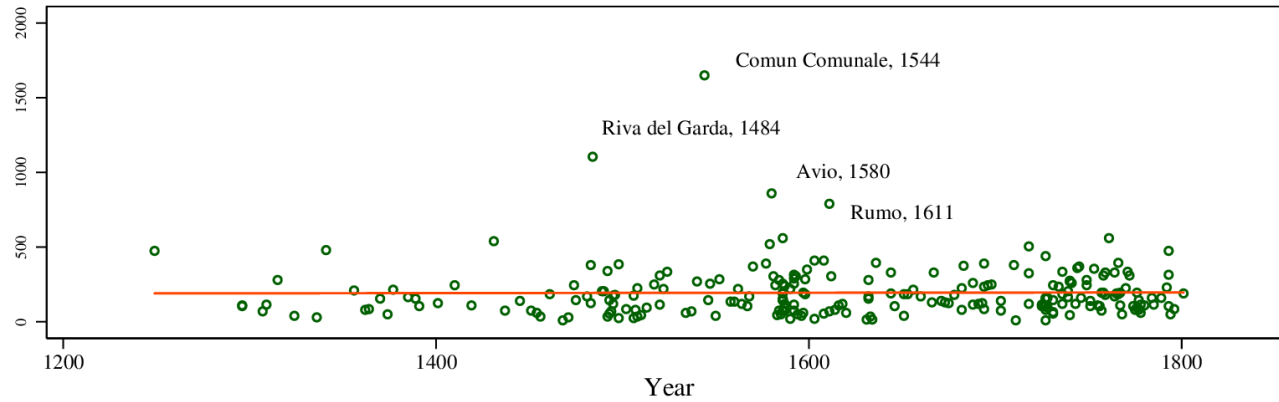
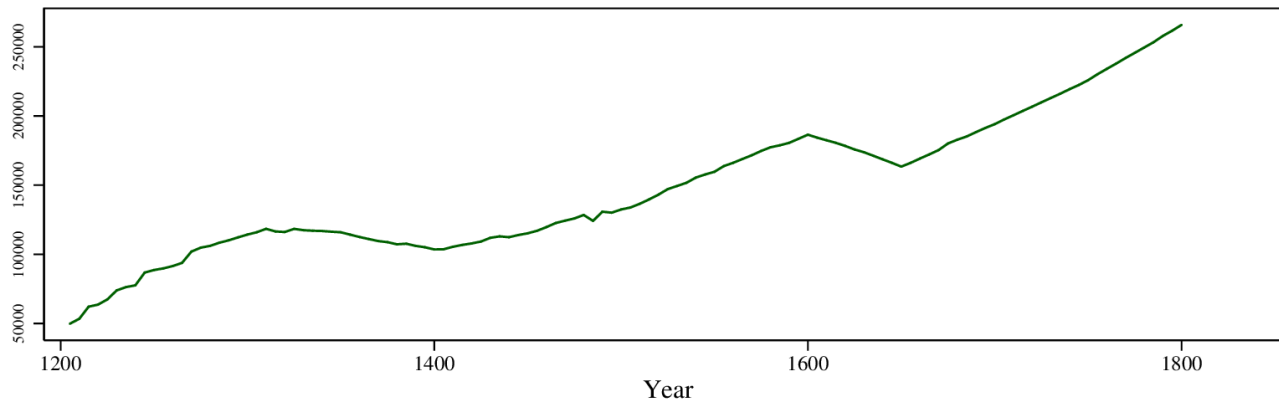


Figure 5.7.1. Number of appropriators (log-scaled) 1249–1801.

*Technical note.* Obtaining the number of appropriators for each village in multi-layered communities is conceptually and empirically problematic. The number of appropriators is an estimate based on community assemblies, valid at the community level and not at the village level. If estimates at the village level are desired, a village estimate might be computed either by a) dividing the community population for the number of villages of the multi-layered community or by b) computing the estimate for the number of appropriators in each village using the number of people coming from each village in each assembly. The problems with a) are that population is computed using sources different from assembly data and includes outsiders; in addition, if community population is divided by the number of villages, it is assumed that villages are equally sized; finally, even using the proportion of each village on the total community population in 1800 is not a good choice: outsiders would still be counted in, and the estimate would be not comparable with the appropriators' estimate of the single-layered villages. The problem with b) is that the estimate of appropriators would need to be applied with too restrictive assumptions: many assemblies do not report a quorum, and the pondered quorum of 0.73 would need to be applied, and if in assemblies there are members from more than one village, it would need to be assumed that there is the same proportion of appropriators from every village. Since collective action is being considered at the community level, unpacking the communities into villages is not desirable: this would mean treating every village in the multi-layered community as having a separate assembly. This is information not available at this stage of the research; however, a more detailed dataset is available in Chapter 6. In the present context, multi-layered and single-layered are pooled together and treated equally as units of observation for “collective action.”



Note. Number of appropriators on the commons: estimates for 1249–1801 (N=239), the linear fit has intercept=177.02 and slope=0.01. Source: documents



Note. Total population estimates of Trentino obtained by adding the population of all the communities in each year using Belletini (1987). Source: exppanel

Figure 5.8. Appropriators' group size vs. population (1249–1800).



*Basic evidence.* Summary statistics report a median size of 155 individuals for the full sample ( $N=239$ ) in which multi-layered communities are considered unpacked.<sup>104</sup> The median group size estimate is remarkably close to Dunbar's 147.8 individuals and in the predicted range. Under visual analysis, the size of the groups involved in collective action in the commons seems stable over time.

*Evidence from regressions.* Using the ordinary least square method (OLS) it was possible to determine an estimate of the average group of appropriators controlling for the effect of time.<sup>105</sup>

The first regression was carried out on the full sample of 239 observations for which it was possible to estimate the number of appropriators. The estimating equation was:

$$APPROPRIATORS_{all} = 183.028 + 0.009 \cdot YEAR \quad (5.1)$$

(124.134)      (0.074)

$$R^2 = 0.00; n = 239$$

Standard errors in Equation 5.1 are adjusted for 154 clusters representing communities. The coefficient of *YEAR* is not statistically significant at the 10% level ( $p=0.142$ ). Nonetheless, it is noteworthy that the coefficient is not different from zero at the 10% level ( $\text{Prob}>F=0.8956$ ). While the population of Trentino in the same period tripled, the number of appropriators remained stable throughout the period of observation (Figure 5.8). The simple linear regression could be more precise if it were possible to unpack multi-layered communities into estimates at the village level. A more accurate estimate could be obtained based on the number of appropriators in each village, while the current estimate represents the appropriators convened at the community level. In Figure 5.7.1, four particular cases are noticed: Comun Comunale

<sup>104</sup> Table 5.7, Appendix D.

<sup>105</sup> For a definition of appropriators, please refer to Appendix A. A description of the data is offered in Section 3.2.4. Technical details for estimation are reported in Figure 5.7.1.

and Rumo are particularly large conglomerates of communities, while Riva del Garda and Avio are exceptionally large communities. Cases where active members are from the village where the assembly takes place (single-layered communities) were separated visually from cases where active members come from different villages (multi-layered communities, 42 observations out of 239). Notice that some multi-layered communities had a small number of appropriators, and this evidence was meaningful for the way collective action was organized in communities. In single-layered communities, the village and the community are overlapping concepts, and active members are from the same village. In multi-layered communities, instead, active members may come from a village other than that in which the assembly takes place. This indicates that the assembly regulates institutional collective action on two levels: the single-village level and the assembly-of-single-villages level. It is also considered that not all the active members could attend, and in many cases, representatives of the villages are sent to the assembly. Therefore, the appropriators' group size is certainly an estimate of the number of individuals involved in the institutional collective action at the multi-layered level, but it cannot be used to estimate appropriators at the village level (Figure 5.7.1).

A second regression employed the subsample of single-layered communities. Coefficients are reported in Equation 5.2:

$$APPROPRIATORS_{single-layer} = 170.91 + 0.009 \cdot YEAR \quad (5.2)$$

(164.21)      (0.099)

$$R^2 = 0.00; n = 143$$

Standard errors were adjusted for 93 clusters representing communities. The communities in the sample were estimated to have on average 170 appropriators interacting face-to-face between 1245 and 1801. Again, the coefficient for year is statistically zero at the 10% level (Prob>F=0.9232): this means that there was no

significant time trend in the estimation of group size.

The analysis of the coefficients in both Equations 5.1 and 5.2 showed that the number of appropriators in formal institutions was stable over time. A reliable estimate of the average number of appropriators for the case of the *Carte Di Regola* is computed to be 183. This number is deemed to hold both for single-layered and multi-layered communities, as what is of interest is the number of face-to-face interactants. It is conjectured that large groups adapt to this cognitive limit by adopting a formal institution—for example, a system of village assemblies such as the *Carte Di Regola*—to allow interactions at a “cognitively sustainable” level and as a strategy to minimize transaction costs.

*Criticisms to the results.* However, it is borne in mind that Dunbar’s hypothesis concerns the mean value (147.8) but also the limited variance (100.2–231.1). One possible criticism of these results is that only a limited number of observations in our sample actually fall within Dunbar’s interval; namely, 43%.<sup>106</sup> This objection is answered first by underlining the differences between the present sample and Dunbar’s (a); as a second stage it is specified how the present methodology differs from the anthropologist’s (b); as a third stage the results of the two studies are compared (c); The present claim has been finally reinforced using a simulation.

(a) Differences in the treatment of the sample. As discussed in Section 4.6.3, Dunbar’s results are based on a best-fit reduced major axis regression. The cited author uses a best-fit reduced major axis regression between neocortex ratio and mean group size computed on a sample (N=36) of non-human primate genera. The dependent, group size  $N$ , and the correlate, the neocortex ratio  $C_r$ , are log-

---

<sup>106</sup> Thanks to Vincent Buskens for raising this point.

transformed. Using the inverse transformation, the anthropologist obtained the predicted 147.8 mean value and the 95% confidence interval (100.2–231.1) for humans, which turn out to be an “out of sample” prediction. Foreseeing that the results obtained were internally valid for the primates in the sample, Dunbar (1993a) reinforced the external validity of the finding by reporting abundant historical and anthropological evidence in support of his claim. Admittedly, the evidence is convincing and is confirmed also in later studies by the same author. Studies by other authors applied different methodologies.

(b) Differences in methodology. The present sample reports a result that is in line with Dunbar’s hypothesis but uses a larger sample ( $n=239$ ) of observations spanning over six centuries (1245–1801). In addition, while Dunbar (1993a) analyzes “mean group size” of “non-human primate genera,” the present study directly observes point estimates of human group size. The linear fit between the dependent *APPROPRIATORS* and the correlate *YEAR* is computed using heteroskedasticity-robust standard errors without operating transformations. Therefore, the estimating equations, as well as the variables used to compute the prediction and the results, are completely different.

(c) Comparing the results of the two studies. Apparently, the present result is even weaker than Dunbar’s: the coefficient before *YEAR* is not even significant, and the variance explained by the model is very close to null, while in Dunbar’s result, the variance explained by the model is 76.4% and the coefficient before the neocortex ratio  $\log(C_r)$  is 1% significant. For the external validity of the present result, the same literature quoted in Dunbar (1993a) and all the following studies reported in Section 4.6.3 were used for support. As to the internal validity of the result, it should be stressed that the present findings are based on a “within-sample” prediction based on

point estimates, while Dunbar refers to the mean group size in non-human primate genera. Dunbar (1993a), in his study (p. 682), referred his sources for neocortex size (Stephan, Frahm, & Baron, 1981) and group size (Dunbar, 1992; in particular, see his paper's Table 1, in which he refers to "Mean values from relevant chapters in Smuts, Cheney, Seyfarth, Wrangham, and Struhsaker (1987)" as the primary source for mean group size). The author, however, did not report how many non-human groups of primates (i.e., the sample sizes) were included in each of the 36 group size means used to obtain the predicted mean value of 147.8. The primary source was consulted for group size (Smuts et al., 1987): a closer look of, for instance, Tables 11-1 to 11-5 (pp. 123–128) shows that the original data draws estimates based on a variety of field studies. Group size estimates are referred to each species and are divided by country of observation, and for each country, there are details on the mean group size computed on a number of groups reported to vary from 1 to 85, depending on the level of aggregation. The question remains as to why Dunbar chose the mean group size and not the maximum for each genus. His answer is reported here:

The main justification for using mean group size in these analyses lies in the nature of primate social groups...primate groups tend to oscillate in size over quite a wide range around the optimal value. At the point of fission (by definition, their maximum observed size), groups tend to be unstable and close to social disintegration; this is of course why they undergo fission at that point. Hence, maximum group size is likely to represent the point of complete social collapse rather than the maximum group size that the animals can maintain as a cohesive social unit. Consequently, mean group size is likely to be a better estimate of the limiting group size for a species than the maximum ever

observed in any population. (Dunbar, 1993a, p. 682)<sup>107</sup>

This choice is well documented, and for the same reason indicators of centrality (the mean or the median) are chosen for the present analysis as well as throughout Chapter 6. However, there is a statistical caveat behind this choice that the reader must take into consideration: the mean value (147.8) and the limited variance (100.2-231.1) of Dunbar's results are based on "means of means" and not on direct estimates. This "mechanically" allows to control considerably the oscillation of the population variance and to obtain a more robust prediction. Why? Because of general statistical properties, an average of averages within a sample is said to very closely approximate the population average as the number of samples increases;<sup>108</sup> however, the same does not hold for the population variance.

*Overcoming the criticisms: a simulation.* A simulation was performed to replicate Dunbar's research setting in our dataset. The aim of the simulation is to show that the present results are in line with the anthropologist's on the methodological side, in order to strengthen their internal validity.

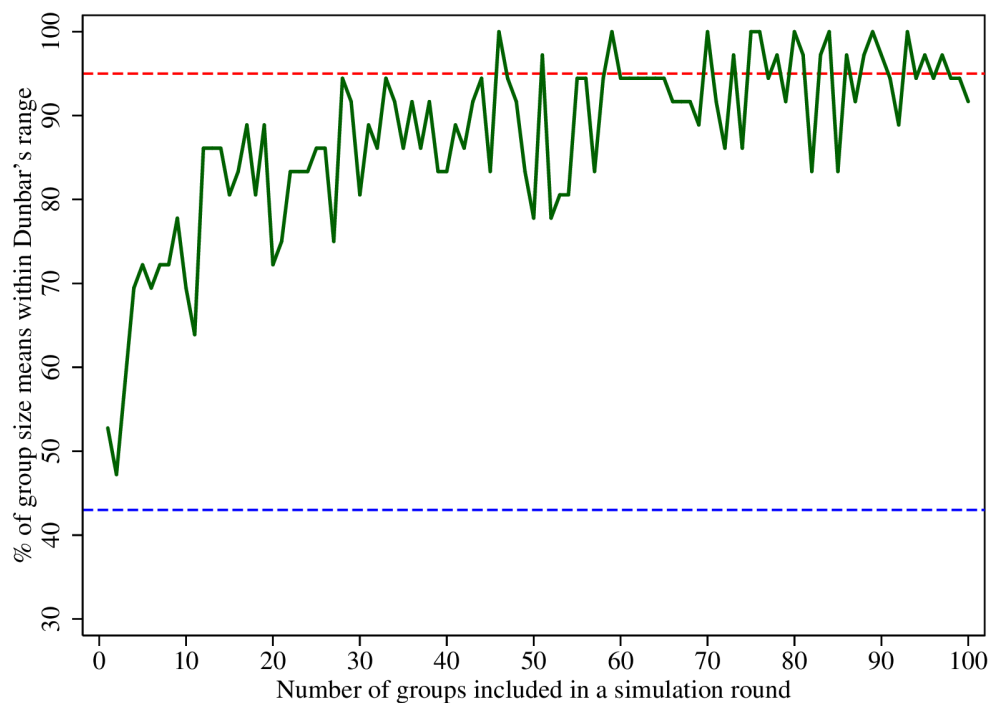
The claim tested is that if the present  $n=239$  observations are divided in  $z=36$  uniform classes (analogous to Dunbar's  $N=36$  "non-human primate genera") each containing a number of  $k$  groups sufficiently large, as  $k$  increases: (a) the mean of the  $z=36$  uniform classes (on their turn, means of the  $k$  groups) will tend to the population mean ( $M_n=198.60$ ,  $n=239$ ) as  $k$  increases, (b) the variance of the mean will be reduced dramatically as  $k$  increases. As a consequence, an increasing number of observations (this time, means of means) will fall within the 100.2–231.1 range.

---

<sup>107</sup> For further discussion, see Dunbar (1992a).

<sup>108</sup> The property mentioned is the well known "central limit theorem". According to the theorem, the distribution of an average tends to be normal, even when the distribution from which the average is computed is decidedly non-normal (e.g., a uniform distribution). For an animated test of the central limit theorem, please consult [http://www.statisticalengineering.com/central\\_limit\\_theorem.html](http://www.statisticalengineering.com/central_limit_theorem.html) (last visited: 12.3.2013).

The simulation is designed as follows. The  $n=239$  appropriators' group size estimates were pooled, and a routine that draws randomly from the pool  $k=\{1,2,\dots,100\}$  sets of  $j=\{1, 2, \dots,100\}$  observations (1 observation is 1 appropriator's group size estimate) for  $z=36$  times was programmed. The  $k=\{1, 2, \dots,100\}$  sets are defined as "simulation rounds." For each simulation round,  $z=36$  group size means are computed, and eventually the mean of the 36 means and the proportion of means falling into the 100.2–231.1 interval are computed.



*Figure 5.9.* Simulation of Dunbar's research setting using this study's data.

*Note.* The lower dashed line depicts the percentage of observations in the interval in the observed point-data on appropriators ( $N=239$ ), assumed constant. The upper dashed line shows that 95% of Dunbar's observations fall into the interval (95% confidence interval).

While the demonstration of part (a) and (b) of the claim is obvious on a statistical basis, the consequences on the inclusion of the means in the 100.2–231.1 range are surprising. In Figure 5.9, it is observed that the percentage of group size

means included in the range 100.2–231.1 reached 95% when the number of groups included in the simulation round reached 30.

Based on this simulation, it is apparent that the present results are now closer to Dunbar's. This methodology may also have helped the anthropologist to get such a high  $R^2$  and a “moderately wide” confidence interval. Consequently, the two studies report results that are compatible, even though the present study exhibits fewer observations in the same range. At the same time, the results should not be directly compared, because the methodologies differ as to data used and methodologies. Had the present observations been divided in groups and a mean group size for each group computed, the percentage of observations in Dunbar's range would have increased substantially, even reaching 100% if the number of groups these observations were divided into was sufficiently large.

In Mccarty, Killworth, Bernard, Johnsen, and Shelley (2001), a team of anthropologists, after performing seven surveys in the U.S., found that the average network size of respondents was 290 (s.d. 232, median 231), using different methods of counting and several robustness checks. The authors in some occasions affirmed that the number is not an “average of averages” but a “repeated finding” and “almost certainly not an artifact of the method,”<sup>109</sup> thus openly challenging the findings and the methodologies used in Dunbar (1992, 1993a). The number 290 is known among specialists as “Bernard–Killworth's number,” though it is less well known than the analogous Dunbar's number. There are two lessons to be learned from this. First, Dunbar's range can be an underestimate of the cognitive limit, defined as the number of people with whom one can maintain stable social relationships (and perhaps

---

<sup>109</sup> H. Russell Bernard. “Honoring Peter Killworth's contribution to social network theory.” Paper presented to the University of Southampton, 28 September 2006. Retrieved from <http://nersp.osg.ufl.edu/~ufruss/documents/killworth%20event%20sept%202006.ppt> (last visited: 20/3/2013).



methodologically biased). Second, other estimates of this limit refer to human social networks (Mccarty et al., 2001; Ugander, Karrer, Backstrom, & Marlow, 2011), with direct observation and different methodologies, and all report estimates appreciably higher than the upper-bound limit. What is relevant for the present case study is that the findings of these studies only serve to further support our claim, since higher estimates would only lead to including more observations in this range (Mccarty et al., 2001; Ugander et al., 2011). Therefore, the present estimate is considered as one peculiar of this case study, although in line with the findings of Dunbar (1992, 1993a), Ugander et al. (2011), and Mccarty et al. (2001).

*Linking the estimated thresholds to institutional change.* A last set of tests have been carried out to understand whether or not the linear predictions of 183 (if the full sample is considered, which includes also multi-layered communities) or 170 (if only single-layered communities are considered) appropriators, the mean group size of 198.8 individuals or the median of 155—all included in Dunbar's range—identify thresholds for institutional change. The evidence appears to strongly support the cognitive limits argument, and these reasons are contained in two additional tests performed on informal institutions. The argument is backed by additional evidence articulated in three stages: (1) reasons for using the villages' size under informal institutions as informative for subsequent analyses, (2) estimation of “comfort” and “tolerance” zones, (3) robustness checks.

(1) Indirect evidence from informal institutions. Little can be said about informal institutions without direct observation: knowledge is limited to the existence of villages and multi-villages, their estimated population, and the year of their transition to a formal institution. What is known, for instance, is whether they had informal gatherings for coordinating their action, or whether they simply harvested on

the commons. The present study also does not observe—as also in formal institutions—the proportion of outsiders on the total population. It was considered that in informal institutions, the proportion of outsiders was reasonably low. If one of the purposes of adopting a formal institution was to define the number of legal users (thus, the distinction between insiders and outsiders), one can assume that in informal institutions, outsiders were not problematic for the management of the commons. Thus, the population of communities under informal institutions can be considered a proxy for the number of appropriators on the commons.

(2) Estimation of the “comfort” and “tolerance” zones. Based on the available information, the single-layered communities under informal institutions ( $n=778$ ) were selected from the reduced panel. The median population size of this sample is 231 (IQR=253). Incidentally, this value is equal to Dunbar’s upper limit in the 95% confidence interval. The way in which the observed year is correlated with population was analyzed using the following linear regression estimation:

$$POPULATION = 13.048 + 0.20 \cdot YEAR \quad (5.3)$$

(116.73)    (0.074)\*\*\*

$$R^2 = 0.00; n = 778$$

The population of informal communities seems to remain stable over time, and the coefficient of *YEAR* is statistically significant at the 1% level. Visually,<sup>110</sup> the linear fit is just above 231 (the median, or Dunbar’s upper bound of the 95% confidence limit). Only 36.8% of the observations are in Dunbar’s range, and when the medians for each of the six selected years are computed, four of these medians are below 231. The medians for the years 1750 and 1800 are above Dunbar’s upper bound and concern years of particular difficulty for the *Carte di Regola* regime.

Therefore, it can be considered that Dunbar’s upper bound value is also an

---

<sup>110</sup> Figure 5.10, Appendix C.

upper bound for informal institutions. A “comfort zone” can be defined below this value.

At this stage, it is not possible to state how much of the informal communities this upper bound meant for entry in a “zone of tolerance” in which, at any time, the transition to a formal regime was possible. Many of these villages transitioned to a formal regime. Following a similar reasoning, the free-riding hypothesis<sup>111</sup> and compatibly with economic theory (Kremer, 1993) were tested. It can be conjectured that if the upper bound exists, large communities transition to the formal regime by adopting the first *Carta* earlier than small ones do. Accordingly, from the documents dataset, the communities of which the number of appropriators during the first adoption of a *Carta* (n=71) can also be observed were selected, without excluding multi-village communities from the final sample. The community population in 1810 and the year of the adoption of the first charter (n=65) are first considered. The linear regression equation is:

$$POPULATION_{1810} = 3240.24 - 1.673 \cdot YEAR \quad (5.4)$$

(831.06)\*\*\*      (0.540)\*\*\*

$$R^2 = 0.13; n = 65$$

An increase of 100 years in the first adoption of a *Carta* is correlated with a decrease of 167 inhabitants of the community population (standard errors clustered for 65 communities). Thus, on average, larger communities in 1810 were the first to adopt a *Carta*.

(3) Robustness checks. As a robustness check, community population at the year of the adoption of the first *Carta* was considered. This allowed checking whether the result was consistent at the population size value closest to the upper bound. The result was substantially unchanged:

---

<sup>111</sup> Figure 5.3, Appendix C, using the main dataset.

$$POPULATION_{adoption} = 1285.44 - 0.575 \cdot YEAR \quad (5.5)$$

(477.84)\*\*      (0.310)\*

$$R^2 = 0.05; n = 65$$

It was also observed that, out of the 65 communities in the sample, 77% transitioned while having a size in the comfort zone (below Dunbar's upper bound), and 23% transitioned to a formal institution when having a size in the zone of tolerance.<sup>112</sup> In addition, the number of appropriators at the year of transition to a formal institution is stable over time; thus:

$$APPROPRIATORS_{all} = 15.74 + 0.096 \cdot YEAR \quad (5.6)$$

(153.98)      (0.100)

$$R^2 = 0.01; n = 71$$

$$APPROPRIATORS_{single-layer} = 170.04 - 0.003 \cdot YEAR \quad (5.7)$$

(192.14)      (0.120)

$$R^2 = 0.00; n = 57$$

Again, group size during the transition to a *Carte* regime in the full sample of appropriators' group estimates and in a subsample containing only single-layered communities was considered. The coefficient of *YEAR* was not significant but statistically not different from zero at the 10% level (Prob>F=0.7757 in Equation 5.6; Prob>F=0.9751 in Equation 5.7). Note that the predicted value of 170 in Equation 5.7 was remarkably similar to the one obtained with a larger sample in Equation 5.2. The median number of estimated appropriators on the commons was 142, while the mean was 163 (Dunbar's mean was 147.8). The basic result obtained from statistical analyses on historical data was that large communities are those who adopted a first *Carta* the earliest. This was interpreted as evidence that an upper bound in group size

---

<sup>112</sup> It is acknowledged that many factors could determine how wide the zone of tolerance was; that is, how long the informal community waits to grow before transiting to a formal regime. These investigations, however, fall outside the scope of this chapter.

does exist.

#### **5.4. Conclusions**

Much debate in recent decades has been devoted to understanding the role of group size in collective action and in institutions. This chapter contributes to this literature by identifying and testing five key factors that may explain the importance of group size for collective action in the commons. The analysis used the case study of hundreds of communities in the Italian Alps and their institutional changes from 1200–1800 using a variety of historical sources. The following were considered as potential predictors of institutional change: that group size may be resource specific, the free-riding logic, the transaction costs in delineating and enforcing property rights, the difficulties in aggregating individual preferences and in reaching a collective consensus, the human cognitive limits in social interaction, which eventually should reveal the existence of a critical threshold in group size.

In conclusion, it was found that group size matters in the choice between an informal and a formal institution. In communities adopting a formal institution, the median size is considerably larger than the median size of communities under informal institutions for the selected dates in 1350–1800. Among the communities that ever adopted a charter (n=230), the timing of charter adoption is related to community size. The larger the community, the earlier the adoption. Particularly, it was found that communities with a population above 1200 inhabitants have a median year of first charter adoption statistically lower than the other communities. On the whole, the free-riding argument is not supported by empirical evidence: Large groups are also able to solve collective action using formal institutions.

A small and not statistically significant difference was found between the median of population size in the forest-prevalent and pasture-prevalent groups in the

considered years. Overall, there is a slight resource specificity in group size, which may also be related to differences in transaction costs between the two different resources, and not necessarily to economies of scale in production. The conclusion for the case of the Trentino communities is that from 1350–1800 economies of scale are not a major factor in explaining the role of group size in collective action.

It was found that communities always increase in size in the change from informal to formal institutions. Over time, the formal solution is established as the most preferred by the vast majority of communities. The median population is almost always significantly higher under formal institutions than under informal institutions, but the difference, in absolute terms, is not large and is more significant in forest-prevalent communities. It was found that group size in the two types of resources is institution-specific, remarkably so in communities where forest is prevalent. This effect is attributed to the different transaction costs in the two resources: in fact, transaction costs are higher in forest. Remoteness was also considered in terms of linear distance from local town as another proxy to capture differences in transaction costs structure for the interaction on the commons. More isolated communities usually have a higher transaction cost structure than less isolated communities: if the transaction cost argument holds, more isolated communities are expected to be smaller in size and to increase their size when they adopt a formal institution. It was found that, overall, more isolated communities are smaller in size, even though the difference between those and less isolated communities is not huge. There was a statistically significant increase in size when a charter was adopted by the communities, regardless of their remoteness from the closest local town.

The heterogeneous preferences argument is moderately supported by field evidence. When comparing the median size of groups adopting a unanimity rule with

the median of groups using other quorums, the hypothesis of equality of medians (medians are not statistically different at any level below  $p < 0.05$ ) can be rejected. The hypothesis of equality of the distributions of the attendance of active members is also rejected ( $p < 0.01$ ). A randomly drawn assembly not adopting a quorum of unanimity has a probability of 0.748 to have a higher number of attending active members than a randomly drawn assembly where the quorum is unanimity.

Field evidence strongly supports the role of cognitive limits in explaining group size and institutional change. Notwithstanding population in the Trentino region tripled between 1250 and 1800,<sup>113</sup> group size in collective action in harvesting the commons remains in the order of hundreds for six centuries; particularly, the number of appropriators estimated using the data from assemblies points to a stable size over time.<sup>114</sup> In formal institutions, potential threshold values of 198 (if the mean is considered) or 155 (if the median is considered) appropriators were identified. The threshold is quantified in 183 (full sample, which includes multi-layered communities) or 170 (if only single-layered communities are considered) predicted appropriators in 1245–1801. The linear fit is stable throughout the observation period.

A simulation was performed to demonstrate how this result strongly supports the argument and how this result is also in line with Dunbar's hypothesis of a limit in the number of contacts with which the human brain is able to handle stable relationships. In groups governed by an informal institution, an upper bound cognitive limit was identified at 231 individuals (median), having a similar characteristic of stability over time. This result potentially explains the rationale of the transition to a formal institution if groups are transaction cost minimizers. What cannot be observed is the behavior of the group internal to the community once these thresholds have

---

<sup>113</sup> From 88,674 to 265,805 inhabitants; Figure 3.1, Appendix C.

<sup>114</sup> Figure 5.8, Appendix C.

been passed and the group finds itself in the zone of tolerance. However, in this case, what organization strategies are adopted by the group for collective action? This question is addressed in Chapter 6.



## Chapter 6: Group Fission and Fusion in Institutions

*You know that at the encounter of two Roman Legions I have taken two Battalions of six thousand infantry and three hundred cavalry effective for each Battalion, and I have divided them by companies, by arms, and names. You know that in organizing the army for marching and fighting, I have not made mention of other forces, but have only shown that in doubling the forces, nothing else had to be done but to double the orders (arrangements).—(Machiavelli, 2003, Book VI)*

### 6.1. Introduction

The present chapter studies the phenomenon of fission and fusion of face-to-face groups among ~200 villages in Trentino and traces their institutional changes in the long run. It also investigates the consequences of fission and fusion for the internal organization of groups. Two issues deriving from Chapter 5 suggest the opportunity of treating this topic. The first is theoretical, and concerns the existence of group organization strategies capable of minimizing transaction costs when group size increases beyond a threshold, regardless of the degree of formality of institutions. The second is empirical, and is based on the evidence that population in Trentino almost tripled during 1200-1800 while community population on average remained constant.

The general expectation is that communities in which group size increased above the threshold experienced fission events (or a restructuring of the internal organization of the group), regardless of time and keeping constant all other factors.

This chapter introduces the research question, presents previous studies that tackled similar phenomena, illustrates the data and analyses, and eventually presents an interpretation of the evidence using a simple economic model.

Based on the structured observation of case studies over the long run, this chapter claims that groups aiming at the optimal management of common lands not only face the choice between informal and formal institutions but may also intervene on the costs of institutional choice by deciding how to organize collective action within these institutional forms. The voluntary division of groups into two or more subgroups and the adoption of an internal structure to manage collective action is a recurrent phenomenon in the organization of the social life, and represents a solution of a “cost minimization problem”. There may be multiple methods to organize collective action in consequence of fission and fusion after the transition to formal institution and that the choice of these methods is dependent on group size.

To support this conjecture, this chapter reconstructs the dynamics of fission and fusion in communities composed of more than one village: the systematic observation of the fission and fusion behavior in these communities seeks compatibility with current theories, and mainly with the transaction-cost driven institutional change described in Sections 4.3–4.8. Specifically, empirical evidence is sought in support of the conjecture in the context of communities that have to decide how to allocate property rights on common land. This chapter finally tests whether fission and fusion are compatible with the existence of thresholds in group size.

The data and the analyses in this chapter are in line with previous findings in the literature about group size, network size, and hierarchical structures (Zhou et al., 2005) already described in Section 4.6.3. Anthropologists and biologists have long observed fission behavior in nature.<sup>115</sup> Group and network sizes are cognitively

---

<sup>115</sup> See Chapter 4.7 for a review. As discussed in Chapter 5, Dunbar (1993a, p. 682) justified the choice of the mean group size of primate groups to determine the existence of cognitive limits. Dunbar also remarked that, whereas other animals like birds or herbivores have relatively simple aggregations, primate groups are characterized by aggregations that are structured in complex sets of social and kinship networks. It can be observed that bird flocks split as they exceed their optimal size, while in primate groups, this point oscillates considerably: “At the point of fission [...], groups tend to be

limited, and internal structures are adopted to cope with such constraints (Dunbar, 1993a, 1998; Kosse, 1990; Kosse, 2001; Zhou et al., 2005). This process of unpacking the group size problem and then solving collective action has been identified by anthropologists and biologists by the name “fission–fusion dynamics,” which properly define the “extent of variation in spatial cohesion and individual membership in a group over time” (Aureli et al., 2008). The observation of fission–fusion behavior in institutions allows testing of the second part of the threshold hypothesis, reported in Section 4.8:

*Conjecture.* After crossing the threshold, large groups tend to structure their internal organization in smaller sub-groups.

Why do communities fission? The question that ignited the present research was whether there could be a connection between the observation of division and adoption of an internal organization of villages, what anthropologists and primatologists since long called fission–fusion behavior, and the threshold hypothesis.

One explanation is that the rationale behind this behavior, observed in multi-layered villages (fission) or in small villages (fusion), may be economic in its essence and, consequently, influence the institutional decisions of a group, eventually embodied in its legal documents. The social brain hypothesis posits the existence of fission–fusion behavior in relation to cognitive limits of the human brain, which is able to keep track of a limited number of contacts; this limitation is due to the existence of a relationship between the size of groups and the neocortex volume in primates and in humans (Dunbar, 1993a, 1998, 2003, 2009, 2012) and has found empirical support also by other scholars (Bickart et al., 2011).

---

unstable and close to social disintegration: this is why they undergo fission at that point.” (Dunbar, 1993a) The effectiveness of this principle has been observed in action in many human and non-human social settings, and it has been found to be a rather common and universal principle governing the engineering of nature.

Chapter 5 illustrated whether these human cognitive limits may affect the functioning of institutions for property rights, finding that group size may well be determined by transaction costs and by human cognitive limits, and concluding that these limits may also affect the structure of institutions. A series of studies claim that groups adopt an internal organization to coordinate relationships at a lower cost for information collection and dissemination. For instance, Zhou et al. (2005) find that:

The fact that these relationships are not simply a matter of memory for individuals but, rather, of integrating and managing information about the constantly changing relationships between individuals within a group, is indicated by the fact that relative neocortex size correlates with a number of core aspects of social behaviour and socialization in primates (Byrne 1995; Pawlowski et al. 1998; Joffe 1997; Lewis 2000; Byrne & Corp 2004). It has, however, always been recognized that both human and non-human primate groups are internally highly structured (e.g., Dunbar 1988). (Zhou et al., 2005)

Technically, fission–fusion strategies are both universal and “end neutral.”

They occur in non-human and human behavior as an effective problem-solving strategy. In the context of institutional analysis, the logic of fission–fusion behavior is susceptible to an economic interpretation: dividing a group can allow for efficient problem solving when meager resources are available. One reason is mechanical: a complex and apparently unsolvable problem is unpacked in smaller and simpler sub-problems. Eventually, a solution is found by combining the solutions to the sub-problems. The recursive fractioning of a problem into small problems can allow, with constant effort, a solution in a shorter time by parallelizing task performance.<sup>116</sup>

---

<sup>116</sup> The principle has found application in computer programming, where an entire group of algorithms named “Divide et Impera” exploit precisely this problem-solving strategy. The recursive reduction of a complicated problem in smaller sub-problems allows parallelized computation, thereby increasing

Another reason is economic, and concerns how institutional change is influenced by transaction costs in relation to group size: the present chapter offers an investigation of this second reason.

The problem faced by the upland village communities studied in this chapter is eminently economic: the historical evidence is that, using *Carte Di Regola*, hundreds of communities were able to sustain cooperation in resource extraction and to avoid the tragedy of the commons for more than six centuries (Casari, 2007; Ostrom, 1990).

The present chapter investigates the effects of fission–fusion strategies in governance structures and in institutional change: groups can solve collective action in institutions by organizing a large group in smaller clusters. Where a large group would fail the collective enterprise, the division of the group may ensure coordination in smaller units toward the collective goal: therefore, a divided and structured group may be better able to overcome the collective action problem.

Recall that in the process of institutional change, population growth is assumed to be exogenously determined. Under this assumption, the increase in group size – in this chapter proxied by village population – leads to group fission–fusion and to the creation of structured interactions of subgroups, which allow the minimization of transaction cost and the further increase of the total group size, while at the same time the strategy allows solving the problem of collective action.<sup>117</sup>

This chapter logically continues the investigation carried out in Chapter 5 on the consequences of the existence of a threshold in group sizes under different institutional regimes. From the methodological point of view, this study is inspired by a family of qualitative studies under a methodological paradigm that, in the social

---

computational efficiency. An example of these algorithms is the “mergesort,” attributed to John Von Neumann in 1945. For a reader-friendly treatment of the issue, read Knuth (1998).

<sup>117</sup> See Section 5.1 and Kremer, 1993.

sciences, has been termed “grounded theory” (Bryman, 2010, pp. 541–550).<sup>118</sup> The current chapter is a presentation of results that does not fully reflect the path followed in the research in chronological order: the research started from the systematic observation of the available data on the fission–fusion behavior of groups in formal institutions. First, coding, concepts, and categories were elaborated, and the framework was refined with constant comparison with the documents until categories became saturated. The research question was then formulated, and in many cases the present author proceeded to the collection of new data and to the refinement of a concept of the research question: the results of this stage are the fission–fusion dataset and the cases reported in Appendix B, which integrate this study. Next came analyses to confirm the conjecture, and this concluded with a theoretical model of institutional change that lines up with the observed data. The main purpose of this effort was the extrapolation of theoretical implications on two levels: first, the compatibility with the threshold hypothesis expounded in Chapter 4, and second, the compatibility of the observed phenomena with existing theories of group behavior and institutional change.

The chapter is organized as follows: Section 6.2 describes the methodology adopted to select the cases: collecting, organizing and analyzing the data using

---

<sup>118</sup> Grounded Theory (GT) is a research methodology for analyzing qualitative data proposed by Glaser and Strauss (1967). The scientists defined GT as “the discovery of theory from data.” Unlike other methodologies in the social sciences, GT provides the researcher freedom of generating new concepts to explain human behavior by “letting the data speak.” The goal of the research is the formulation of hypotheses based on the systematic conceptualization of an observed phenomenon. One of the main concerns of researchers using this methodology is asking, “What is the main problem participants are going to solve?” in the observed phenomenon. GT is not simply a “descriptive” method but makes use of the inductive and then deductive method to formulate and verify hypotheses, respectively. Normally, the explanatory power of claims in GT does not rely on the traditional concept of statistical significance of key predictors but rather on probability statements (“whether it is plausible”) about the relationship of concepts and categories obtained after an organization of the data called “open coding.” Only once all these steps have been completed can a formal theory follow. Hence, GT is not concerned with “validity” in a traditional sense but mainly with the “fit” of the theory with the data. Another methodological profile relevant for this study is that, in GT, a pre-research literature review is considered potentially harmful to results, as it may insert preconceptions about what to find, and the researcher may lose sensitivity in creating new concepts.

categories created ad-hoc for the case studies. Section 6.3 illustrates the results of the analyses conducted on the data, discussing whether the results of the observation are compatible with the threshold hypothesis; a possible interpretation of the data is eventually offered by modeling institutional and organization changes along three dimensions: group size, transaction costs, and rents from production of a pool of common resources. In Section 6.4, a discussion of the limitations of this study concludes the chapter.

## **6.2. Methods**

The present section expounds the methods adopted to study fission and fusion behavior. Subsection 6.2.2 describes the criteria for the selection of relevant cases and their classifications according to the process of substantive coding from the original legal documents. Subsection 6.2.3 tackles the generation of codes, concepts, and categories for reconstructing the internal organization of each of the units of observation in every observation period. Subsection 6.2.4 describes the methods followed for the production of group size estimates.

**6.2.1. Case selection and data categorization.** To provide evidence for the hypothesis, the fission–fusion database is built (Section 3.3). The dataset reconstructs details of 21 multi-village organizations representing 129 villages in total and a control group of 76 stand-alone villages in the Italian Alps between the year 1267 and 1796.

Due to a limitation inherent in historical data, full details on fission and fusion behavior could be provided only for formal institutions, because of the availability of written documents. The present research, however, does not exclude the existence of fission and fusion behavior also in multi-village organizations under an informal regime. Events referring to villages under informal institutions are inferred from the

institutional changes that occurred in the multi-village organizations selected for this study.

The villages are observed during their institutional changes in the management of common resources as the population increases. These village communities used *Carte* to self-govern their economic life for six centuries (from 1202–1807). The analysis focuses on the relation between the size of face-to-face assemblies of group members and the internal structure of groups.<sup>119</sup> For ease of reading, the concepts and the categories extrapolated after the observation of each of the case studies are presented, followed by a description of the fission–fusion dataset.

To describe fission–fusion behavior of groups in institutions, the dataset distinguishes the organization of the multi-village from the resulting governance structure of the organization. Observing a multi-village organization normally entails the adoption of a *Carta* and, therefore, the setting up of a formal institution that may govern more than one village. The governance of the institution may be developed in one or more layers.

The formal regulation of collective action in the rural charters shows evidence of fission and fusion of communities over time. In the present case study, sometimes face-to-face interaction occurs in communities that are structured in two or more coordinating subgroups. Such communities are termed multi-layered. Multi-layered communities are distinguished from single-layered and cluster communities. The distinction between single-layered and multi-layered communities concerns the governance of communities. Single-layered communities can be ruled under either an informal or a formal regime, while multi-layered communities require a formal institution. In a single-layered community, active members meet only in a general

---

<sup>119</sup> In Appendix E, a detailed case history is provided in the form of summary tables.



assembly (or do interact informally, if the single-layered community does not have a formal regime), and all members have access to all of the common resources according to the assembly regulations. In a multi-layered community, at least one of the two criteria does not hold: either there are separate assemblies by village or subgroup or there is a partitioning of the common resources for use by village or subgroup or both.<sup>120</sup> A multi-layered community may include two or more bordering villages, or it may consist of a multi-village organization or a cluster of more villages. In that case, the general assembly may still include all members or only selected representatives from each village or a subgroup of members. These concepts are summarized in Table 6.1.

**6.2.2. Internal structure of multi-village organizations.** In multi-layered communities, face-to-face interaction may occur in multi-village assemblies gathering the whole group of appropriators from all the communities; however, collective action problems are more often resolved face-to face at the single-village level (with or without recourse to a formal institution). In this case, each village subsequently sends its representatives to the multi-village assembly for the purpose of coordinating a collective action in the multi-layered structure (Figure 6.1).

---

<sup>120</sup> *Examples.* In the community of Fiemme, for centuries, the common pastureland was divided in multiple parts and then assigned on a rota basis to a group of villages belonging to the community. Coredo, Smarano, and Sfruz were a single-layered community with common use of the land, with a general assembly; Don, Amblar, and Romeno were a single-layered community, and the content of the rural charter was the common use of pasture.

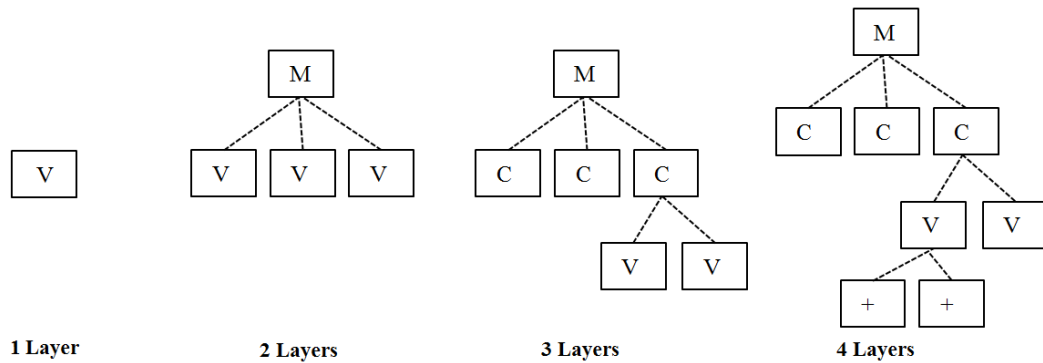


Figure 6.1. Internal structure of multi-village organizations.

Note. “V” stands for (single) “Village”, “C” for “Cluster”, “M” for “Multi-village”.

Figure 6.1 represents the categories adopted to interpret the internal organization of communities including more than one village (multi-village communities). Communities with more than 1 layer are defined “multi-layer”. The others are “single-layer” (or “one-layer”). *Multi-layer communities* (MV, MCV, MCV+) are organizations of multiple villages in which collective action is structured in two or more levels. *One-layer communities* are single-village interaction units within (or independent from) the multi-village organization (V). Therefore a single-village that at some point in its existence belongs to a multi-village organization, having it a charter or not (that is, having it surely a village assembly or not), is considered “one-layer”. Appropriators are deemed to interact face-to-face in that village. Similarly, are considered one-layer also “Stand-alone” communities: villages that at some point in their life adopt a charter. Stand-alone communities are deemed to have a face-to-face appropriators’ assembly at the village level, and represent a separate group of control in statistical tests. A multi-village organization (M) is instead regarded as a one-layer if in the single villages do not adopt charters individually (there is only one organizational layer). *Clusters* may be made of one or more villages. They are multi-village or single-village organizations. When they are

single-village organizations, they are never from the Stand-Alone sample. They usually aggregate one or more villages from a multi-village organization for a limited period of time after (1) the fission of a multi-village organization, (2) the merge of two or more villages belonging to the same multi-village organization, (3) the aggregation of one or more villages resulting after the fission of a multi-village organization in a multi-layered structure (i.e. Valley of Fiemme).

The distinctions above were drawn after observing a selection of 21 cases of multi-village organizations, and this paragraph summarizes the four criteria adopted for selection. First, only formal multi-village organizations were selected (Sample 1),<sup>121</sup> and the informal ones were excluded, because they never had a charter during their existence, and thus, an institutional analysis would be not precise: if registered in the dataset, they were regarded and recorded as stand-alone communities. Information on internal groupings in each multi-village organization was obtained using the border reconstruction made in Casari (2007); Casari and Lisciandra (2010) used the description of the boundaries in the text of rural charters matched with the details in the cadastral units in 1897 (Consiglio provinciale d'Agricoltura pel Tirolo, 1903).<sup>122</sup> Therefore, a complete list of villages belonging to multi-village organizations was obtained (Sample 2). Second, multi-villages of which there was no partial list of the villages belonging to the multi-village available were also excluded from the selection. From this shortlist, 26 cases of formal multi-village organizations were identified. Single villages that never had a charter may have been included as single

---

<sup>121</sup> Recall that multi-village organizations can be informal when they do not adopt a charter; otherwise, they are formal.

<sup>122</sup> It is possible that the 21 cases selected in this chapter are not all the existent multi-villages, as the selection was based on the division in cadastral units dated 1897 and on the text of rural charters. Other cases may be existent, and those not observed might also have less institutional changes than those observed in the current selection. This might constitute a potential selection bias in the data. So far, no other case fitting with the requirements listed above has been found by the present author, and these potential cases are considered among the 76 stand-alone villages included in the control group.

villages in a multi-village organization and participated in the collective action for the management of the commons. Third, the following were dropped from this shortlist: Trento (it had a statute, not a charter), Vezzano and Padergnone, Primiero, Val di Fassa, and Ton (too few observations, or no change of interest for this study). Fourth, multi-villages not having a population estimate in 1800 were also excluded from selection.<sup>123</sup> Another important criterion relevant for selection was to consider stand-alone villages separately (Sample 4). Stand-alone villages never belong to a multi-village during their existence and were considered one-layered structure communities by default.<sup>124</sup> They were considered as a “control group” in the present analyses of the effects of fission and fusion in multi-village organization.

The multi-village organizations selected are 21, and represent 129 villages at the year of first and last institutional change.<sup>125</sup> The selected case histories constitute the fission–fusion dataset, an unbalanced panel that observes each village at every grouping level at every year of occurrence of an institutional change. Sample 2 observes the behavior of 28 temporary groupings of villages. Sample 4 observes 76 stand-alone villages at the years of first and last institutional change. There are 1,013 village observations in the database in total. The period covered in the dataset is 529 years (1267–1796).

**6.2.3. Internal structure of communities.** This subsection describes the concepts and the categories used to organize the data on village population. In the organization of each multi-village community, there are three grouping levels that

---

<sup>123</sup> Their inclusion would have prevented the calculation of a population estimate also of all the villages belonging to the multi-village at the time of every institutional change recorded in the documents dataset, reporting all the information concerning charter adoption and renewal (Casari & Lisciandra, 2010).

<sup>124</sup> Hence, when calculating statistics on the distribution of the appropriators’ group size of stand-alone villages, it is possible that the real figures are overestimated.

<sup>125</sup> Table 6.3, Appendix D, lists the 21 cases with the number of villages in each one, recorded at the year of last institutional change.

may or may not exist: the village level (Level 1), the multi-village level (Level 2), and the cluster level (Level 3, represented in Sample 3). In each of the levels, it was determined whether there was an assembly or not using the data about charter adoption (the documents dataset): if a charter was adopted in the level, there was necessarily an assembly.

Considering all the villages (Level 1) and all the years in the dataset, only one-third of the observations had an assembly at the village level (340 observations out of the 861 involving villages in multi-village organizations). Of the clusters, 68% had an assembly at the cluster level (334 observations out of the 861 involving villages in multi-village organizations). Of the multi-village organizations, 78% had an assembly at the multi-village level.

At the year of last institutional change, the numbers do vary significantly: 66% of the multi-village organizations (called communities in the previous chapter), 69% of the clusters, and 39.53% of the single villages had an assembly. In the 39.53% representing the villages within the multi-villages, stand-alone communities were not included:<sup>126</sup> in those dates, 62% of them (n=127 out of 205) would have had an assembly.

From the definition of the “assembly level” described above, two important features of the structure of community organization are inferred. The first concerns the number of layers compounding the structure of formal collective action, as described by the number of assemblies. From this point of view, villages were divided into four classes: ruled under informal interaction, one-layer, two-layer, and three-layer<sup>127</sup>. For example, if a community had an assembly only at the multi-village level and not at the village level, or only at the village level, it was considered a “one-layer”

---

<sup>126</sup> Stand-alone communities are observed at the first and the last institutional change.

<sup>127</sup> Table 6.4, Appendix D.

village. The second piece of information overcomes this limitation, as it offers a description of the structure based on the mix of the assemblies.<sup>128</sup> Another useful distinction to identify the layers is the one adopted at the beginning referred to the multi-village communities.<sup>129</sup> Consistent with similar findings in the literature (Zhou et al., 2005), the maximum number of layers of multi-village organizations is four, and 80% of the cases have between 1–3 layers.

**6.2.4. Group size estimates.** The criteria for the selection of the sub-sample of observations that was used to test the social brain hypothesis are as follows. First, group size estimates were computed for each of the observations in Samples 1, 2, 3, and 4. Therefore, group size estimates were obtained at every level: village groups, cluster groups, and multi-village groups. Estimates based on population data and estimates based on assembly data are distinguished.<sup>130</sup> Eventually, the level at which plenary face-to-face assemblies are held was identified.

*Estimates based on population data.* Population estimates include both the insider and the outsider groups, and provide a figure of the potential number of appropriators interacting in the commons. For each multi-village organization, the 1810 Napoleonic census data were extracted (Andreatta & Pace, 1981). Such data was also extracted for the villages included in the multi-village organization, when existent and when the census provided an estimate. Earlier estimates were computed using the Italian population trend calculated by Bellettini (1987) to scale back the 1810 population, rounded to the nearest integer. The validity of this procedure has been proven satisfactory for the Trentino case study.<sup>131</sup>

---

<sup>128</sup> Table 6.5, Appendix D.

<sup>129</sup> Table 6.6, Appendix D, contains a frequency distribution at the last institutional change.

<sup>130</sup> In Appendix E, summary tables are provided with the population statistics for each year in all the multi-village organizations.

<sup>131</sup> See Chapter 3; these estimates have been validated by cross-checking with population data points in a variety of other direct historical sources.

If the village existed, but no 1810 census data were available, the village population was set to zero throughout its life. When census data were available for a community that did not exist at a certain date, the population of that village was divided among all the remaining villages in the multi-village organization in proportion to the total population of the multi-village population represented by each single village. When no census data was available for the single village, but the census of all the other villages was available for 1810, the population of that village was obtained by subtraction from the total of all the other villages. When no census data was available and the village was not existent, the village was removed from the dataset. A null estimate was eventually obtained for 143 villages, and three villages at the cluster level corresponding to one cluster (out of 861 observations over time). All the remaining observations have a population estimate.

The population of the 76 stand-alone villages (Sample 4, the control group) is obtained by extracting the first and the last institutional change<sup>132</sup> from the documents dataset provided by Casari and Lisciandra (2010) and applying the same procedure (1810 census data and backward projections of population using the Italian population trend, rounded to the nearest integer).

***Estimates based on assembly data.*** Estimates based on assembly data are obtained from the appropriators' group size estimates in the previous chapter: this estimate isolates the insiders' group in total population and is therefore smaller than the population estimate. This figure is useful to understand assembly interaction and the number of appropriators allowed extracting resources on the commons. It was also thought that the level of mutual knowledge among the insiders was higher and that

---

<sup>132</sup> See Section 6.2.6.

regular face-to-face interaction was more frequent. These estimates are superior to population estimates in terms of accuracy, as their origin is from first-hand data.<sup>133</sup>

**6.2.5. Considering plenary versus partial assemblies.** Legal rules on the management of the commons are written in the village statute (*Carta di Regola*) and decided in village assemblies through a process of direct voting. Therefore, the charter is the main source to understand the dynamics of interactions within a village. In order to be able to test whether the threshold hypothesis is compatible with the data, it is necessary to identify the largest group of interactants in each of the assemblies in each of the three levels: multi-village, village, and cluster. The goal is to identify, within the villages observed at the last institutional change, when the assembly is plenary or partial. “Plenary assembly” is defined as a group size estimate that represents the largest face-to-face group of interactants, even when collective action is structured in more than one level. Plenary assemblies are distinguished from “partial assemblies,” where only village representatives participate in the face-to-face interaction. If the multi-village or the cluster group has a charter, the assembly may count only the representatives from the villages (partial assembly) that ratify decisions taken at the village level in a plenary assembly; alternatively, it may be that all the households’ members from all the villages participate in the assembly and cast their vote in a multi-village plenary assembly.

In the analysis of the whole charter set of village and multi-village organizations at the last date of institutional change, plenary assemblies are identified using the following three criteria. First, if the charter of the multi-village or the cluster organization explicitly reports a complete list of participants from all the villages and the voter turnout, the assembly is considered plenary, and is attributed a unique code.

---

<sup>133</sup> The reader is invited to consult Chapter 3 for details concerning the reconstruction of group size estimates based on assembly data.



Second, the absence of a list of attendance at the multi-village and cluster level jointly with the existence of at least a village having a village assembly within the multi-village assembly interprets the multi-village or the cluster assembly as a partial assembly; therefore, the multi-village organization has plenary assemblies at the village level. This evidence is further corroborated by the presence of a list of attendance at the village level with the report of the voter turnout with a high correlation between the estimate of the appropriators' group obtained using population and the estimate obtained using the assembly data.<sup>134</sup> Third, a village assembly is assumed when there is no plenary assembly at the multi-village and cluster level, and the village does not yet have a charter. To the ends of the solution of collective action, informal interaction has effects that are analogous to a plenary assembly. Therefore, villages without a charter are regarded as having an assembly at the village level, particularly when at least one village within the multi-village organization has an assembly at the village level. At the year of last change, only five villages had plenary assemblies.<sup>135</sup> The same criteria were used to identify the plenary assemblies for the first institutional change.<sup>136</sup> Again, this study found a strong prevalence of assemblies at the village level (only 10 villages have an assembly at the cluster or multi-village level). The results of a correlation analysis support the validity of the second criterion.<sup>137</sup>

---

<sup>134</sup> Using Sample 3, the Pearson's correlation with appropriators' group size is  $\rho=0.1535$ , still positive but not statistically significant. The Spearman rank correlation on  $n=12$  gives a correlation coefficient of  $\rho=0.244$ , and the two measures are independent ( $\text{Prob}>|t|=0.4433$ ); using Sample 4, a Pearson's correlation of  $\rho=0.4299$ , significant at the 1% level, is obtained. The Spearman rank correlation on  $n=36$  is 0.568, and the samples are statistically not independent ( $\text{Prob}>|t|=0.0003$ ).

<sup>135</sup> Table B.3, Appendix D.

<sup>136</sup> Table S.4, Appendix D.

<sup>137</sup> Using Sample 3, the Pearson's correlation is  $\rho=1.00$ , significant at the 1% level. The Spearman's rank correlation on  $n=2$  gives, obviously, a correlation coefficient of 1; using Sample 4, a  $\rho=0.639$ , significant at the 1% level, is obtained. The Spearman's rank correlation on  $n=28$  is  $\rho=0.749$ .

Institutional changes recorded by rural charters are considered. The present analyses excluded charters not regulating the commons. Statistical analyses considered the first and sometimes the last institutional change. The sample belonging to the last institutional change includes 205 villages (Sample 2 and Sample 4), 129 under the 21 multi-village organization, 76 stand-alone. The first reason for this choice is based on the fact that many villages report a date of foundation (reconstructed using the year of the first document written in the village or mentioning the village) that is later than the first institutional change; thus, observing the first institutional change would lead to missing observations (but would be useful to capture the evolution of the internal structure of the multi-village organizations: this sample will be used later). The second reason for this choice is that population grew dramatically from 1200–1800,<sup>138</sup> and choosing the last institutional change ensures observation at the maximum group size.

**6.2.6. Fission, fusion, and institutional change.** This chapter analyzed the structure of multi-layered communities and the largest unit where interaction occurs face-to-face. The focus is on group size at the moment of institutional changes and, in particular, when institutional changes bring about the fission of the multi-villages into smaller subgroups or the fusion of single villages into a structured multi-village organization. In studying institutional changes, the multi-village organization as the unit of observation is considered.

Three institutional changes are defined: individual adoption, fusion, and fission. Empirically, these institutional changes – and particularly the fusion – are not sudden one-step decisions, but entail a series of intermediate steps. The next paragraphs introduce a discussion of each institutional change.

---

<sup>138</sup> Figure 3.1, Appendix C.

“Individual adoption” is the transition of a village from an informal regime to a formal institution. This change is the initial status from which further changes of a multi-village are considered. It is assumed that, once a community adopts a charter, the charter is enforced until 1800; that is, there is no switchback to the informal status.

Often, individual adoption is followed by a fusion, the merge of the villages in a multi-village organization. The fusion is oftentimes followed by a fission event, underlining a collective action problem.

The fission phenomenon is described with four alternatives: coexistence, clustering, clustering and coexistence, and independence. Fission events can be “strong” or “weak” in terms of the intensity, measured by transaction costs they require to be enforced.

a) *Strong fission*. Events of two types entail and generate “high” transaction costs. The first is the split of a multi-village into two or more independent clusters because of the independent adoption of a charter by one or more of the villages. This event is termed “independence,” because with the adoption of a charter, the villages separate their interaction from the multi-village organization and have an assembly independent from the multi-village one and from those of the other villages. The second strong fission event is termed “clustering,” and occurs when the multi-village structures operate by letting each village organize independently in clusters of one or more villages, which send to the multi-village assembly only the representatives of villages (i.e., *Val di Fiemme*).

b) *Weak fission*. Two events are regarded as weak institutional changes.<sup>139</sup> The first is defined as “coexistence”, and is a fission event comprising the adoption of a charter by one or more villages that does not require bargaining with all the other

---

<sup>139</sup> “Renewals,” amendments of a previous regulation, are not regarded as proper changes involving fission–fusion and therefore are not considered in the analyses.

villages or the multi-village organization while coexisting with the multi-village charter. This event may occur also after a fission clustering, hence generating a second weak institutional change, termed “clustering and coexistence”: this case occurs when, within a cluster, one or more villages may decide to have a village charter coexisting with the cluster charter and the multi-village charter (if any).

Table 6.9.

*Institutional changes and group size in 1200–1800: detail*

Change Type	Intensity	Freq.	Percent	Group Size		
				Mean	min	Max
Fusion → Fission independence	Strong	2	3.77	515.5	290	741
Fission clustered coexistence → Fission independence	Strong	1	1.89	561	561	561
Fission independence → Fission independence	Strong	3	5.66	587	383	986
<i>Ending in fission independence</i>		<i>6</i>	<i>11.32</i>	<i>591.33</i>	<i>290</i>	<i>986</i>
Fission coexistence → Fission clustering	Strong	2	3.77	1077	561	1593
Fusion → Fission clustering	Strong	6	11.32	1793.16	378	4644
Fission clustering → Fission clustering	Strong	3	5.66	1319	378	3073
<i>Ending in fission clustering</i>		<i>11</i>	<i>20.75</i>	<i>1533.63</i>	<i>378</i>	<i>4644</i>
Fusion → Fission coexistence	Weak	10	18.87	830.7	102	2201
Fission coexistence → Fission coexistence	Weak	22	41.51	2453.22	157	6259
Fission clustering → Fission clustered coexistence	Weak	4	7.55	1536.5	217	3351
<i>Ending in fission coexistence</i>		<i>36</i>	<i>67.93</i>	<i>1900.66</i>	<i>102</i>	<i>6259</i>
<b>Total</b>		<b>53</b>	<b>100</b>			

*Note.* The mean group size is referred to the largest cluster after institutional change, and is rounded to the nearest integer. Source: dataset constructed by the Author.

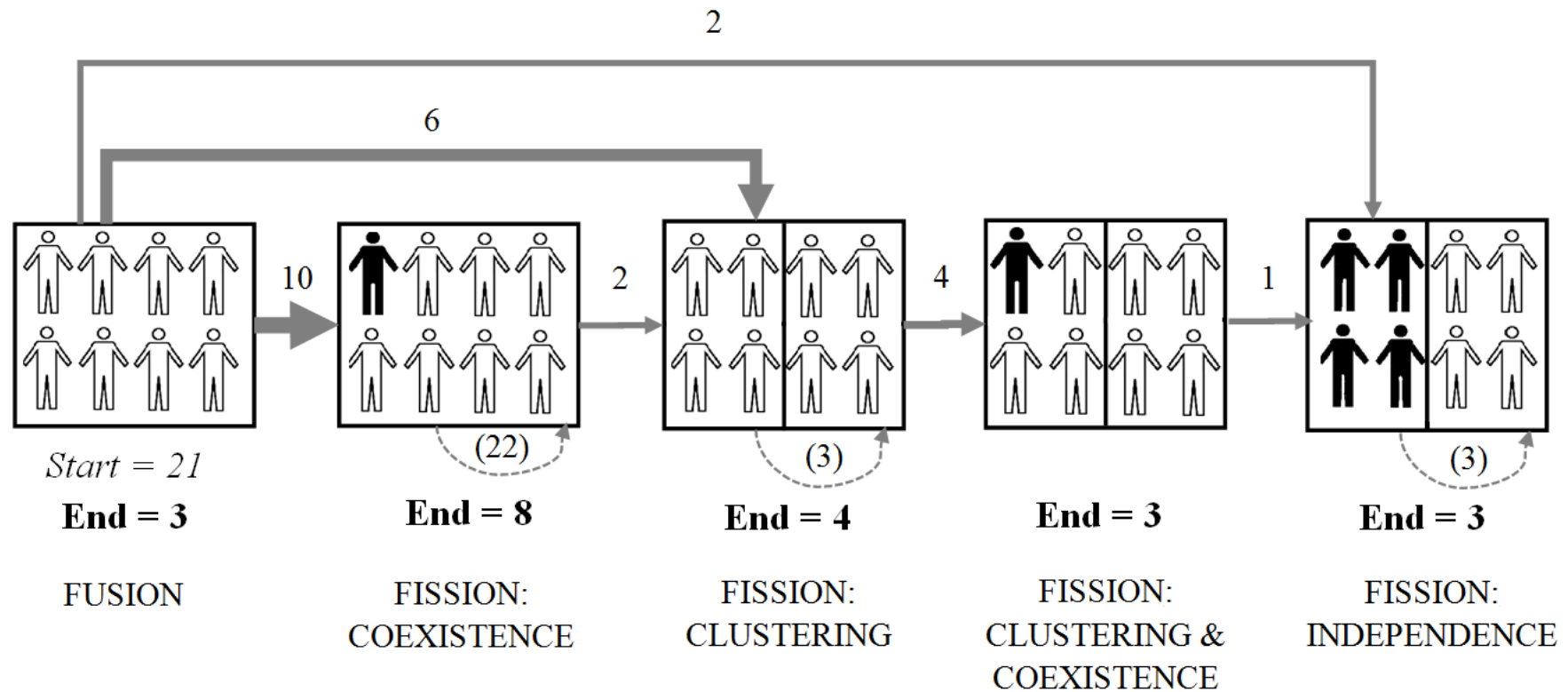


Figure 6.6. Institutional changes through fission–fusion in 1200–1800.

Note. The figure illustrates a total of 53 institutional changes. We start from the FUSION box with 21 multi-villages. The number next to “End” denotes the number of multi-villages in the corresponding box in the year 1800. Arrow widths are proportional to the frequency of changes. The dashed lines denote loops, institutional changes of communities within the same box. The numbers of loop changes are in parentheses next to the dashed lines. Source: dataset constructed by the Author.

### 6.3. Results and Discussion

**6.3.1. Empirical strategy.** The present subsection illustrates the results of the systematic observation of the case studies. As anticipated, this chapter presented statistical analyses of the cases after the presentation of coding and data organization, while the research analysis and coding employed a “circular” process involving observation, categorization, analysis, comparison across categories, and in some cases additional data collection. The results presented here are, therefore, final considerations drawn upon the completion of the process.<sup>140</sup>

Based on this information, this study performed statistical analyses on the internal structure of communities in relation to population. Based on the internal structure of communities, the population was compared across different group levels; alternative group size estimates were also used; eventually, analyses were performed separately for the first and the last institutional change observed in plenary meetings; the pattern of 53 institutional changes that occurred in the 21 multi-villages were studied, and these changes were placed in relation with population size. Subsection 6.3.7 provides an interpretation of the findings using a simple economic model.

**6.3.2. Internal structure of communities.** In multi-village organizations observed during their last institutional change, when group size increases, the number of villages comprised in each multi-village also increases. The pairwise correlation is  $\rho=0.64$ .<sup>141</sup>

**6.3.3. Internal organization of multi-village organizations.** This result can be considered a first evidence of the existence of an internal organization result of fission–fusion strategies: larger multi-villages have a higher number of within-

---

<sup>140</sup> The results of this process are organized in the tables in Appendix C. These tables reconstruct the institutional history of each of the 21 multi-villages and of the within-villages for each year of observation.

<sup>141</sup> Figure 6.2, Appendix C, and Figure S.2, Appendix C, for the first institutional change.

villages. In addition, as the population of multi-villages increases over time, generally, the number of within-villages increases.<sup>142</sup> The equation of the linear fit reports the following results:

$$N_{\text{villages}} = 2.918 + 0.001 \cdot \text{POPULATION}_{\text{multi-village}}$$

(0.726)\*\*\*    (0.000)\*\*\*

$$R^2 = 0.54; n = 21$$

The coefficient before  $\text{POPULATION}_{\text{multi-village}}$  has been found to be statistically different from zero (Prob>F=0.0078). If a multi-village is considered at its last institutional change with a population equal to 1,000 inhabitants, the number of villages that are included is predicted to be, on average, 3.918. This increase is statistically significant at the 1% level. This result is interpreted to index that, as group size increases, the internal organization of communities becomes more complex. Fission events (the increase of the number of within-villages) may be aimed at solving this complexity: the fission of a village may bring a reduction of transaction costs within the multi-village.

**6.3.4. Group size estimates.** It is useful to recall that “group” refers to the size of villages, clusters of villages, the size of multi-village communities, or the size of the largest face-to-face group (village, cluster, or multi-village) at the last institutional change and is expressed in terms of population when not otherwise indicated. Analyses are therefore carried out to compare the size of these groups across their categories. The purpose of this comparison is twofold: (a) to test whether groups belonging to different levels differ significantly in size and (b) to test whether group size estimates are within Dunbar’s range—a contingency that would allow testing the threshold hypothesis in the context of fission–fusion behavior.

---

<sup>142</sup> The reader can find a scatterplot also for the first institutional change in Figure S.2, Appendix C.



The median sizes of single villages are remarkably similar (310, 306, and 366). In addition, there is little difference between the median size at the first (306) and the last (366) institutional change in stand-alone villages.<sup>143</sup> The variation (measured by the IQR) is also similar (526 and 566). As previously commented in Chapter 5, population estimates include both community members and non-members, and indicate the potential number of appropriators on the commons. Unlike the results in Chapter 5, this time, it has been possible to identify the largest face-to-face group of interactants, albeit with two limits. The first is that these estimates were based on population size; therefore, the medians—although indicators of a central value robust to outliers—are still overestimating the number of effective appropriators on the commons because they also include outsiders. The second is that these estimates are performed only for the first and last institutional change.

Using direct observation of assembly participation assemblies,<sup>144</sup> quorums, and household size, an estimate of the insider group size was computed in Chapter 5, and the number of appropriators in each community where an assembly has been observed plotted, this time selecting only the sample of communities involved in fission–fusion ( $n=173$ ). The scatter in Figure 6.3 (Appendix C) visually separates villages from clusters and multi-villages, while Table 6.8 (Appendix D) reports statistics in tabular form. The histogram (Figure 6.4, Appendix C) represents assembly size frequencies in custom-made classes at the last institutional change.<sup>145</sup> It is possible to notice that Dunbar’s range is the assembly size in handling face-to-face interaction in assemblies (the absolute frequency is 56; the relative is 0.273).

---

<sup>143</sup> Table 6.7, Appendix D.

<sup>144</sup> Figure S.3, Appendix C, in tabular form at Table S.2, Appendix D.

<sup>145</sup> The first institutional change is instead shown in Figure S.4, Appendix C.

**6.3.5. Village population distribution at last institutional change.** The analysis of the empirical distribution of group size is aimed at comparing the size of face-to-face interaction. A first comparison can be carried out on kernel density estimates: the visual evidence is that, generally, the control group (Sample 4) and the main group (plenary) have a similar distribution at the date of last institutional change.<sup>146</sup>

Statistical tests aimed at finding significant differences between distributions have also been carried out across samples during first or last institutional change. The empirical distributions of population estimates were first analyzed in Sample 4. The comparison was between the median population in plenary assemblies versus the median population of stand-alone villages. It was necessary to test whether there were significant differences between the medians of the two samples during the first institutional change and, later, during the last institutional change. In general, this difference is expected to be significant, since stand-alone villages should have a smaller size than units of plenary assemblies. In fact, at the first institutional change, the evidence indicates that the two medians are statistically different and that the median of the stand-alone sample is lower (Pearson's  $\chi^2=19.2873$ ,  $p$ -value=0.000,  $n=205$ ). At the last institutional change, the medians are, instead, found to be not statistically different (Pearson's  $\chi^2=0.8487$ ,  $p$ -value=0.357,  $n=205$ ).

The empirical distributions of plenary assemblies and stand-alone are now compared in first and last institutional change to see whether there are significant differences within the same samples that may underline time-dependent effects. Time is not expected to significantly change the distribution of Sample 2. Instead, Sample 4 is expected to shift to the right: the median of Sample 4 at the first institutional change

---

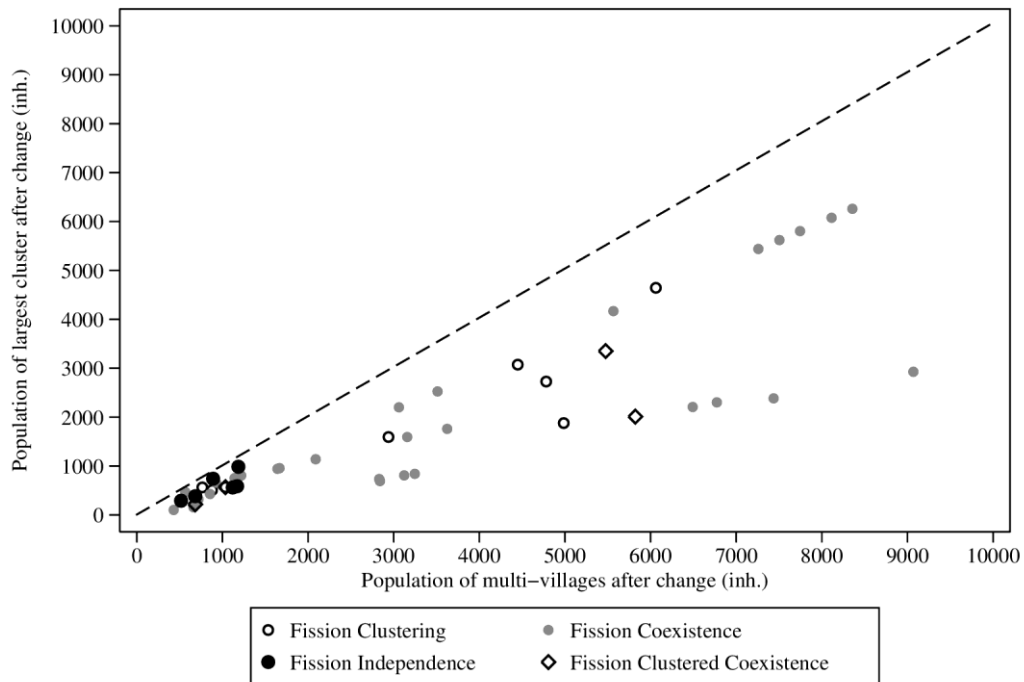
<sup>146</sup> Figure 6.5, Appendix C. The kernel densities for the first institutional change are in Appendix C at Figure S.6, together with a set of empirical distributions at Figures S.5 and S.7.

is expected to become significantly lower than the one of Sample 4 at the last institutional change. This would mean, assuming that while stand-alone villages are not sensitive to a population increase, the villages in the sample of last institutional changes can increase in size and solve the collective action problem using a different internal structure. In accordance with this intuition, the median of the stand-alone villages does not change statistically from the first to the last institutional change (Pearson's  $\chi^2=0.9474$ ,  $p=0.33$ ,  $n=152$ ), while the sample median changes significantly from the first to the last institutional change (Pearson's  $\chi^2=8.2049$ ,  $p=0.04$ ,  $n=410$ ): the median size of the villages in the sample of plenary assemblies increases.

**6.3.6. Fission, fusion, and institutional change.** Using the categories outlined in Section 6.2, this study identified 53 institutional changes involving individual adoption, fusion, and fission between 1276 and 1796. The general finding is that the institutional change follows a common pattern (Figure 6.6, below); namely: 1) fusion, 2) fission coexistence, 3) fission clustering, 4) fission clustering and coexistence, and 5) fission independence. Table 6.9 provides a summary in tabular form.

As in Figure 6.6, as to the intensity of institutional changes, 17 cases are strong institutional changes (32%, solid line), while the remaining are weak (68%, dashed line). Strong changes are those involving independence and clustering.

After observing the existence of a common path in institutional changes, the goal becomes to understand whether group size relates to institutional changes. An intuitive way to do this is observing how the size of the multi-village organization and the size of the largest cluster within the multi-village organization are distributed in a scatterplot after each type of fission event (Figure 6.7).



Note. N=53 Fission events are represented.

*Figure 6.7.* Institutional change, structure, and group size.

In this way, it is possible to observe whether the internal organization of communities exhibits patterns also in terms of size of the largest face-to-face interacting group after every institutional change that has been observed. Two facts are worth noting. First, the size of the largest cluster is variable but extremely stable in relation to the institutional change: as can be seen, an ideal linear fit would be almost flat. Second, the different fission types underline a precise “sequence” of institutional changes, so that multi-villages where the largest cluster had a strong institutional change (independence) are not greater than ~1,000 inhabitants, strong institutional changes with clustering do not occur over ~6,000 inhabitants (regardless of whether they are results of fission clustering or fission clustering and coexistence),

while weak institutional changes occur until ~10,000 inhabitants covering the full multi-village size spectrum.<sup>147</sup>

This evidence not only seems suggestive that the process of institutional change follows a precise path but also that this path is related with group size. It is conjectured that this relation between institutional change and group size may be driven by transaction costs. Each type of institutional change is conjectured to bring a different amount of transaction costs, in part dependent on the size of the group, in part dependent on other factors that can be “context specific,” to be considered necessarily under the *ceteris paribus* assumption. As a result, these analyses call for the clarification of a potential causal relationship running from increasing group size (because of assumed exogenous population growth at the beginning of this study) to increase in transaction costs, to internal organization of communities (layers) and institutional changes (fission and fusion behavior). Concerning fission events, in particular, some specific conjectures can be derived from the evidence found.

a) *Fission coexistence*. As group size increases exogenously, fission coexistence is the lowest transaction cost change a village may adopt to solve collective action: it does not involve bargaining costs with the higher organizational levels, and it is a decision that can be undertaken unilaterally at the village level to manage the commons by formally regulating interactions that would be otherwise left to informal interaction. The evidence in support of this claim is that this change was the first chosen by any villages and the most frequently reiterated in multi-villages: 22 “loops” are observed.

b) *Fission clustering*. As group size increases exogenously, fission clustering is a change that is the second most demanding in terms of transaction costs: it requires

---

<sup>147</sup> Table 6.9 for the results in tabular form.

the consensus of the highest multi-village level. However, the multi-village organization with a clustered internal structure has the major advantage of maintaining cohesion and bargaining power in political relations with the prince (e.g., the case of the Valley of Fiemme). In support of this claim, it was found that fission clustering is the second most preferred: four last changes and three loops are due to fission clustering.

c) *Fission independence*. As group size increases exogenously, fission independence is the highest transaction cost solution, comparable to the division of two countries. To negotiate the definitive separation, a smaller group size is required to allow face-to-face interaction, and this might explain why (a) only few cases of fission independence and few loops are observed, (b) all the changes are at a small group size.

**6.3.7. Interpretation of the results: a simple model.** As anticipated in the introduction, the rationale of fission–fusion behavior is mechanic, but essentially economic; this fact is abundantly documented in the animal world, where the essential traits of the “natural” economic rationale emerge most strikingly (Smuts et al., 1987, p. 248).

The evidence presented in Chapter 5 referring to the same case study shows how the exogenous growth of population carries to a first institutional change from informal to formal institutions, and this transition is interpreted to be compatible with the presence of cognitive limits and—on a statistical basis—incompatible with other alternative explanations.

The present chapter sought to find whether the internal structure of multi-village organizations and the type and timing of institutional changes can be determined by group size. It was observed that the same exogenous population growth

led to further changes in the internal structure of formal multi-village communities; that these changes followed a precise path; and that this path was related to the size of the multi-villages, their villages, and their clusters of villages.

Since observations are limited, the following subsection offers a possible interpretation of the results by means of a simple economic model. It is useful to recall the context of the model: the groups in this study are communities acting on common-pool resources. Unlike other models of optimal resource use, which consider mainly production costs and technology (Clark, 1990; Gordon, 1954; Hardin, 1968; Schaefer, 1956), this model accounts also for positive transaction costs (Allen, 2000) and the presence of two alternative institutional forms (informal institutions, and the *Carte Di Regola*). Most importantly, the model accounts also for the exogenous changes in group size (Kremer, 1993) as one of the key predictors of transaction costs in institutions. The two excerpts quoted in the previous subsection support this view: after the adoption of a formal institution, the community cannot increase unboundedly. There is an upper limit subject to the condition of optimal resource use determined by the presence and the enforcement of a *Carta di Regola*.

The situation depicted as “excessive group size” can be resolved by the community in three ways: (1) impoverishment, (2) migration, or (3) changing the internal organization of the community by replacing or amending the institution, thereby increasing the level of aggregate surplus from production available at the village level. The third is the one observed in this chapter. The internal organization of the community can be changed in two ways: (a) by simply amending or replacing the “technical” rules of resource management without changing the structure of the community or (b) by changing the structure of the community. While (a) will be treated in Chapter 8, this chapter focuses on changes in the internal structure:

individual adoption, fusion, and fission. The link between these changes and transaction costs is also underlined by the second of the excerpts in the preceding subsection: fission normally occurs in a way that produces cohesive groups. Cohesive groups are defined as groups in which heterogeneity of individual preferences is low. Such groups are characterized by the presence of cooperation levels that are generally higher than those of groups with a high heterogeneity of individual preferences.<sup>148</sup> The reason for this regularity is that in a cohesive (and, to some degree, homogeneous) group, trust and social capital are more likely to emerge: as a consequence, group members benefit from low transaction cost relationships (Putnam, 1993). The community is assumed to engage in fission–fusion behavior when its marginal benefit of doing so outweighs its marginal costs; therefore, a relation between production costs, transaction costs, and group size could be explanatory of the institutional changes observed.

The next paragraphs set up of the model, state the welfare problem, identify the optimal group size, and offer a number of predictions on institutional changes.

**Model setup.** Consider a group of  $N$  homogeneous individuals using a natural resource under a decentralized common property regime in Ostrom’s sense (1990). The condition of optimal resource use would lead to rents from production constant with the increase of group size. In fact, if it is assumed that the common resource is always harvested at fully cooperative equilibrium, at any time, the amount of resource harvested by the group is equal to the sustainable resource production at most.<sup>149</sup>

The aggregate surplus ( $\omega$ ) is defined as the aggregate rents from production ( $\pi$ ) minus the transaction costs ( $\psi$ ) borne by the group. Aggregate rents are defined as the difference between production costs and total revenues from production of the

---

<sup>148</sup> For a discussion and empirical test of social and resource fractionalization in groups and institutions, please see Chapters 7–8.

<sup>149</sup> In this model, for simplicity, adjustments of group size because of discounting are not considered.



group's aggregate portfolio of resources at a given time. The aggregate portfolio of resource is defined as the sum of individual equilibrium resource portfolios (the amount of resources extractable by each user at the equilibrium level), which, in turn, are composed of different types of resources which may have a different yield. Total revenues from resource production can be calculated as the yield from resource production of each resource type in the resource portfolio of the considered community times the unit price of each resource, here assumed constant over time. Returns of scale are assumed constant (Bardhan, 1973; Douglas, 1976; Mundlak, 2005). The definitions of "production costs" and transaction costs in this context are germane.

The aggregate costs of production are the costs of aggregate effort employed in resource extraction and depend on the group size. The cost of the aggregate effort depends on the technology of extraction, the amount of workforce available using the technology, and the amount of labor exerted on the commons to extract a given quantity of a resource. This cost is assumed constantly at the optimal level (slightly lower than the cost at a zero-growth level) over time, so that rents are always a fixed proportion of revenues. When the amount of effort remains stable over time, the cost of effort is optimal. If the aggregate cost of effort is at optimal level as group size increases, the shape of  $\pi$  does not change with group size and can be approximated with a horizontal line. Finally, rents from production do not depend on transaction costs.

Transaction costs ( $\psi$ ) are defined as the costs of collecting and disseminating information about the state of depletion of the resource and about the behavior of the other group members: basically, the costs of writing and enforcing an agreement to implement optimal resource use. It is assumed that transaction costs increase more

than proportionally to the increase in group size. The discount rate is assumed to be very close to zero.<sup>150</sup>

Individuals in the group endorse a set of bargaining efforts that tend to increase transaction costs. These efforts can be expressed in terms of participation, communication, and thrust to implement agreements. If individuals rely only on informal interactions, this cost component is limited to the communication effort. Participation effort is the cost of participating in an assembly where other people are gathered and interact simultaneously. Communication effort is the cost entailed by the set of actions performed by members to effectively vehicle information to other members, both under informal institutions and legal institutions.<sup>151</sup> Implementation effort is the cost of reaching a decision in collective action, after the negotiation has taken place. Transaction costs in each time are modeled as a function of bargaining costs, monitoring costs, and enforcement costs for each individual in the group in the considered time (Dahlman, 1979). While individual bargaining costs tend to increase more than group size, monitoring and enforcement costs tend to be higher when few people are on the resource, decrease due to “network effects,” and then increase as the network gets more complex due to the increase of the distances among the individuals (that is, the steps needed to connect  $i_1$  to  $i_2$  are probabilistically higher in a larger

---

<sup>150</sup> The welfare implication of a fully cooperative equilibrium as designed in this model is that each individual wishes always to cooperate (has no time preferences). Mathematically (Conrad, 2010), on an infinite discrete time horizon, this means that if the present value of aggregate rent  $V$  (supposing that  $V_0 = 0$  and  $V_t = \omega_N$  for  $t = \{1, 2, \dots, \infty\}$ ) has to face a discount rate  $\delta \rightarrow 0$ , then the discount factor  $\rho = \delta / (1 - \delta) \rightarrow \infty$  and future payments are basically unaffected by discounting because

$$\omega_N = \sum_{t=0}^{\infty} \left( \frac{1}{\delta} \right) \left( \frac{1}{1-\delta} \right) \omega_{N_t} = \frac{(1+\delta)}{\delta} \omega_{N_t} \approx \omega_N. \text{ The same can be proven for a stream of payoffs in a}$$

continuous time  $\omega_N = \int_0^T \omega_N(t) e^{-\delta t} : \text{if } T \rightarrow 0 \text{ and } \delta \rightarrow 0$ , the aggregate payoff equation can be integrated as  $\omega_N = \omega_N / \delta \approx \omega_N$ .

<sup>151</sup> This effort type is considered devoid of negotiation.

network with the same number of links – i.e., when people do not perfectly know who's who in the group). Hence, the relation between transaction costs and group size can be approximated by a *U*-shaped curve.

Monitoring is defined as the cost of individual direct collection of information about the level of exploitation of the resource and about the behavior of insiders and outsiders in the same commons. Monitoring enables the individual to detect rule violation on the commons. The cost of discovering an outsider in an area assigned to individuals is highest when the individual is alone. As group size increases, it becomes progressively easier to control the area if there is an informal or a formal agreement among insiders. However, at a certain point, individuals experience difficulty in remembering all the members of the agreement (Dunbar, 1993a, b, 2003; Miller, 1955). Memory constraints become material if the group counts people coming from different communities. If there are neighboring villages, people may find it difficult to distinguish insiders from outsiders by memory only.

Transaction costs are affected by enforcement levels: as group size increases beyond the optimal level, the failure to recognize who is responsible for damaging or over-extracting in the commons requires investments to (a) clarify legal property rights in order to reduce revenue variability affecting economic property rights, (b) properly govern a larger polity that enforces property rights, and (c) reward monitors and punish trespassers and monitors when necessary.

***The welfare problem.*** Even when the group decides to pursue the condition of optimal resource use, the aggregate surplus is devoured by transaction costs. Since the group is burdened by an amount of transaction costs which varies with group size, a variation in group size is translated in a variation of aggregate surplus.

**Optimal group size.** The optimal group size is reached when the aggregate surplus  $\omega^*$  for  $N$  at the time of observation is maximized. In a situation of optimality, the group maximizes the total subject to two fundamental conditions:

1. Aggregate rents from production are constant as group size increases;
2. Transaction costs are convex and can be minimized.

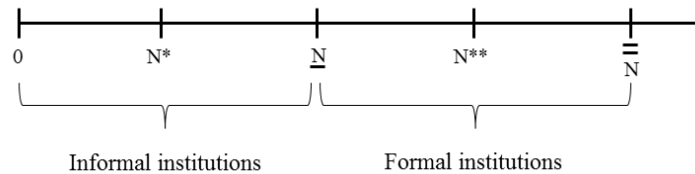
In other words, at the optimal size, the group enjoys the highest attainable surplus from production net of transaction costs. Rules in formal and informal regimes that aim at rent maximization for the group are regarded here as “rent maximizing rules” (Ellickson, 1991). When group size increases, transaction costs decrease until a minimum is reached; informal interaction among users allows better control of the area and, subject to the zero-growth condition, surplus production available increases steadily until a maximum at  $N^*$ , where aggregate surplus is maximized and transaction costs minimized. After  $N^*$ , transaction costs increase rapidly because of the increasing difficulty of interaction among resource users, and the competition in accessing the resource leads to a progressive erosion of the surplus. The situation is sustainable while there is available surplus; however, if the group increases further, rents disappear, where  $\psi = \pi$ . The tragedy occurs when  $\psi > \pi$ , when cooperation is definitively not a profitable strategy. The existence of cognitive constraints in group cooperation is compatible with the representation of a  $U$ -shaped relationship between transaction costs and group size.

Table 6.10.

*Institutional change and fission–fusion: model predictions and observed behavior*

Type	Model		Observed	
	Condition <sup>(1)</sup>	Prediction	Structures <sup>(2)</sup>	Behavior
Informal	1 $N < \underline{N}$	Informal institution	V	<i>Comfort Zone</i>
	2 $N = N^*$	<i>Optimal group size with informal regime</i>	V	
	3.a $N > \underline{N}$	Transition to a formal institution	V	– Individual adoption
	3.b $N_{\alpha+\beta+\dots} > \underline{N}$	Fusion w/transition to a formal institution	V	– Fusion
Formal	4 $\underline{N} < N < \overline{N}$	Formal institution	V	<i>Comfort Zone</i>
	5 $N = N^{**}$	<i>Optimal group size with formal regime</i>	V	
	6.a $N > \overline{N}$	Fission	V	– Fission independence
	6.b $N > \overline{N} \in [N^{**}, \overline{N}]$	Multi-layer structure ( $n$ layers)	V, C, MV, MCV	– Fission coexistence – Fission clustering – Fission cl. coex.

Note.  $N$ =group size. (1) conditions are numbered and referenced in the description of the model. (2) categories of observed structures refer to *Figure 6.1*. Group size in stand-alone villages under informal institutions is not observable, and therefore communities belonging to this sample are not included in the analyses. Villages, clusters and multi-villages under formal institutions have changes that are *directly observed*, while institutional changes of all the villages under single layer governance and informal institution are *indirectly observed* when a change in the multi-village to which they belong occurs. Graphically, the model works as follows:



Consequently:

*Proposition 1. (Optimal group size).* Given a group of individuals possessing economic rights over a common-pool resource, facing positive transaction costs and constant returns to scale from production, there exists always an optimal group size  $N=N^*$  (cond. 2) that allows the group to achieve the surplus maximization.

***Predictions on institutional changes.*** Two regimes of social interaction in decentralized systems are considered: informal and formal. Informal interaction is based on repeated face-to-face interaction using customs; formal interaction is based on a written contractual agreement. These two regimes correspond to two different collective action problems: the former is direct interaction in resource extraction, while the latter is the participation in institutions for collective action. This regime adoption can be related to group size. Two transaction cost curves are defined for the informal ( $\psi_I$ ) and the formal ( $\psi_F$ ) interaction regimes. Recall that a formal interaction regime is an investment for the group that occurs “once-forever.” This investment does not allow variability in rents from production and allows a higher surplus due to its technological superiority (lower transaction costs).<sup>152</sup> With the adoption of a formal regime, the new aggregate rent level is  $\omega_F > \omega_I$ . The adoption of the formal regime is not profitable when group size is small and occurs when  $\psi_I = \psi_F$ , which also indicates the positive setup cost of a formal regime for the group. This refers to group size at the adoption of a formal regime with  $\bar{N}$  being the size beyond which it is profitable to adopt a legal institution. When transaction costs for the group equal the rent from production, the total rent is eroded; if group size further increases, the group faces a social loss: the maximum group size  $\bar{\bar{N}}$  under the formal regime is

---

<sup>152</sup> In 1398, for instance, Mortaso had, before adopting the first legal institution, a group of insiders that was estimated at 110 individuals. In 1568, after the adoption of the first rural charter, the group of insiders counted approximately 170 individuals.

at  $\psi_F = \pi$ . Hence, optimal group sizes in each regime can be identified:

$$N^* = (\pi^*, \psi_I^*) \text{ and } N^{**} = (\pi^*, \psi_F^*).$$

When  $N < \underline{N}$  (cond. 1), the costs for the transition to a formal regime are higher than under informal interaction. Under this scenario, the optimal choice for the group is to remain informal. When  $N > \underline{N}$  (cond. 3.a), the adoption of a formal regime is convenient and exhibits increasing surplus gains as group size increases. Benefits increase until  $N^{**}$ . In conclusion, the adoption of a formal regime can lead to two gains:

1. transaction costs are further minimized after the adoption of a formal regime:  $\omega_F > \omega_I$  ;

2. formal regimes allow a profitable allocation of property rights in larger groups:  $N^{**} > N^*$  (cond. 5).

a) **Fission**. The fission of the groups, the adoption of a multi-layered structure, or a fusion of two or more groups may be profitable strategies to cope with the exogenous increase of group size.

a.1) *Fission independence*. The point  $\psi_F = \pi$  is critical: at this level, the group obtains no surplus under a formal interaction regime. If the group size increases over this threshold, transaction costs overcome the rent from production and cooperation breaks down in tragedy. Therefore,  $\bar{\bar{N}}$  identifies the upper bound in group size under formal institutions, which is delineated by  $\underline{N} < N < \bar{\bar{N}}$  (cond. 4). When group size is  $N > \bar{\bar{N}}$  (cond. 6.a), it can be profitable for the community to fission into two independent communities (fission coexistence).

a.2) *Fission coexistence*. It is also possible that the leaving subgroup forms more than one subgroup. Until group size is of a size defined as  $N > \bar{N} \in [N^{**}, \bar{\bar{N}}]$  , it

can be profitable for the community to fission into two independent communities (fission coexistence). The fission of a group under a formal interaction regime brings to the formation of two or more groups (the original and the new subgroups originated from the leaving subgroup) and may imply that the original group disappears after the fission if the two new groups decide to become independent (that is,  $A_0$  divides in  $A_1$  and  $A_2$ , and  $A_0$  disappears); the two (or more) new groups may opt for a formal regime or rely on informal interaction, depending on their size.

a.3) *Fission clustering*. Another solution for the group to lower transaction costs at  $N > \bar{N} \in [N^{**}, \bar{\bar{N}}]$  is the split of interactions in two or more clusters (fission clustering) (Archetti, 2009; Lehmann et al., 2007). Such fission may occur both under informal institutions and under formal institutions, and the cause is the increase in transaction costs above an “acceptable” level for the group, corresponding to the entrance into a zone of tolerance. The resulting subgroups may coexist (fission clustering & coexistence), and, in this case, there are groupings of subgroups (clusters). This process can be repeated if a new subgroup increases above  $\bar{\bar{N}}$ .

The result of the fission process can be modeled; however, the model displays unpredictability due to the divergence in the transaction cost structure of the group. The final outcome of the fission for the leaving subgroup is to be placed in a situation where it can obtain a positive surplus, regardless of whether this surplus is below or above the minimal size for adopting a formal interaction regime. In order to occur, this operation must entail an additional cost that is at least offset by the surplus gains in the new situation. Some case studies are useful to complete and clarify the institutional picture.



*Example. Fission.* Consider a group of size  $\bar{N}$  under a formal regime. When  $N > \bar{N}$  (cond. 6.a), the group splits in two equal subgroups of size  $\alpha = \beta = \bar{N}/2$ . Assuming that both subgroups shared the land equally, then each subgroup will have a rent of  $\pi/2$ .

Both groups face the same structure of transaction costs; hence, both groups face the same transaction cost curve. The change in group size causes only a movement on the transaction cost curve: the fission or multi-layered governance affects the rent level but not the structure of transaction costs, provided that the structure of the subgroups is unchanged with respect to the original group. The situation described depicts a case of bargaining under positive transaction costs, which leads to a mutually beneficial institutional change: the leaving subgroup obtains rents in leaving, and the main group obtains rents in allowing the fission. It is assumed that any reorganization of production affecting group size, such as fissioning or the adoption of a multi-layered structure, is performed only if both the leaving subgroup and the remaining subgroup are better off under the institutional change; thus, such a change can be defined as “mutually beneficial.”

*Example. Mutually beneficial fission.* After the fission, the leaving subgroup  $\beta = (\bar{N} - \bar{N})$  returns to a point where it can enjoy a positive surplus. In doing this, it decides whether to adopt a formal institution (if this leads to a higher surplus) rather than relying on informal cooperation. If the leaving subgroup approximates  $\underline{N}$  in the new situation (post-fission), it may enjoy a positive surplus  $A'$  higher than in its previous position. The remaining subgroup  $\alpha = \bar{N}$  benefits from the reduction in size, and it can now enjoy the benefits deriving from the new surplus level  $A$ . The benefit

from the change is measured by  $|A' + A|$ . The model is general enough to also capture the case of an internal fractioning of a community. It is possible to state the following:

*Proposition 2. (Mutually beneficial fission).* Under positive transaction costs, there always exists  $N^{**} < \bar{N} < \bar{\bar{N}}$ , such that at least two subgroups  $\alpha = \bar{N}$  and  $\beta = (\bar{\bar{N}} - \bar{N})$  will both benefit from a fission.

b) **Multi-layered structure.** The adoption of a multi-layered structure follows a fission with clustering at  $N > \bar{N} \in [N^{**}, \bar{\bar{N}}]$  (cond. 6.b) and consists in the reorganization of the original group in one or more dependent subgroups into a “clustered” organizational structure on two or more levels (Zhou et al., 2005). The entitlements over the common land are shared by two or more groups of smaller size that interact within an organizational structure, so that the sum of the transaction costs of the single clusters is lower than in the case of their informal simultaneous interaction.

*Example 3. Multi-layered structure.* Consider a group of  $N=400$  individuals who cannot sustain cooperation. One solution is the adoption of a governance structure in two levels: (i) one group of  $n_1 = 200$  individuals under a formal regime and (ii) two groups of  $n_2 = n_3 = 100$  individuals each under informal interaction. The  $n_2 = n_3$  groups depend on the main group  $n_1$ . The three groups send one representative each to a general assembly, which eventually counts three individuals in total.

The operation exemplified in the case above may appear counterintuitive at first sight, considering that this solution brings additional costs in terms of coordination of the various groups in a new system of assemblies and in terms of multiplication of assemblies. On the other hand, this operation may result in the reduction of transaction costs deriving from interactions that are “cognitively

unsustainable.” The evidence found on cases of fission coexistence, fission clustering, and fission clustering and coexistence is compatible with this example.

c) **Fusion.** Another strategy (alternative to cond. 1) for two or more neighboring groups at  $N < \underline{N}$  is to merge into a larger group to enjoy the benefits of a formal interaction regime in terms of reduction of transaction costs (cond. 3.b). Fusion may occur depending on the distance between the two (or more) subgroups, the cost of transport from one community to another, and the cost of enforcing borders. To this extent, the fusion is exactly the reverse procedure of a fission. Intuitively, the fusion is the first step of institutional change in multi-village organizations. An example can clarify this intuition.

*Example. Fusion.* Consider two communities of size  $\alpha = \beta = N = 100$  under informal regimes. The group merges into a multi-layered community having group size equal to  $N_{\alpha+\beta} = N_{\alpha} + N_{\beta} = 200$  and endowments equal to  $2\pi$ . Assume that both subgroups share the land equally, and if returns on scale are constant and transaction costs decreasing in group size, the two groups may find it beneficial to merge rather than stay independent until  $N_{\alpha+\beta} = \underline{N}$ .

*Proposition 3. (Mutually beneficial fusion).* Under positive transaction costs, assuming  $k = \{\alpha, \beta, \dots\}$  subgroups of equal size and with equal endowments  $\pi$ , when  $N_{\alpha+\beta+\dots} > \underline{N}$  (cond. 3.b), it is always profitable for the communities to formally merge in a larger group with larger endowment  $\kappa\pi$  in order to enjoy the benefits of a reduction in transaction costs and an increase of the aggregate surplus after the fusion.

Table 6.10 summarizes in tabular form the decisions a group may face in solving the collective action problem to achieve surplus maximization and accommodate cognitive limits under the model’s predictions. The other two columns

on the right show how the observed structures and behavior in the data are represented by the model's predictions. The general conclusion that can be drawn from the model is as follows: a group will proceed to institutional change only when the surplus obtainable is higher than under the previous institutional choice (Alchian & Demsetz, 1972; Demsetz, 1967). According to the model, a formal interaction technology is convenient when it allows an increase of the aggregate surplus attainable by the group and to manage a larger group size. Similarly, it is also shown how fission–fusion behavior may be interpreted as institutional changes profitable in economic terms. The potential for economic benefits deriving from these changes may explain why they are observable in nature.

#### **6.4. Conclusions**

This chapter started from the observation of fission–fusion behavior and group size in a selected sample of multi-village communities, and the economic and legal rationale underpinning the behavior was examined. The internal organization of these multi-villages was detected and reconstructed, although the proxy used for group size had some inevitable limitations concerned with the measurement of the real size at which the group solves face-to-face collective action.

It was found that collective action is internally structured in subgroups organized in no more than four organizational layers (Figure 6.1). When comparing the population of face-to-face units in multi-village organizations with the population of a control group of stand-alone villages at the last institutional change, it was found that the median is not statistically different in the two groups. The median population of the stand-alone group remains basically unchanged from the first until the last institutional change ( $M_F=M_L=306$ ,  $IQR_F=528$ ,  $IQR_L=566$ ,  $N_F=N_L=76$ ), while the median population of the face-to-face units is significantly higher. These facts can be

explained by the existence of a relation between human cognitive limits and institutional change. Such cognitive limits are naturally present in our information processing capabilities and therefore affect our capacity to solve problems and to transact efficiently in collective action settings. The adoption of a fission–fusion strategy allows the overcoming of these limits by means of an efficient internal structure. This argument has been used in this chapter to suggest the applicability of the threshold hypothesis to the field of economic institutions and organizations.

It was found that the process of institutional change follows a pattern repeated in all the case studies: fusion, fission coexistence, clustering, clustering and coexistence, independence. Institutional changes (specifically, fission) were not a sudden one-step choice for the group, but occurred through gradual transformations. It was conjectured that these changes are in sequence ordered by increasing transaction costs (Figure 6.6–6.7): this conjecture was supported by the observation of institutional changes entailing low transaction costs and repeated in sequence with high frequency (fission coexistence), alongside changes with high transaction costs repeated in sequence at a lower frequency (fission independence). Accordingly, if a relation exists between institutional change and group size, these changes should be sorted also by decreasing group size order.

In an analysis of the relation between the size of multi-villages and of the largest cluster after every fission event, the hypothesis finds empirical support. The different types of fission events identify a spectrum where independence is adopted by smaller multi-villages up to ~ 1,000 inhabitants, clustering (including clustering and coexistence) occurs up to ~ 6,000 inhabitants, while coexistence occurs along the whole population size spectrum in multi-villages up to ~ 9,000 inhabitants. The size of the largest cluster (village) varies between 102 and 6,259 inhabitants.

After organizing the data according to systematic coding, and after analyzing the data, a simple model was elaborated to provide an economic interpretation of the findings. When group size increases exogenously, if rents from productions are kept optimal in perpetuity, institutions adapt to minimize transaction costs in order to maximize the aggregate welfare from the common-pool resources. The transition from an informal to a formal institution and the fusion or the fission of the group are modeled as transaction cost minimization choices. The adoption of an internal structure through fission–fusion strategies can be a solution to overcome the limit imposed by transaction costs in collective action.

This study has four main limitations. The first stands in the limited number of observations on which it bases its claims. The second is that the analysis of fission and fusion behavior could be based only on the observation of villages belonging to formal multi-village organizations, because institutional changes were reported in written documents. This study cannot exclude the occurrence of fission and fusion behavior also in informal multi-village organizations, which remain unobserved. The third is that population almost tripled between 1200 and 1800, and this might explain why fission events were observed more frequently than other institutional changes. Fourth, the interpretation of the results is based on the assumption that population growth was exogenous to the process of institutional change. Although this assumption is plausible (Black & Henderson, 1999; Kremer, 1993), further research on new data will be able to clarify the direction and degree of causality between institutions, population, and economic growth.

## Chapter 7: Defining Heterogeneity and Institutional Design

*Two neighbours may agree to drain a meadow, which they possess in common; because 'tis easy for them to know each other mind; and each must perceive, that the immediate consequences of his falling in his part, is the abandoning the whole project. But 'tis very difficult, and indeed impossible, that a thousand persons shou'd agree in any such situation; it being difficult for them to concert so complicated a design, and still more difficult for them to execute it; while each seek a pretext to free himself of the trouble and the expense, and wou'd lay the whole burden on others. Political society easily remedies both these inconveniences.—(Hume, 1739)*

### 7.1. Introduction.

This chapter introduces the conceptual framework for the empirical investigation of institutional design carried out in Chapter 8. The focus is on the relationship between group and resource heterogeneity and the design of institutions for the management of common-pool resources. This study defines the concept of heterogeneity, outlines the main achievements, limitations and gaps in the literature.

This chapter starts by providing an account of the recent scholarly interest for the study of the effects of appropriators' heterogeneity on the likelihood of self-organization and the design of rules (Ostrom, 2005). The next chapter investigates empirically whether heterogeneity was a key determinant of the institutional design, stability and change in the *Carte di Regola* system. The final section of this chapter provides a graphical description about how the present author proposes to contribute to the scholarly debate.

## 7.2. The Relevance of Heterogeneity

**7.2.1. Definition.** As a first approximation, group heterogeneity may be defined as referring to existing differences across the group's observation units. Unlike group size, which has a very intuitive measure (counting individuals in relation to a universal scale), heterogeneity must be expressed in relation to a measured "dimension" (i.e., group A and group B differ in terms of index  $x$ ), resulting after the implementation of a "methodology" considered suitable to measure the difference along the chosen dimension (i.e., when index  $x$  is computed with method  $j$  on groups A and B, group A is more heterogeneous than group B because  $x_A > x_B$ ). The emphases of the literature can hardly be limited to only one of these aspects.

In recent decades, an increasing number of papers on heterogeneity in collective action tackled either the dimensions of heterogeneity (for instance, cultural backgrounds, interests, and endowments: Baland & Platteau, 1996; Ostrom, 2005), or the methodology (for instance, fractionalization or polarization: Alesina, Devleeschauwer, Easterly, & Kurlat, 2003; Esteban & Ray, 1994; Montalvo & Reynal-Querol, 2003), or both (Alesina, Devleeschauwer, Easterly, & Kurlat, 2003; Esteban & Ray, 1994; Montalvo & Reynal-Querol, 2003; Leeson, 2005; Ostrom, 2005). Normally, these contributions are attempts to disentangle the consequences of heterogeneity on economic outcomes.

More recently, a branch of this literature has been concerned with the resilience of institutions for the management of common-pool resources. The contributions on this issue—differing in methodologies, geographical scope, sample sizes, and periods of observation—often report contrasting results and highlight a substantial disagreement among scholars. An example of this disagreement concerns precisely the role of heterogeneity and group size in collective action. Heterogeneity



and group size are expected to have an influence on collective action; however, scholarly consensus breaks down on the precise nature of their relationship and on the relative importance of either factor.

Part of the problem is theoretical: the lack of agreement is on their conceptualizations (i.e., how to classify group size and sorting out sources of heterogeneity) often being misspecified (Ostrom, 2005). A second group of problems is on the empirical side and is inevitably related to the theoretical impasses (i.e., isolating the influence of either factor when they are interdependent and interrelated with several other variables: Poteete & Ostrom, 2004). Although it is generally thought that an increase in group size and heterogeneity is accompanied by an increase of transaction costs, which have an impact on the way public goods are provided (Barros, 2008), no definitive answer has thus far been provided as to whether and how group heterogeneity may have an impact on the design of institutions for the management of the commons.

**7.2.2. Heterogeneity in institutions.** The study of heterogeneity and of its consequences in collective action and institutions has a long scholarly tradition, being separately treated in two strands of research and predominantly dealing with the determinants of the provision of public and collective goods.

The first strand of studies moved from the theoretical study of collective action (Heckathorn, 1993; Oliver et al., 1985; Olson, 1965), later inspiring literature on common-pool resources. The groundbreaking study by Ostrom (1990) on the governance of the commons explicitly uses the expression “institutions for collective action,” first raising the problems of size and heterogeneity in self-governing groups managing common-pool resources. There have been numerous contributions following this first study, which are only outlined here.

A further stream of literature commenced with Tiebout (1956) and has been developed in the works of Alesina, Easterly, and Baqir (1999) and Alesina and La Ferrara (2005). Such contributions inspired scholars interested in economic growth and the effects of inequality, fractionalization, and inter-group conflicts on institutional and economic outcomes (Acemoglu, Johnson, & Robinson, 2001; Alesina et al., 2003; Easterly, 2001; Habyarimana, Humphreys, Posner, Jeremy, & Weinstein, 2007; Vigdor, 2004); these have been followed by a rich body of both theoretical and empirical papers, and—more recently—experiments (Smith, 2011).

The leading question in the study of common-pool resources (i.e., forest, pasture, water basins, the atmosphere, etc.) has recently shifted to research on the effects of the heterogeneity of appropriators on the likelihood of self-organization and the type of rules designed (Ostrom, 2005). Contributions in this strand of literature differ in their definition of group heterogeneity along a diversity of dimensions. For instance, Vedeld (2000) focuses on resource heterogeneity, particularly forest coverage. Varughese and Ostrom (2001) highlight the terms of the institutional consequences for the presence of heterogeneity: when the interests of appropriators differ, it is particularly challenging to achieve a self-governing solution to common-pool resource problems. One study of particular interest for our analyses—also often quoted by Elinor Ostrom, among many others, when reporting the issue of heterogeneity—is Lam's (1998) study performed on 150 farmer-governed and agency-governed irrigation systems in Nepal. Lam investigated the impact of several variables on three performance proxies: physical condition of irrigation systems, quantity of water available to farmers at different moments of the year, and agricultural productivity of the systems. The use of multiple regression allowed Lam to control for environmental differences (read: resource heterogeneity) among

systems. The model specifications contained several factors, including the physical size of the resource system, terrain characteristics, and number of farmers. The strongest impact, however, was identified in the form of the governance system. In particular, it was found that irrigation systems self-governed by the farmers themselves performed significantly better than the agency-governed ones on all three performance indexes (Lam, 1998; Poteete et al., 2010).

The problem is often raised of appropriators with more economic and political assets having similar interests to those with fewer, which may also differ substantially.<sup>153</sup> Ostrom (2005) reviews a series of case studies of interest dealing with economic inequality, related to income, assets, stability of income streams, values, knowledge and skills, and location, in maintaining the resource. Ostrom also reviews studies dealing with forms of social heterogeneity (age, gender, ethnicity, status, and residence), which often are mirrored in forms of political and economic heterogeneity at the base of a group's interests in shared resources (Poteete et al., 2010). Across all of the studies reviewed by Ostrom, heterogeneity usually has an impact on collective action, yet occasionally does. When it was present, heterogeneity had a highly variable impact.

Despite the case studies reported by Poteete et al. (2010) showing that institutional arrangements can mitigate the effects of heterogeneity, it is usually regarded as an obstacle to collective action, because it hinders individuals from reaching cooperative solutions (Bandiera et al., 2005; Libecap, 1995) and is seen as negatively affecting the quality of institutions (La Porta, Lopez-de Silanes, Shleifer, & Vishny, 1999). This argument highlights a major concern within the literature on heterogeneity (Ostrom, 2005), that the direction of causality remains uncertain.

---

<sup>153</sup> See Bandiera et al. (2005) for a review of evidence from field studies and from an individual level panel dataset of rural workers in a farm in the UK.

This uncertainty is in part due to the existence of endogeneity in the process of institutional formation: when the researcher observes institutions, it is indeed very difficult to determine cause and effect. A common problem bringing researchers to false inferences is making empirical statements affected by “reverse causality”; that is, affirming that  $A \rightarrow B$  is not statistically significant when, in reality,  $A \leftarrow B$  is perhaps statistically significantly. An example relevant for the present study is the understanding of the direction of causality in the relationship between heterogeneity and institutions (Aoki, 2007): do good institutions cause less heterogeneity, which causes economic outcomes, which in turn affect those institutions? Alternatively, is less heterogeneity causing good institutions, which cause economic outcomes, which in turn affect heterogeneity (Leeson, 2005)? The answer to these questions is of key importance for anyone taking the challenge of first defining and then measuring institutions, as Voigt wisely points out in a recent debate that appeared in the *Journal of Institutional Economics* (Robinson, 2013; Shirley, 2013; Voigt, 2013a, b). The challenge tackled in the next chapter is to investigate whether a relation from heterogeneity to features of institutional design can be defended on theoretical and empirical grounds.

### **7.3. The Relevance of Institutional Design**

**7.3.1. Robust institutions.** Before exploring the potential consequences of heterogeneity on institutional design, the type of institutions studied in the present context, as well as the dimensions along which they differ from those reported in other studies investigating the same relation, need to be specified.

The institutions observed can be generically defined as “robust,” where robust is intended as a synonym for “good.” According to Leeson (2005), two approaches have emerged in the study of why economic progress is linked to institutions

(Acemoglu et al., 2001; Acemoglu & Johnson, 2005). The first supports the existence of a causal link from heterogeneity to bad institutions and to poor economic performance (Alesina et al., 1999; Alesina et al., 2003; La Porta et al., 1999; Levine & Easterly, 1997). The second, and more recent (Easterly, 2001; Leeson, 2005), asserts that bad institutions lead to heterogeneity and, consequently, to poor economic performance. Leeson, quoting Easterly (2001), emphasizes the “importance of institutions in mitigating the problems typically associated with fractionalization” (p. 76). In the case studied by Leeson, “heterogeneous agents in pre-colonial Africa relied on social distance-reducing signals to make trade with one another possible” (p. 77). Leeson shows “how colonial institutions created noise in these signals, inhibiting widespread cooperation” (p. 75), and one of the main claims in the paper is that heterogeneity does not lead necessarily to “bad” institutions and poor economic outcomes: “What matters for progress is the ability of individuals to realize the gains from widespread exchange” (p. 76). Since finding generically good institutions might be at least questionable, for the purpose of the present study, institutions defined as good are those that satisfy the eight design principles for robust CPR (Common-Pool Resources) institutions identified by Ostrom (1990):

1. Clearly defined boundaries
2. Congruence between appropriation and provision rules and local conditions
3. Collective-choice arrangements allowing for the participation of all or most of the appropriators in the decision-making process
4. Effective monitoring by monitors who are part of or accountable to the appropriators
5. Graduated sanctions for appropriators who do not respect community rules

6. Conflict-resolution mechanisms that are cheap and easily accessed
7. Minimal recognition (e.g., by the government) of rights to organize
8. In case of larger CPRs, organization in the form of multiple layers of nested enterprises, with small, local CPRs at their bases. (Ostrom, 1990, p. 92)

Bottom-up institutions are observed, and the “goodness of institutions” from the above characteristics but also from their actual institutional outcomes is inferred. The first institutional outcome (and the more easily observable) is identified in the “endurance” of the institution, which may be considered an index of robustness grounded in the feasibility of long-term social cooperation. The second outcome is “sustainability,” where the commoners are able to overcome the potential tragedy of the commons and are able to use the resource at a sustainable rate (i.e., avoiding depletion). A more precise definition of sustainability would require the direct observation of welfare effects of these economic choices, but when these are not observable, it is necessary to roughly approximate endurance with “economic sustainability.”

**7.3.2. Institutional design.** Chapter 8 will investigate empirically whether heterogeneity is a key determinant of the institutional design, stability, and change in the *Carte di Regola* system. This subsection, instead, defines the extent to which the heterogeneity and institutional design are theoretically connected.

Although in a very different context from that of contemporary democratic constitutions, these historical institutions replicate on a wider timeframe analogous present-day political and legal situations. How formal institutions change, and in particular the type of constitutional changes a society might undergo—whether amendments or replacements—has been the object of a recent inquiry on the

determinants of constitutional change in 20th century Latin America, as opposed to constitutional stability (Negretto, 2012). On this point, Negretto puts forward and tests two main arguments relevant to the purpose of this chapter: "...constitutions are replaced when they fail to work as governance structures or when their design prevents competing political interests from accommodating to changing environments" (p. 749) and "...the frequency of amendments depends both on the length and detail of the constitution and on the interaction between the rigidity of amendment procedures and the fragmentation of the party system" (p. 750).

Even though the *Carte di Regola* cannot be defined properly as "constitutions" and are certainly very different from contemporary constitutions, these cases of self-governance constitute an ideal empirical setting for observing the determinants of institutional design, given their extraordinary endurance. The theoretical problem at the root of this chapter has been long debated in political theory, as shown by the passage by David Hume (1965) quoted at the beginning of this chapter. The excerpt focuses on the conditions that allow successful collective action in a common-pool resource situation and raises the Olsonian argument that "large groups will fail" more than two centuries before Olson (1965).

While devising the problem of public good provision, this passage suggests that a large group size has consequences in the formation of collective agreements. This problem, despite the abundant literature produced in recent years, is still regarded as a theoretical and empirical challenge (Ostrom, 1990; Poteete & Ostrom, 2004, Ostrom 2010). Hume granted to political society alone the merit of providing solutions to solve collective action problems: history demonstrates that large groups are also able to avert the tragedy of the commons by writing their own covenants (Ostrom et al., 1994). However, a less restrictive reading of the excerpt is compatible

with alternative solutions when Hume posits their existence as conditional on “complicated designs,” difficult to be agreed upon, and of difficult enforcement.

In addition, Wade (1988), in his analysis of southern Indian village institutions, cites Hume and highlights the importance of heterogeneity of preferences as a factor influencing the design of “from within” solutions to collective action:

It is also intuitively clear that if a group contains diverse preferences about how much of the public good should be supplied (how thoroughly the meadow should be drained, in Hume’s example) it may be difficult to reach a consensus. Yet there can be only one level of supply in the case of a public good, so a consensus must somehow be reached. Where there are more than a handful of individuals whose preferences must converge, the transaction costs of obtaining the agreement may be high. Even if there was perfect consensus the free rider problem would remain; but the need to reach consensus adds to the difficulties facing any group or potential group that would provide itself with public goods. (Wade, 1988, p. 16)

Wade’s statement is susceptible of being generalized as a story of transaction costs: a group of individuals gathered in legislative assemblies where interaction through discussion and direct vote is possible, at different costs of attaining and sustaining an agreement, can be considered as a typical example of collective action in institutions. Large groups face the risk of failure in reaching consensus over a certain course of action, and failure is seen as a consequence of unsustainable transaction costs in a large group or of the impossibility of aggregating individual preferences.<sup>154</sup>

---

<sup>154</sup> See relevant parts in Chapter 5.



#### 7.4. Conceptual Framework

The present section describes the plan to tackle the analysis of the effects of heterogeneity and size on institutional design in the next chapter.

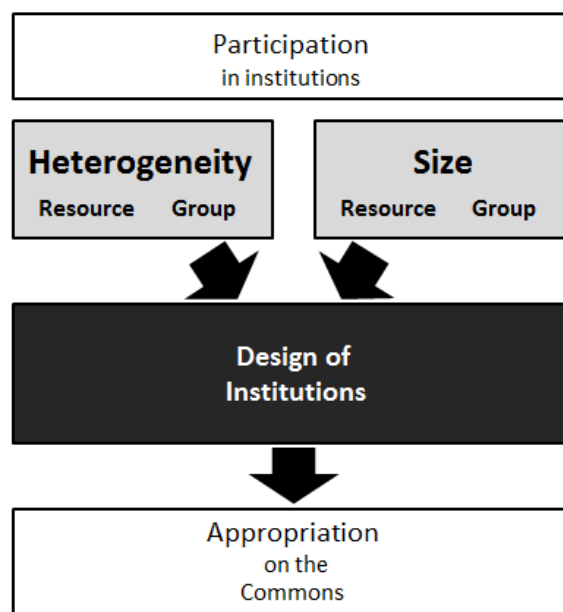
The framework described in Chapter 1 (Figure 1.1) adopts only one of the possible research paths in studying the issue. Here, only a specification of the framework is presented, which has the following characteristics. First, the analyses are limited to formal institutions, despite the awareness that group size and heterogeneity are also relevant under informal institutions: this limitation is caused by the availability of data only for formal institutions. Second, exogenous population growth is posited, and heterogeneity is also modeled as independent of institutional outcomes. Third, the context is limited both in terms of the field of application and the territory: the community management of the commons in the Italian Alps from 1245–1801 is studied. Fourth, the study of heterogeneity is limited to only two of the possible dimensions: social and resource heterogeneity.

The conceptual map in Figure 7.1 represents the participation of the group to building institutions as affected by some dimension of resource and social heterogeneity. Participation is also affected by a second characteristic: the size of the resources of which the community is endowed, and an index of the numerosity of the individuals called to decide the destiny of the institution and of the community. The direct appropriation of common resources is then “mediated” by an institution written by the group, which is modeled as necessarily dependent on the design of the institution. The design of institutions is modeled as determined by group heterogeneity and size.

## 7.5. Conclusions

The purpose of this chapter was to introduce the reader to an issue of utmost relevance in institutional analysis: the definition and the effects of group heterogeneity and the design of institutions.

More specifically, this chapter provided a definition of heterogeneity and presented the main problems raised in the literature according to its measurement and its interpretation.



*Figure 7.1.* The framework: group size and heterogeneity.

A separate section provided a focused literature review on heterogeneity and of its consequences in collective action and institutions.

In Section 7.2, institutional design was defined in relation to the specific type of institutions analyzed in this study. Ostrom's requirements for robust CPR institutions were recalled. The section highlighted the way in which the literature implicitly identified heterogeneity as an important variable in the study of the institutional design of successful institutions, and also underlined a literature gap

concerning the consequences of heterogeneity on institutional design in the study of self-enforcing institutions for the management of the commons.

Section 7.3 illustrated how a specification of the framework may provide one research strategy in studying the issue. The next chapter will develop the strategy and propose the empirical study of the effects of group heterogeneity and size on the design of institutions.

## Chapter 8: Effects of Group Heterogeneity and Size on Institutional Design

*An institution is defined as collective action in control, liberation and expansion of individual action. Its forms are unorganized custom and organized going concerns. The individual action is participation in bargaining, managing and rationing transactions, which are the ultimate units of economic activity.*—(Commons, 1931)

### 8.1. Introduction

**8.1.1. Background.** This chapter is concerned with the effect of social and resource heterogeneity on the process of institutional design and, ultimately, on institutional change. This study conjectures that factors pre-existing collective action might influence the institutional decision process. As a consequence, institutional design may vary in response to changes in group characteristics (Williamson, 1979). Differences in institutional design, for example, can be related to differences of transaction costs in groups that are heterogeneous. Two dimensions of this heterogeneity are here explored: social and resource heterogeneity.

In the specific context of the *Carte di Regola*, heterogeneity is seen as a factor that increases the costs of social contracting for the allocation of property rights, decreases the likelihood of social cooperation, and hinders the process of aggregation of individual preferences in the provision of public goods. The aggregation of preferences is made difficult by increasing heterogeneity. When transaction costs are positive, institutions emerge to allocate property rights and attain the maximization of the surplus from production.<sup>155</sup> Institutions for property rights react to differences in

---

<sup>155</sup> On transaction costs and the “Coase theorem,” read Coase (1960). Useful references on the process of allocation of property right are Libecap (1989); Libecap (1995); Barzel (1997). On the role of group composition, transaction costs, and social cooperation, recent studies have been written by Smith (2011); Erlei (2008). Classic references on aggregation of social preferences are always Arrow (1950); Brown (1975). The impact of heterogeneity on public good provision has been investigated by Alesina et al. (1999); Vigdor (2004); Habyarimana et al. (2007).

transaction costs in their evolution path by engaging in benefit-driven “institutional changes” that potentially affect institutional design (Acemoglu & Johnson, 2005; Demsetz, 1967; North, 1990). Recent research in constitutional economics implicitly supports this research strategy: sources of societal heterogeneity are found to affect the structure of constitutions and the normative content of the rules written and enforced by decision bodies involved in collective action (Bandiera et al., 2005; Barros, 2008; Crowley, 2011).

Using multiple regression analysis, this chapter combines a comparative analysis of institutions (Greif, 1998, 2006) with the statistical analysis of individual- and community-level data from multiple historical and geographical sources (Diamond & Robinson, 2010). The present study focuses on 159 self-governing communities that wrote and voted on community bylaws to manage their common resources.<sup>156</sup> The assemblies observed in this chapter took place at different times in the Trentino region over six centuries (1245–1801). Several proxies of institutional complexity are developed, based on a body of 260 charters comprising 8,994 coded articles. Individual-level data about 7,765 attendees offer details on the village assemblies that approved the bylaws. Data on community surface estimates are obtained from the 1897 Land Register.

The dataset used in this chapter delineates a robust institutional setting and exhibits the following advantages: long timeframe of observation (six centuries); well-delimited region with a stable central political power throughout the period and heterogeneous environmental characteristics (Alpine area); similar institutions (the *Carte* system) of different types (complete charters, amendments, or other related documents).

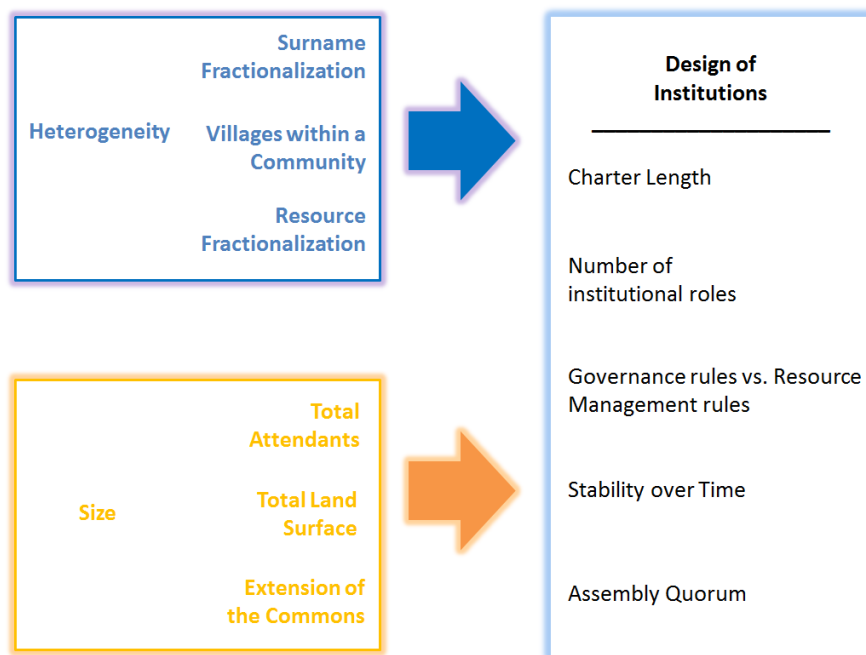
---

<sup>156</sup> For a detailed description of the dataset and of the sample, please refer to Section 3.3.4.

This chapter is organized as follows. The present section continues with a subsection containing a description of the research strategy. Measures, statistics, and econometric methods are described in Section 8.2; Section 8.3 presents and discusses the results of the statistical analyses; and Section 8.4 offers a summary and conclusions.

**8.1.2. Research strategy.** The sources of heterogeneity are separated from other characteristics of the community that are arguably exogenously determined and preexistent to the assembly (“before”). Institutional outcomes are modeled as dependent on these factors (“after”). This choice will be discussed in the section dedicated to the econometric model and has important empirical consequences. For instance, it allows the minimization of potential endogeneity issues that could emerge when estimating the effects of heterogeneity and size on institutional features: techniques often used to deal with endogeneity, like time lags or instrumental variables, are not necessary in the present context (Aoki, 2007; Crowley, 2011; Leeson, 2005).

Figure 8.1 maps the components of the research design: group and resource heterogeneity, group and resource size, and institutional outcomes. The empirical analysis will consist in the testing of a series of statements concerning the possible effects of variables on the left-hand side of the pictogram (“heterogeneity” and “size”) on variables contained in the box on the right (“design of institutions”).



*Figure 8.1.* Research design.

Two dimensions of group heterogeneity are here identified: social heterogeneity and resource heterogeneity. Social heterogeneity is measured by the diversity of surnames in the group of the attendants to the assemblies. Measures of social heterogeneity based on surnames are controversial, and the conditions for the use of this proxy are illustrated in Section 8.2. Resource heterogeneity is measured as the diversity of resource endowments within a community. For example, consider two communities having both forest and pasture: in one, there is a prevalent resource, while in the other, a different resource is prevalent.<sup>157</sup> Both social and resource heterogeneity, and group size, are assumed to exist before the assembly takes place.

Institutional design can be defined as a “process aimed at producing prescriptions, organization charts and plans, usually with some adaptive rules for coping with unforeseen circumstances” (Olsen, 1997). It can be reduced to a number

<sup>157</sup> A set of variables also indicate the size of the community: the number of attendants, the total extension of productive land, a control for high commons endowments.

of key “institutional features” considering the normative content of the new institution in terms of structure and content. These characteristics are represented by a number of variables and are assumed to deploy effects after the assembly takes place.

**8.1.3. Research design.** The empirical strategy implies four restrictions.

First, heterogeneity is measured using fractionalization indexes. Other indexes have been used in other studies to measure conflict or inequality (for which other indexes like the polarization index used by Esteban and Ray, 1994; Garcia-Montalvo and Reynald-Querol, 2002; Montalvo and Reynal-Querol, 2003, or the Simpson’s index, Gini index, or measures of entropy are usually employed). However, since the present interest is on group fragmentation, the fractionalization index, used for example in Alesina et al. (2003), seems best suited. This issue is addressed in Section 8.2. This choice has a number of consequences. For instance, one is that we are bound to studying diversity of groups in probabilistic terms, regardless of other measures of group heterogeneity, like conflict, economic inequality, and entropy.

A second characteristic of this study is that the scope of heterogeneity is limited to social heterogeneity and resource heterogeneity. The present author is aware that other dimensions could be explored, and the data available offered the potential of studying only a limited set of information.

Third, heterogeneity is modeled as exogenously determined and independent of institutional features. The endogeneity between fractionalization and other variables is a potential limitation introduced by the choice of measuring heterogeneity using surnames. This issue will be discussed in detail in Subsection 8.2.2.

Fourth, all the assemblies are initially considered as separate and independent observations, even when occurring in the same community at a different moment in time, regardless of the possible effects of internal migrations and endogenous



population growth. The econometric estimates presented in Section 8.3 instead are designed to capture the effect of time and are corrected for potential arbitrary serial correlation among observations of the same community.

The analyses conducted in this chapter hold under the hypothesis that the subset of 260 documents is representative of the whole set of charters. Potential self-selection issues are addressed by assuming that the notary decided to write the list of attendants at random. Direct evidence was not found of notarial regulations setting forth provisions requiring the notary to write down the lists of attendance. Local historians and archival experts on notarial deeds confirmed that there was no explicit legal burden on notaries in this sense: hence, randomness in reporting the list of attendance can be assumed. Support for this assumption consists of three facts: the dataset covers six centuries (1245–1801); it is possible to find both very long and very short lists for both small and large meetings; and the lists were written in diverse natural settings. The following section discusses the methods employed in building each specification, their limitations, and the theoretical and empirical implications of their use.

## **8.2. Methods**

The present section describes the methods used to build the variables employed in the empirical models and discusses their limitations. Eventually, the main estimation equation used to identify the effects of social heterogeneity and resource heterogeneity, and of group size on institutional features, as represented by the estimation framework, is presented and discussed.

**8.2.1. Social heterogeneity.** Measures of social heterogeneity differ along the dimensions considered by different authors, mainly conflict and fragmentation; however, there is no consensus as to which universally captures the phenomenon.

Here, an index to measure social fragmentation using surnames is employed. The formalization of the index is based on the ethno-linguistic fractionalization (ELF) index (Alesina et al., 1999; Alesina et al., 2003; Garcia-Montalvo and Reynald-Querol, 2002); this index has theoretical and practical limitations of surname fractionalization. The results obtained from historical data were eventually compared with simulated data.

Among the vast repertoire of indexes retrievable in the literature, measures of ELF represent in an intuitive way how much a society is “fragmented” (technically, “fractionalized”). The index works on the concept of “probability”: social fractionalization is high when the probability that two randomly selected people from a population  $N_a$  come from different groups is proximate to the unit. In its mathematical formulation, the ELF index is analogous to the Hirschman–Herfindahl index (Hirschman, 1964). The Hirschman–Herfindahl index is widely applied in competition law and antitrust to measure market concentration and is computed as the sum of the squares of the market shares of the 50 largest firms: the market shares are expressed in fractional form. The index used in the present study works as follows.

Consider an assembly with  $N$  members. The number of assembly members with surname  $j$  (or belonging to any group  $j$ ) is  $N_j$ . The index of surname fractionalization for each of the assemblies is computed as:

$$h = 1 - \sum_j \left( \frac{N_j}{N} \right)^2 \quad (8.1)$$

Let  $\pi_j = N_j / N$  be the fraction of the population in group  $j$  or the probability that a randomly selected person from the population belongs to group  $j$ . This index measures the probability that two randomly selected individuals from the population

come from different “surname groups” (“families”). The readability of this index can be improved with some algebra:

$$h = 1 - \sum_j \pi_j^2$$

$$h = \sum (\pi - \pi_j^2)$$

$$h = \sum_j \pi_j (1 - \pi_j)$$

The surname fractionalization index can be finally rewritten as

$$h = \sum_j \pi_j (1 - \pi_j) \quad (8.2)$$

When surnames are all equal, there is perfect homogeneity:  $h = 0$ ; when surnames are all different, there is perfect heterogeneity:  $h = 1$ . If the population is split into two identical groups,  $h = 1/4$ .

***Measuring social cohesion using surnames.*** Surname fractionalization has been measured at the assembly level, using all of the attendants’ surnames within the assembly dataset. The index, originally referred to the assembly, has been interpreted as referred to the community where the assembly took place.<sup>158</sup> Surnames were considered an appropriate dimension to calculate an index of social fractionalization in assemblies, and there are practical and theoretical reasons for this choice.

From a practical standpoint, the analysis of social heterogeneity is limited to availability of the data retrievable in the sources (surnames and the composition of the

---

<sup>158</sup> Surnames have been distinguished from other individual identifiers (such as nicknames, job titles, etc.) in the lists of attendance and translated and attributed a unique code to enable the within-assembly comparison of surnames with the aid of Cesarini Sforza (1914). In his work, Sforza divides the origin of surnames into the following classes: 1. Women; 2. Arts, jobs, professions; 3. Physical qualities, body parts; 4. Moral qualities; 5. Objects; 6. Places; 7. Animals; 8. Plants; 9. Food; 10. Others. The goal was to distinguish real surnames from other individual attributes among the classes listed in the book. Efforts have been made to allow cross-assembly comparison of surnames using string distance minimization algorithms when attributing the unique codes: The results are not reported in this chapter, as for the purpose of these analyses it was relevant only to distinguish whether each surname was equal to or different from the surnames of all the other attendants.

260 assemblies). Out of the 7,765 individuals, there are 3,317 different surnames. In these assemblies, there were, on average, two surnames; however, this figure ranged from a minimum of 1 to a maximum of 10.<sup>159</sup> The unit of observation for social fragmentation is the single assembly. Among the 260 assemblies, 252 had a number of attendants included between a minimum of 2 and a maximum of 295 attendants.

From a theoretical point of view, surnames are considered to contain information on the genetic traits of populations (Jobling, 2001; King & Jobling, 2009) and have been used in anthropology, biology, and genetics to study family structures in history (Bowden et al., 2008; Guglielmino et al., 1996), migration (Colantonio, Lasker, Kaplan, & Fuster, 2003), the extinction of families (Watson & Galton, 1875), inbreeding rates (Darwin, 1875; Lasker, 1977), genetic isolation, and distances between populations (Colantonio et al., 2003; Sella et al., 2010).

A criticism related to the use of indexes based on surnames concerns the transmission of the surname from father to son. A perhaps more accurate reconstruction of the genetic transmission could be achieved if the surname were the mother's, while in patriarchal societies, the surname represents information on only half of the genetic heritage. For instance, two attendants could (a) have different surnames and yet be first cousins as their mothers are sisters or (b) have the same surname and yet not be related at all. In our case, this criticism has a limited scope when referred to the first example. It is assumed, for simplicity, that the interests of households having a different surname are independent and not identical. Consequently, two individuals having a different surname represent the interests of two different households: in fact, only the heads of the households could attend and vote at the assembly. The criticism also has a limited scope in situations analogous to

---

<sup>159</sup> Source: own calculations by the present author from the assembly dataset.

the second example: the small size of villages and the need to close the community to access to the commons by outsiders resulted in high inbreeding rates, as reported in the case of the Valley of Non and of other Alpine villages.<sup>160</sup> Thus, it is more plausible than not that, in this study, two identical surnames referred to the interest of the same family.

Surnames in assemblies are treated as competing “parties.” In this sense, surname fractionalization indicates the fragmentation of the assembly and also the genetic distance of the population (Ahlerup & Olsson, 2012).

Table 8.1.

*Surname fractionalization: summary statistics*

Variable	Mean	Std. Dev.	Min.	Max.
Surname Fractionalization	0.875	0.095	0.34	0.991
Total attendants	31.244	29.679	2	295
N		258		

***Properties and limitations of the surname fractionalization index.*** Three properties of the surname fractionalization index are described in this subsection, and their implications in the interpretation of the index, and resulting limitations in the empirical analysis, are considered.

Although extremely versatile in its potential applications, it is found that the index, in its general form, may suffer from a number of limitations when applied to measuring fractionalization based on surnames in the case under analysis. The summary statistics of surname fractionalization and the number of assembly attendants are in Table 8.1.

<sup>160</sup> See, for instance, the studies by Cole and Wolf (1999); Gueresi, Pettener, and Martuzzi Veronesi (2001); Gueresi, Martuzzi Veronesi, and Pettener (1994); Prost, Boëtsch, Girotti, and Rabino-Massa (2008); Sella et al. (2010); and Viazzo (2006).

The larger the assembly and the larger was the surname fractionalization index. The correlation between surname fractionalization and the number of assembly attendants is 0.5141.<sup>161</sup>

The first feature of the surname fractionalization index is that it does not specify controls for the size of the group  $N$ . It provides a “standardized” measure of social fragmentation and assumes that the populations that the index is computed for are equal in size. In other words, the nature of this index is to represent the probability of the event “two random draws belong to different groups” and is based on the proportion of each family (where a family is the number of people sharing the same surname in the assembly) over the total population observed in the assembly, not on their actual size. This measure does not allow consideration of social fragmentation independently of the effect of group size, and this is a limitation in the specific case under analysis.

The second feature is that the fractionalization index measures fragmentation and not the effect of conflict and distance within groups. The reader may think of many examples where the fractionalization index is capturing the wrong relationship. One such example might be the effect of heterogeneity on conflict. Measures of “polarization” are usually preferred in these cases. For instance, the measure of polarization in Esteban and Ray (1994) formalizes the idea that cooperation is more difficult to achieve in two large groups than in many small groups. Analytically, the fractionalization index can be considered as a particular case of a more general polarization index employed to measure social heterogeneity observing group conflict. The main difference with a polarization index (Esteban & Ray, 1994; Garcia-

---

<sup>161</sup> Table 8.4, Appendix D.

Montalvo & Reynald-Querol, 2002) is that fractionalization assumes that differences between groups are all the same (Banerjee, Iyer, & Somanathan, 2008).<sup>162</sup>

A more sophisticated measure could incorporate a notion of social or economic “distance” between groups (here regarded as constant), although the measure of distance is difficult to define in many cases (Duclos, Esteban, & Ray, 2004).

The third feature is that the fractionalization index is maximized when there are many very small groups. Consequently, two equally sized groups that split the population would be less heterogeneous than ten equally sized groups.

The index in principle does not account for assembly size and empirically is affected by “micronumerosity”, or “the problem of having few observations” (Goldberger, 1991). This limitation is somehow related to the theoretical concept of fractionalization, while the last limitation is empirical and may bring, in this case, two other empirical problems: heteroskedasticity and high correlations with assembly size. Both are problems related to the data; however, while the first problem is easy to

---

<sup>162</sup> The study by Montalvo and Reynal-Querol (2003) reports a clear example of the two indexes used to “measure the importance of religious interactions and potential conflict within a country” (p. 202):

“The index of religious fragmentation (FRAG) can be interpreted as the probability that two randomly selected individuals in a country will belong to different religious groups. The form of this indicator is the following:

$$FRAG_i = 1 - \sum_{j=1}^J (n_{ij} / N_i)^2,$$

where  $n_{ij} / N_i$  is the proportion of people affiliated to religion  $j$  in country  $i$ . Therefore,

FRAG increases when the number of groups increases. An alternative indicator of religious diversity is the index of religious polarization of Montalvo and Reynal-Querol (2000):

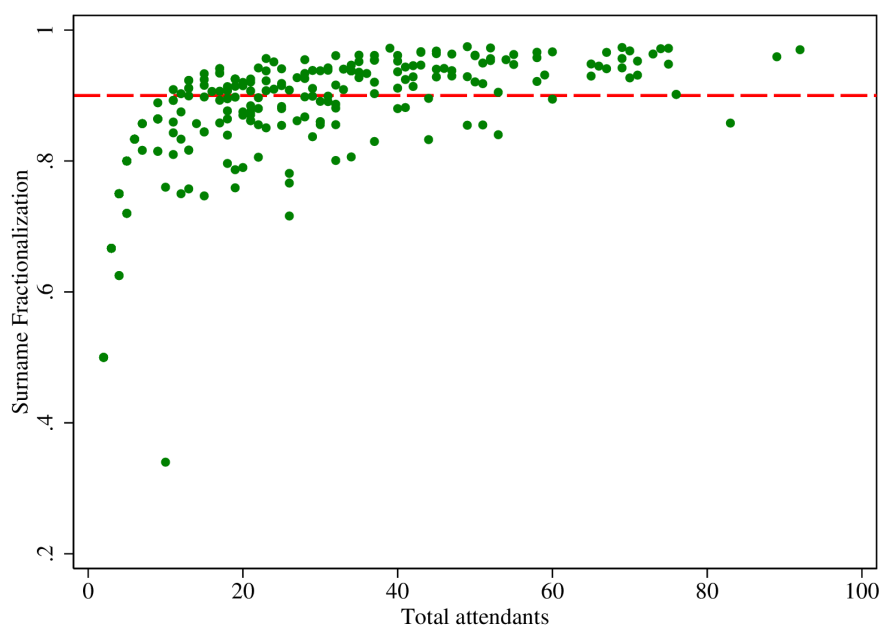
$$POL_i = 1 - \sum_{j=1}^J \left( \frac{0.5 + \pi_{ij}}{0.5} \right)^2 \pi_{ij},$$

where  $\pi_{ij}$  is equal to  $n_{ij} / N_i$ . The index  $POL$  ranges from 0 to 1. Contrary to what happens with the fragmentation index, polarization reaches a maximum when there are two religious groups of equal size. In this type of index, what matters is not only how many groups there are but also whether they view other groups as a potential threat for their interests. For a given number of groups, the threat is higher the larger the size of the other group relative to the size of the reference group. Therefore, the polarization index can reflect potential religious conflict in a society better than the fragmentation index.” (Montalvo & Reynal-Querol, 2003, p. 202)

account for, the second may indicate multicollinearity and requires further investigation.

The three problems, considered together, may raise the suspicion of endogeneity between assembly size and surname fractionalization when they are used together as independent variables in econometric models. Each of these limitations is discussed below.

The index provides a measure of social fragmentation regardless of assembly size: this might be problematic when the indicator used to measure fractionalization is the individual surname.<sup>163</sup>



*Figure 8.2.* Surname fractionalization index.

*Note:* N=252. To improve visualization, six assemblies with more than 100 attendants are omitted. The dashed line indicates a reference value of 0.9.

<sup>163</sup> For example, with three assemblies (a, b, and c) with only two families, A and B may have the same fractionalization index and yet have very different assembly size. Let the assemblies have size: a=10, b=100, and c=1000. Assembly a has 10 attendants in total, nine in family A, and one in B; assembly b has 100 attendants, 90 in A and 10 in B; assembly c has 1000 attendants, 900 in A and 100 in B. When calculating the fractionalization index, all the three assemblies turn out to have the same fractionalization index: The index represents as identical social situations that might be radically different.



As can be seen from Figure 8.2, many cases of assemblies of different size have a fractionalization index equal to 0.9 (mean=0.875, s.d.=0.095, N=258). In the same figure, it can also be noticed that there is a high index variability in the size of small assemblies: the distance between the minimum and the maximum surname fractionalization decreases as the size of the assembly increases—the data exhibit heteroskedasticity. This can be controlled in econometric analyses by computing robust standard errors and eventually running post-estimation testing for heterogeneity.

The correlation of the surname fractionalization index with group size may be due to mechanical factors related to the fractionalization index or have other explanations. To some extent, a positive correlation is intuitive, since surname fractionalization is computed on assembly attendance, while total attendance is the simple counting of the attendants. This problem may introduce statistical bias due to high cross-correlations of variables, which could be mitigated and yet not entirely solved.<sup>164</sup> Other studies on fractionalization, using this very index, report high cross-correlations, well above 0.6 (Alesina et al., 2003). A high collinearity will introduce noise in the estimates, and the issue will remain as long as post-estimation testing will detect (nearly) exact collinearity. To reduce this correlation, one solution might be a

---

<sup>164</sup> “Collinearity” occurs when two or more explanatory variables in an econometric model move together in systematic ways. A correlation of 0.51 or higher is not per se a problem and does not indicate collinearity. Exact collinearity is a serious problem, as it leads to the inoperability of ordinary least square regression; nearly exact leads to large standard errors. Other consequences are that  $R^2$  may be high, while individual coefficients are likely to be not significant; in addition, estimates will be sensitive to the addition of a few observations. Collinearity often depends on the presence of parameters restrictions and on the lack of data; however, accurate prediction may still be possible by relaxing parameters restrictions and finding additional data. The presence of large standard errors with high  $R^2$  and pairwise correlation coefficients in excess of 0.8 (which is not the case here) are just “rules of thumb,” granted that collinearity can be detected with appropriate statistical testing, like computing the variance inflation factor (VIF) test, in the post-estimation phase of econometric analysis. Studies in financial econometrics often report cross-correlations between interest rates that are above 0.9. Widely used undergraduate textbooks of econometrics often report similar examples: see, for instance, Section 6.4 “Poor Data, Collinearity, and Insignificance” in Carter Hill, Griffiths, and Lim (2011).

transformation of the index.<sup>165</sup> However, the disadvantage of this solution when applied to the present case would be a consistent loss of data.<sup>166</sup>

Table 8.2.

*Summary statistics*

Variable	Mean	Std. Dev.	Min.	Max.
Villages within a community	1.585	1.895	1	18
N		258		

A last solution would be computing another index of social heterogeneity and checking whether the correlation with assembly size is still high. In Table 8.2, the summary statistics are reported for another proxy for social heterogeneity: the number of villages represented in the assembly, which will be commented on in a separate subsection. In the dataset, the number of villages represented in the assembly ranges from 1–18, and the sum of the villages provides a measure of social fragmentation. The idea is that an assembly in which there are people from different villages pools individual preferences that are more heterogeneous than in assemblies with a single village. The correlation of the number of villages with assembly size is 0.45. The

<sup>165</sup> A common transformation is the “standardization” of the index so that its mean and standard deviation conform to a normal distribution. The desired result is obtained using a transformation of the index values:  $STD(x) = \frac{x - \mu}{\sigma}$ , with values distributed in conformity to a standard normal distribution  $N(0,1)$ .

<sup>166</sup> The “standardization” is mathematically impossible when the variance of the sample mean cannot be computed or equals zero. Similarly, a data transformation that would remove the mean/variance relationship is not desirable (meaning that the variability is different for data values with different expected values) so that the variance becomes constant relative to the mean (the effect would be the stabilization of the variance and is obtainable with, for example, a square root transformation): Although it may be biased, it is important information for a better understanding of the behavior of the surname fractionalization index with assembly size. Another solution that will eliminate the correlation of highly collinear variables would be the orthogonalization of one of the two variables: This result is fairly easy to obtain with many statistical software packages; however, it has the major disadvantage that the orthogonalized variables are complicated functions of the original variables and hence are of difficult interpretation.

correlation is lower than the 0.51 detected with surname fractionalization;<sup>167</sup> the comparison of the two correlations and the similar trend<sup>168</sup> appear to provide some support to the hypothesis that fragmentation represented by fractionalization and number of assembly roles are good proxies of “social complexity” and that they correlate with assembly size.

In conclusion, all the problems illustrated above have econometric remedies, even though the most desirable “...remedy lies essentially in the acquisition, if possible, of larger samples from the same population” (Goldberger, 1991). The next subsection sheds light on these limitations by further studying the properties of the surname fractionalization index using a Monte Carlo simulation.

**Monte Carlo simulation.** Monte Carlo methods are computational algorithms relying on the repeated generation of random numbers through random sampling. Monte Carlo experiments “mimic the theoretical properties of realization of random variables” and “can be used to verify that valid methods of statistical inference are being used” (Cameron & Trivedi, 2009, p. 119). In this case, the simulation will be useful to study the statistical properties of the surname fractionalization index.

A first purpose of the simulation is to better understand whether the simulated data replicates the same nonlinear relationship observed in historical data. The second information obtainable from this simulation is the observation of whether the nature of the correlation between assembly size and social fragmentation results from a bias introduced by the method of calculating surname fractionalization using the fractionalization index, or a consequence of third causes, thereby pointing to the social complexity explanation suspected after comparing the pairwise correlations of

---

<sup>167</sup> The cross-correlation between surname fractionalization and the number of villages within the assembly is almost 0.22.

<sup>168</sup> The scatter with the linear fit with assembly size in Figure 8.3, Appendix C, also confirms the same positive relationship and a similar nonlinear trend, although with a wider variation in the number of roles as the assembly size increases.

assembly roles versus assembly size. A third purpose is the observation of the behavior of max–min range (chosen as indicator of variability) of the simulated surname fractionalization with respect to assembly size and an estimate of how much this variation differs from the historical data.

A simulated index for assemblies having the same size  $N$  on a larger number of simulated observations, this time set at  $n=1000$ , is computed. The simulation follows a three-step procedure:

1. All individuals (a) having a surname (b) from every assembly (c) in every community (d) in every year ( $\sum N = 7,765$ ) are pooled together in a unique dataset.
2. “Random assemblies” are generated<sup>169</sup> by repeatedly drawing uniformly from the pool 1,000 random samples of assemblies (set of surnames) of different sizes  $N = \{1, 2, \dots, 295\}$ , every time with replacement. The reference to the famous Monte Carlo casino looks quite appropriate: the simulation works as if a gambler were drawing  $N$  balls from a spinning roulette wheel with  $j$  surnames for  $n$  trials in each round. The game is played for  $(\max N - \min N)$  rounds. In this simulation, there are 295 rounds (one per assembly size). The first round of the simulation has  $N = 1$  and entails  $n=1000$  trials; the second round has  $N = 2$  and another  $n=1000$  trials, and so on up to  $N = 295$  and  $n=1000$ . In plain words, this means that in every round of the simulation, a number of individuals/surnames equal

---

<sup>169</sup> The generator has been written in Java, and the code is available upon request. Thanks to Fabio Bruè, Department of Computer Science of the University of Bologna, for the inputs and the help in writing and “bugfixing” the code of the generator. The executable file requires setting few parameters: the number of random trials  $n$  for each community in each  $N$ . The routine draws repeatedly  $n$  samples of size from  $\min N$  up to  $\max N$  from the pool with replacement and is repeated from  $\min N$  up to  $\max N$ . The following parameters were used:  $n=1,000$ ,  $\min N = 1$  up to  $\max N = 295$ . To speed up computation, the routine has been broken down in 14 intervals and then appended together.

to the round number is randomly extracted from the pool and allocated in an assembly, and then replaced in the “urn” after each extraction.

3. An average surname fractionalization index is computed for every round.

Indexes for assemblies of each size  $N$  are defined with  $E(h_N)$ . The dataset of the simulation results after the collapsing of 295,000 observations and counts 295 average simulated surname fractionalization indexes for assemblies of every size, each calculated on 1,000 random trials of surname samples of the same size (simulated assemblies) obtained from the total pool of surnames.<sup>170</sup>

***Surname fractionalization: historical vs. simulated data.*** Figure 8.4

compares the results of the simulation with the historical data. In Panel (B), the line represents the simulated mean values. The figure summarizes analytically that social fragmentation measured by surname fractionalization is a nonlinearly increasing function of group size. Diamond and circle markers represent respectively the maximum and the minimum fractionalization obtained with the simulation. Panel (A) shows that the historical surname fractionalization indexes are included in an area delimited by an upper and a lower bound computed using the simulated data. The upper bound is defined as the maximum surname fractionalization  $l_s = \max h_s$  of the simulated assemblies. The lower bound is, instead, calculated as  $u_s = \max h_s - 25 \cdot (\max h_s - \min h_s)$ . The simulated max–min range is multiplied by an arbitrary constant  $k=25$  to preserve the information that it decreases as the assembly size increases.<sup>171</sup>

---

<sup>170</sup> Summary statistics of the simulated index are reported along with the historical index in Table 8.3, Appendix D.

<sup>171</sup> In order to enclose the range in a 0–1 interval, values below zero of the lower bound have been set to zero.

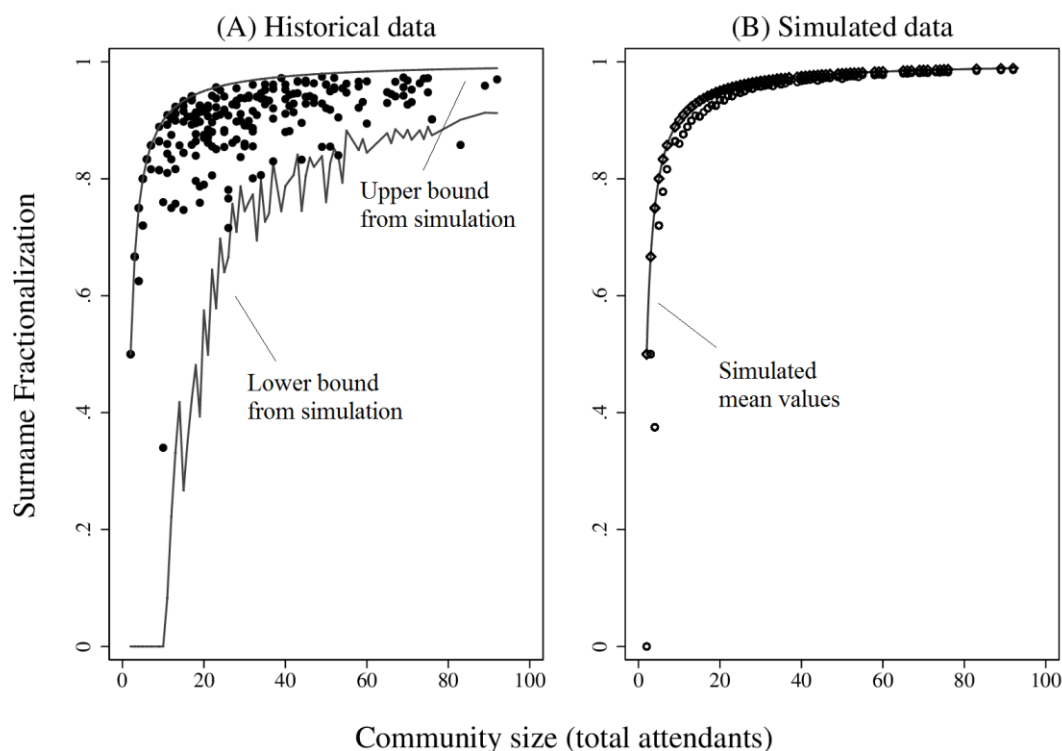


Figure 8.4. Surname fractionalization: historical vs. simulated data.

*Note.* Each dot of the historical data (Panel A) is a raw observations from one assembly in a given year ( $N=252$ ). Each data point in the simulation (Panel B) represents a mean computed on 1,000 random draws based on pooled historical data. 6 observations with total attendance  $> 100$  are omitted to improve visualization.

The cross-correlations of “historical” and “simulated” fractionalization index with assembly size are similar (0.514 and 0.515, respectively), which confirms that the correlation of assembly size with social fragmentation is linked with the methodology for computing fractionalization, and not specifically to this dataset. Surname fractionalization increases with group size and this property can be proven to be true in theory.<sup>172</sup>

**8.2.2. Resource heterogeneity.** One intuitive way to study resource heterogeneity is to use a fractionalization index that refers to classes of land resources.

<sup>172</sup> *Example.* Consider an assembly in which surname groups have only few representatives. The extreme case is that of 1 surname represented by 1 individual, but the following example holds also in case the surname  $j$  is represented by 10, 50, 100, or  $N_j$  individuals. By substituting  $\pi = N_j / N$  in Equation 8.1, algebraically, it is observed that  $h$  approximates the unit for large numbers of  $N$ .

An index of fractionalization applied to the study of the fragmentation in resource endowments has been used by Vedeld (2000); in general, the issues related to resource heterogeneity are considered quite problematic in the literature, both in conceptualization of the problem and, consequently, in the analysis of the impact of such heterogeneity (Adhikari & Lovett, 2006; Baland & Platteau, 1996; Nagendra, 2011; Naidu, 2005; Poteete & Ostrom, 2004; Varughese & Ostrom, 2001; Vedeld, 2000). The present subsection illustrates the application of a fractionalization index to measure resource fragmentation and describes the properties and the limitations of the measure. Properties and limitations of the index are discussed using a simulation.

Table 8.5.

*Resource fractionalization: summary statistics*

Variable	Mean	Std. Dev.	Min.	Max.
Resource Fractionalization	0.554	0.087	0.22	0.724
Total productive surface	1586.301	1596.631	68.7	10797.5
N		258		

**Measuring resource heterogeneity.** A resource fractionalization index is computed for each community in which the assembly takes place, regardless of resource type. The total productive surface of each community is divided into four categories: 1) vineyard, 2) other private land, 3) forest, and 4) pasture (meadows, grazing land, or alp). Each resource type is categorized in a group  $j$  ranging from 1 to 4: the index this time will interpret  $j$  as in one of the four “resource groups” instead of surname groups.

Let  $N$  be the total surface (number of hectares) in the community where the assembly takes place, and  $N_j$  the number of hectares belonging to the resource group  $j$

in the same community; then, the resource fractionalization index of the community is:

$$h = 1 - \sum_j \left( \frac{N_j}{N} \right)^2 \quad (8.3)$$

or, using probabilities:

$$h = \sum_j \pi_j (1 - \pi_j) \quad (8.4)$$

The interpretation of this index (of which summary statistics are reported in Table 8.5) is analogous to the one for surname fractionalization: an assembly is considered to be highly fragmented when the resource fractionalization in the community where the assembly takes place is close to one. High values of this index mean that one type of resource prevails over the others, because the probability of picking two hectares of the same resource type from the pool of the community's total hectares is low.

Decoding the meaning of the index requires positing that, when there is resource homogeneity, there is a lower level of transaction costs: assemblies specialize community governance in enforcing and monitoring property rights on few types of land and in smaller surface extensions. Conversely, the definition of property right on land entails higher levels of transaction costs when there are different types of resources to manage and/or in large extensions.

***Properties and limitations of the resource fractionalization index.*** In principle, it is not expected that resource fractionalization would raise statistical issues similar to surname fractionalization, as it displays a low correlation with the total surface (-0.21, significant at the 5% level). As done for the surname fractionalization index, the present subsection outlines three properties of the resource fractionalization index.



The first feature descends from a limitation in the data. The values in each category of land resources were estimated from the 1897 Land Register. It is assumed that community boundaries had not changed over time. The 1897 Land Register is organized in cadastral units, and an estimate of the historical surface of each community was obtained by adding or subtracting the 1897 cadastral units referred to the villages that were part of the historical community.<sup>173</sup>

The second feature is “mechanical”: the index is calculated on custom resource categories based on the categorization retrieved in the 1897 Land Register. From the original data, unproductive land is excluded, and productive land is divided into four categories that allow for different levels of transaction costs. This categorization does not fully capture the resource dynamics of each category (stock, flow and growth rate): nevertheless, it allows for different production between forest and pasture areas, and, similarly, between vineyards and other private property (arable land and fruit garden). An alternative way to build the fractionalization index is to weight resources by their production value, which a different categorization with additional data could have achieved.

Generally, forest and pasture (commons) are predominant in large communities, while vineyard, arable land, and fruit garden are predominant in small communities.<sup>174</sup> As a consequence, in large communities, the index will be heavily influenced by the forest and pasture portfolio. The mean of the index is expected to be

---

<sup>173</sup> The historical surface of the community was reconstructed following the description of the community boundaries retrieved in the preamble of the charters and other historical sources. When a historical surface changed over time for the same community, the observations are counted as separate and with no relation to the original community. The empirical consequence of this limitation is that each of the 156 communities that are represented in the dataset may also occur more than once if more assemblies have places in it; however, the max–min range of resource fractionalization will always be the same in each level of surface extension, because resource fractionalization does not change in assemblies held in the same community.

<sup>174</sup> Figure 8.7, Panel A, Appendix C, displays the relative importance (measured in percentage on the total surface) of each of the four resource categories, plotted versus the total land surface. Vineyard, arable land, and fruit garden were summarized in Figure 8.7, Panel B, Appendix C, under “non-commons.”

stabilized at  $h=0.5$ , while the max–min range is expected to decrease with the increase of the total surface.

A third feature of the index is that resource fractionalization does not account for land extension. For example, three communities—a, b, and c of 100, 1,000, and 10,000 hectares each, respectively—can have  $h=0.5$  and two types of resources (A and B). In this case, a control for surface extension would distinguish high values of resource heterogeneity in communities having a small or large extension.

**Monte Carlo simulation.** Another simulation was performed to investigate the properties of the index in communities where the land composition is built through the random extraction. The previous section raised three important issues concerning the resource fractionalization index—the problem of small sample size, the internal impact of categories on the computation of resource fractionalization, and the problem of filtering out the effect of surface extension in this index.

The goal of the simulation this time is to obtain simulated indexes for  $n=1,000$  random communities having the same total surface  $N$ . The Monte Carlo generator this time draws a ball in a spinning roulette wheel having only four alternatives for each of the hectares compounding the surface (up to 10,798) and does this 1,000 times for each of the communities (up to 156 “rounds”). In the first round, the generator draws  $N = 69$  random hectares (the minimum total surface in the dataset) of different types for  $n=1,000$  times. In the last round, the generator is programmed to draw  $N = 10,798$  random hectares (the maximum) of different types for  $n=1,000$  times.

The routine adopted was the following:

1. A dataset was created that pools all the hectares of productive land for every assembly and for every year, divided in four categories. Each observation is a hectare and has a value ranging from 1–4 depending on

the category the hectare belongs to. For example, a community of 300 hectares with 120 hectares of forest has 300 observations, and 120 of these observations are coded as “forest.” The total surface of all the communities in every assembly and every year is  $\sum N = 239,936$ .

2. The generator draws uniformly from the pool  $n=1,000$  random samples of communities (set of resource types) of different sizes  $N = \{69, \dots, 10798\}$ , every time with replacement. The generator should have created  $n=1,000$  samples of  $N$  size for  $(\max N - \min N) = (10,798 - 69) = 10,729$  times.<sup>175</sup>
3. The dataset produced by the simulation allowed the calculation of resource fractionalization in each of the random surfaces generated for 1,000 times, building a dataset with 151,000 resource fractionalization indexes. From this dataset, it was possible to compute the average resource fractionalization index on  $n=1,000$  observations for each round of the total surface extensions. The final dataset of the simulation resulting after the collapsing of the intermediate dataset counts 151 average simulated resource fractionalization indexes.

---

<sup>175</sup> Due to limited computing power, the  $n=1,000$  samples were created only for the 156 communities of different total surface that required the simulation. Since in the original data, the total surface sometimes is not an integer, before pooling the data, the surface of each community was rounded to the nearest integer so that the number of rounds decreases from 156 to 151.

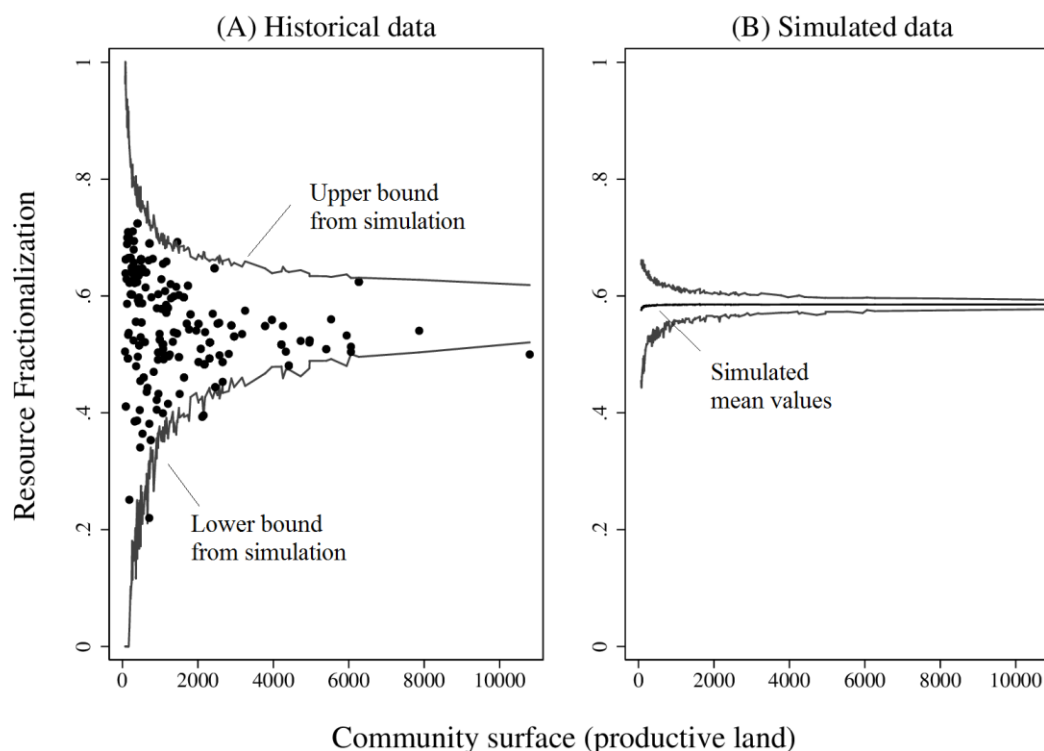


Figure 8.8. Resource fractionalization: historical vs. simulated data.

*Note.* Each dot of the historical data (Panel A) is a raw observations from one community in a given year ( $N=258$ ). Each data point in the simulation (Panel B) represents a mean computed on 1,000 random draws based on pooled historical data.

**Resource fractionalization: historical vs. simulated data.** The results of the simulation are plotted in Figure 8.8. Panel (B) reports the mean resource fractionalization obtained from the simulation.<sup>176</sup> Interestingly, the mean resource fractionalization maintains a flat trend as the total surface increases. In addition, the cross-correlations between the fractionalization index and the total surface are very different in the simulated and historical data,<sup>177</sup> which suggests the absence of endogeneity between resource fractionalization and total surface. The minimum (lower line) and the maximum (upper line) resource fractionalization of the 1,000 trials for each of the rounds are also shown: the max–min range is visually detectible

<sup>176</sup> Summary statistics are reported in Table 8.6.

<sup>177</sup> Table 8.7, Appendix D.

as the total surface increases. The minimum resource fractionalization increases, while the maximum decreases, with a trend around the mean simulated resource fractionalization.

Panel (A) in Figure 8.8 demonstrates that the historical resource fractionalization indexes can be enclosed in the area between an upper and a lower bound obtained from the maximum and the minimum of the simulated

fractionalization indexes. The upper bound is computed as

$u = \max h + 1.555 \cdot (\max h - \min h)$  and the lower bound as

$l = \max h - 4.5 \cdot (\max h - \min h)$ . The constants  $k=1.555$  and  $k=4.5$  are chosen

arbitrarily, so that the minimum observations are left outside the area of inclusion, to preserve the information that the max–min range decreases as total surface increases.<sup>178</sup>

In conclusion, resource heterogeneity may be considered as independent from total surface and the number of attendants to assemblies. The practical consequence is that two communities of 100 hectares and 1,000 hectares can have the same  $h = 0.5$  without need of corrections. The insertion of an interaction term could separate, in econometric analyses, the partial effect of total surface in the resource fractionalization index; however, this would be more harmful than beneficial for estimates, because it is likely to introduce problems of collinearity.

**8.2.3. Institutional design.** The purpose of this subsection is to define the specifications and the measurements of institutional design employed in the chapter (institutional features). A database of 258 assemblies offered the possibility of building a number of proxies for institutional design. Five indicators are drawn from the text of the *Carte Di Regola* about: (i–ii) and institutional complexity, (iii) the

---

<sup>178</sup> In order to enclose the range in a 0–1 interval, estimates of the upper bound above 1 are set to 1, while lower-bound estimates below zero are set to zero.

balance between governance rules and resource management rules, (iv) institutional stability, and (v) consensus. A separate subsection is dedicated to each class of indicators, and conjectures are formulated that will be tested using multiple regression analysis. The conjectures concern how variations in each institutional feature may be affected by the sources of social and resource heterogeneity described in the previous sections.

***Complexity.*** Two indexes of complexity are constructed: the length of the document decided by the assembly and the number of assembly roles.

*Length of the document.* The length of the document consists of the count of the number of articles contained in a *Carta di Regola* or other document. The length is related to the choice of the assembly to write a “complete” social contract or to leave some gaps. Among the 258 assemblies reported in the data, there are 243 documents for which it is possible to count the number of the articles, each corresponding to a specific rule.<sup>179</sup>

The decision of leaving long-term contracts incomplete can be strategic (Bernheim & Whinston, 1998) and is a risk that the assembly undertakes, as it may be reflected in the quality of law enforcement, internal conflict, and litigation with bordering communities.<sup>180</sup> Historical documents of the Princedom of Trento (the Trentino region) report that the costs of border litigations between villages were severe, and that litigations persisted for decades. It is plausible that communities with longer charters were those communities more complex to manage in terms of rule

---

<sup>179</sup> Although in principle, the length of the document could be decided by the single notary writing the document, a careful read of the preambles of the documents reveals that the number of provisions and the content of the rules are decided by the assembly. From the econometric point of view, idiosyncrasies in document drafting represent part of the unexplained variance.

<sup>180</sup> The issue of contract incompleteness has been widely explored and benefits from well-established reference literature. The main references for an economic treatment of the topic are the seminal contributions by Hart and Moore (1988) and Tirole (1999). From a law & economics perspective, a key reference is Ayres and Gertner (1989).

enforcement and the monitoring of resource use. Therefore, long documents can proxy the ex-ante investment in better-quality contractual enforcement and might be a precise legislative choice when the internal organization is structured on two or more levels. In such a case, the higher organizational level might opt for the adoption of a framework charter, whereas single villages might have a detailed charter. There are three additional considerations on the choice of a short charter:

1. Short documents are preferable when they serve as framework charters; that is, documents providing the grounding principles of community governance. Short and framework-oriented charters might last longer as, due to their generality, they do not require frequent renegotiation or replacement. These charters are likely to be less complex, though incomplete (Negretto, 2012).
2. Short documents may also be less durable, particularly when they are “gap filling” documents, as amendments or replacements of old rules (Negretto, 2012).<sup>181</sup> A similar conclusion is reported by Hammons (1999) in conclusion of an empirical analysis of American constitutions.<sup>182</sup> The possibility of introducing modifications is a form of “constrained revision” that, as Chung (1991) argues, is aimed at correcting the inefficiencies deriving from contractual incompleteness when new information becomes available to consociates. This choice might also be strategic, as Crocker and Reynolds (1993) later found in the empirical study of pricing

---

<sup>181</sup> When the result of collective contracting in assembly is a modification of the charter, the complexity measured is that of the modification.

<sup>182</sup> In this study, Hammons (1999) criticized what he called the “Madisonian hypothesis,” which posits the following: “The shorter the total length of the constitution and the smaller the number of statutory-type provisions as a percentage of the total document, the more durable the constitution will be” (p. 838). The results of his study on American constitutions reject this hypothesis (p. 845).

procedures used in Air Force engine procurement contracts. Thus, even incomplete contracts can be efficient.

3. In addition, shorter documents entail less accountability of the governing village members to non-governing ones. This “decentralization” process is generally preferred over the risk of competition of the jurisdictions between the main-village and sub-village, consisting of the allocation of governing power at the local level under incomplete contracting. This choice entails higher risks of accountability for the governing board, and the problem is solved with a detailed piece of legislation for the local level: the local differentiation of the public good (charter) allows higher benefits,<sup>183</sup> because it “induces individuals to reveal the true preferences for levels and combinations of the public good provided by means of their location decision” (Seabright, 1996). In the case of rural charters, the first problem is overcome with a periodical (usually yearly) role-rotation system in community appointments. The number of articles dealing with community governance can be a suitable measure of institutional content.

In conclusion, if heterogeneity increases transaction costs, the gap filling process through collective bargaining requires more details to be specified in the resulting institutional design. Less heterogeneous societies are likely to require less complex institutions and, therefore, shorter documents.

*Number of roles in the assembly.* Each individual in the assembly is associated with an assembly role that specifies the member’s function in the assembly: village member, mayor, officer, etc. The 258 assemblies had a number of roles that ranged

---

<sup>183</sup> Seabright (1996) argues, “[C]entralisation allows benefits from policy coordination but has costs in terms of diminished accountability, which can be precisely defined as the reduced probability that the welfare of a given region can determine the re-election of the government.”



from 1–7.<sup>184</sup> The number of roles was not fixed, and the type remained basically unaltered throughout the six centuries. The number of roles in the assembly may be a useful indicator of the degree of government specialization required to govern the community.

When population increases, the community government can specialize in monitoring and enforcement in order to benefit from the higher returns on scale in such activities, which would otherwise be excessively expensive. Typical examples include the election of full-time monitoring officers or full-time shepherds to graze the community herd. If surname heterogeneity has an impact on institutional features, governments that are larger in terms of assembly attendance and resource endowments should be more heterogeneous and might require a higher degree of board specialization (Doupé, 2011) and hence more assembly roles.

This consideration seems to find support in the dataset: communities in which rule enforcement and resource monitoring were easier probably required a simpler governance organization.

In conclusion, institutional complexity can be represented by charter length and the number of roles represented in the assembly.

Whether and how these features vary with social and resource fragmentation is the next step of the argument. In light of the preceding reasoning, three conjectures are formulated:

C1-1 Higher surname fractionalization generates more complexity;

C1-2 A higher number of villages within a community generates more complexity;

C1-3 Higher resource fractionalization generates more complexity.

---

<sup>184</sup> In Chapter 3, a summary table with all the roles in the assembly dataset is provided.

***Governance vs. resource management.*** Articles containing community governance rules and resource management rules were counted in each document.<sup>185</sup> The absolute frequency of community governance rules and of resource management rules can be considered as indicators of the transaction costs in two distinct aspects of institutional collective action. An interesting measure is the ratio between the number of community governance rules to the total number of articles, as it indicates the importance perceived by the assembly of the costs required for governing the institution relative to the costs of disciplining the technical aspects of resource extraction. When the purpose of an institution is to solve a collective action problem concerning resources, one would expect a high frequency of articles to contain rules on resource management. Accordingly, as a proportion of the total, resource management are expected to represent the vast majority of rules. When the insider group is fractionalized, one would expect a high frequency of articles dealing with the structure and governance of the institution to coordinate the members' resource extraction in order to avert the tragedy of the commons (Hardin, 1968; Ostrom, 1990).

Three conjectures may be stated as follows:

C2-1 Surname fractionalization impacts on the frequency of community governance rules;

C2-2 The number of villages within a community impacts on the frequency of community governance rules;

C2-3 Resource fractionalization impacts on the frequency of resource management rules.

***Stability.*** The number of years between the assembly and the next institutional change requiring an assembly can be used as a proxy of the durability of institutional

---

<sup>185</sup> The structure of the regulation and the coding process adopted to construct the relevant variables and formulate three conjectures are described in detail in Chapter 3.

rules. An explanation is connected to the theory of voting. Voters with heterogeneous preferences might form unstable coalitions (Arrow, 1950; Aumann & Dreze, 1963): this instability might have origins in external shocks, such as changes in relative prices, having asymmetric effects (i.e., having a different impact on a peasant than a craftsman, etc.). Consequently, heterogeneous governments are likely to be politically unstable and require higher government consumption to mitigate social conflicts (Annett, 2001).

From the reconstruction of the time sequence of the documents, a measure of institutional stability of the documents was computed. It was only possible to compute the distance from the next change for 62 village assemblies.<sup>186</sup> The documents analyzed in this chapter (N=258) are divided into complete *Carte* (including replacements) or amendments and other documents.<sup>187</sup> A cursory view of the endurance of the institutional changes documented in the dataset shows figures that deserve attention: the average duration of 43 complete charters until the next change was approximately 121 years and ranged from 1–376 years, while the average duration of 19 amendments and other related documents until the next change was 184 years and ranged from 88–301 years. It is possible to expand the sample to include more observations by setting the year of next change to 1807, when Napoleon abolished the charter regime. As will be later explained, these estimates do not capture the total duration of changes and are affected by right censoring.<sup>188</sup> The econometric model should also account for different types of change: complete replacement or modification (Negretto, 2012). Intuitively, changing something that

---

<sup>186</sup> Table 8.14.

<sup>187</sup> Summary statistics are provided in Table S.5 and Table S.6, both in Appendix D.

<sup>188</sup> If institutional change and the abolition of the *Carte* regime that occurred in 1807 is considered as relevant, the average duration of the 165 complete charters under analysis is approximately 203 years and ranges from 1–533 years, while the average duration of the 74 amendments and other related documents is 157 years and ranges from 6–558 years.

already exists entails lower transaction costs than writing and reaching an agreement on an entirely new institution.

This reasoning leads to the following conjectures:

C3-1 Surname fractionalization lowers stability;

C3-2 Resource fractionalization lowers stability;

C3-3 The number of villages within a community lowers stability.

*Consensus.* Quorums measure the percentage of attendants who cast a vote in the assembly and represent the level of consensus required to approve the institution.<sup>189</sup> The quorum can be interpreted as a measure of the level of preference aggregation required to reach a collective decision. The process of preference aggregation is typically simpler in smaller groups, because the chances are that individual preferences are less heterogeneous than in larger groups, on a purely statistical basis. Social fragmentation, making the aggregation of social preferences more difficult (Arrow, 1950; Brown, 1975), increases the costs of social contracting for the allocation of property rights. Therefore, one might expect that more socially fragmented groups tend to decide with lower quorums and deliberate unstable (in our language, “less enduring”) rules.<sup>190</sup>

The documented quorum, in the present study, is always above the simple majority (50 percent plus one vote) and very close to a super-majority (75 percent);<sup>191</sup> however, this figure does not account for the difference in quorums with other factors, such as the number of attendants or social heterogeneity. Highly fractionalized groups

---

<sup>189</sup> For a discussion concerning the meaning and interpretation of assembly quorums, the reader is addressed to Section 3.2.4, under “Participation”.

<sup>190</sup> Majority and supermajority quorums are usually placed to avoid cycles in voting that would lead to decisional deadlock, as stated by Arrow (1950) in the formulation of the “impossibility theorem,” later developed in many studies on collective decision-making and preferences aggregation including Brown (1975).

<sup>191</sup> Table 8.8, Appendix D.

might take longer to reach a decision that is approved by a smaller subgroup with a lower quorum, which may later be overturned. The following conjectures are stated:

C4-1 Surname fractionalization lowers quorum;

C4-2 Number of villages within a community lowers quorum;

C4-3 Resource fractionalization lowers quorum.

**8.2.4. Econometric model.** Several methods have been used in the past to estimate the impact of social and resource heterogeneity on various economic outcomes; an overview of these methods can be found in Banerjee et al. (2008). The present subsection describes the methodology adopted to perform statistical analyses. A description of results and post-estimation testing follows in a separate section.

The empirical strategy adopted to analyze the evidence and provide statistical testing to the conjectures stated previously makes use of multiple regression analysis. In general, Ordinary Least Square (OLS) regression specifications with pooled data on assemblies are used for each of the institutional features, while heterogeneity—consistently with the research framework outlined at the beginning of this section—is considered among the independent variables together with other controls.

The proceeding subsections first list the dependent variables and the independent variables; illustrate how endogeneity, heteroskedasticity, collinearity, and other problems related to fractionalization are solved in the empirical model; and then state the final estimating equation and the goals of each model specification.

***Dependent variables.*** One peculiarity of this study is that the dependent variables are not economic outcomes but features that represent the “institutional design” as identified above.

The length of a *Carta* (*LENGTH*) is measured as the count of the number of articles that are contracted out in each assembly, and they represent one index of

complexity of the institution that results from the collective face-to-face agreement, regardless of the type of the document: a control for whether the document is a full charter or an amendment is present with the insertion of a dummy variable among the independent variables; subsequent replacements by full charters are treated as first full charters, as they are institutional changes that are conceptually identical from the point of view of collective action.

The number of roles in the assembly (*ROLES*) is, instead, the simple count of the different roles vested by the attendants during each assembly, regardless of the type of the role and its relative frequency on the total of the attendants.

In order to measure the importance of governance rules versus resource management rules, three different sets of regressions are run. The first two sets hold as dependent variables the absolute frequency of community governance rules (*GOVREG*) and of resource management rules (*RESREG*), as identified in the previous section. The last regression set holds as a dependent variable the ratio of community governance rules to the total of contracted articles (*FGOVREG*); being the remaining rules devoted to resource management, this variable measures the relative importance of managing the group in the institutions versus the total of the rules. When this variable increases and approaches the unit, the relative importance of resource management proportionally decreases toward zero.

Another set of regressions was run to investigate the determinants of the stability of institutions (*STABIL*), measured as the number of years before the next institutional change when there are multiple observations of assemblies for the same community over the years. The *Carte* system was forcefully abolished in 1807, and it is assumed that once a community adopts a *Carta*, it is locked in the institution until the abolition of the system. Therefore, when estimating the forward duration of a

document, the strategy may be twofold: it is possible to concentrate only on institutional changes reported in the documents, or consider also 1807, the year of the abolition of the system, as the year of last institutional change. The first alternative provides estimates based on changes that are provoked internally and results in a smaller sample; the second includes all institutional changes, produces estimates based on a larger sample, but inserts two problems: it does not distinguish endogenous from exogenous institutional changes, and it produces estimates that are biased by right censoring (as there could be institutions that, in absence of the exogenous event, would remain in force after the year 1807 with no need of being replaced or amended). On the basis of these complications, the first alternative is preferred over the second, although the second alternative could have been tackled econometrically using a censored-normal regression model, which fits models with a dependent variable containing both censored and non-censored observations on the process.

The last set of regressions has deliberative quorum (*QUORUM*) as a dependent variable and is expressed in fractional form (0.5, 0.75, ... , 1). An OLS estimation model is used for the sake of consistency and to improve the ease of interpretation of the results, given that frequencies are not excessively compressed toward the extremes.<sup>192</sup>

***Independent variables.*** Among the independent variables inserted were measures for social heterogeneity and resource heterogeneity, assembly size and surface extension, and other controls.

---

<sup>192</sup> Having a dependent variable that has fractional values may lead to imprecise estimates when there are high frequencies toward the extremes (0 and 1), and in these cases, the use of models that work on a logit transformation of the dependent variable looks more appropriate (Papke & Wooldridge, 1996).

Social heterogeneity is represented by adjusted surname fractionalization, a logarithmic transformation of the surname fractionalization index (*SURN*),<sup>193</sup> and by the number of villages within a community (*VILL*). Resource heterogeneity is instead represented by resource fractionalization (*RES*). The number of attendants in each assembly (*SIZE*), the total productive surface extension in hectares, was included. Documents were divided in two sets: complete charters and amendments to complete charters; a dummy variable accounts for the type of the document (“Charter amendment,” a dummy that equals 1 if the document is a modification of a previous charter and 0 otherwise), as suggested by Negretto (2012). Also included was the linear distance in kilometers from the closest urban center of the valley (“Closest local town”) and a dummy that controls for endowment of commons above the sample median (“Large commons endowment”). A set of 14 dummies controlled for “Area fixed effects,” while the year of the assembly controlled for “Time trend.” One interaction term,  $SURN \times SIZE$ , controls for the partial effect of the number of attendants on adjusted surname fractionalization.

**Estimating equation.** To estimate the impact of the determinants of public good provision, the following estimating model is commonly used in the literature:

$$y_{ikt} = f(p_{it}, x_{it}) \quad (8.5)$$

---

<sup>193</sup> The raw index has a distribution remarkably asymmetric towards high values of surname heterogeneity (Figure 8.2, Appendix C; summary statistics in Table 8.1, Appendix D). In many cases, applying a monotone transformation is helpful to give a variable a more symmetric distribution to construct 95% confidence intervals and to improve visualization. As to the first aspect, it is known that 95% confidence intervals are computed by taking the sample mean plus or minus two standard error units. The constant factor of 2 for the standard errors is proper to the normal distribution and varies if the sample mean varies normally; however, if the distribution is skewed and the sample size is small, the estimated interval might have poor probability coverage. Figure 8.6, Panel A, Appendix C, represents the kernel density plot of (a), the original surname fractionalization, while (b) plots the kernel density of a logarithmic transformation of the same index using  $h' = -\ln \cdot (1 - h)$ . As to data visualization, Figure 8.6, Panel B, Appendix C, shows how, with this monotone transformation, the result of “stretching” the original fractionalization index was obtained over a wider interval.



where  $y_{it}$  is a measure of access or quality of public good  $k$  (in this case, the *Carta*) in assembly  $i$  at time  $t$  and  $p_{it}$  is a set of characteristics of the population (in this case, of the community in which the assembly takes place) in assembly  $i$  at time  $t$ . This last function may include measures of heterogeneity, while  $x_{it}$  is a vector representing various geographical and historical features of the area in which the community is located (Banerjee et al., 2008).

An interesting improvement of this model related to institutional design and change is inspired by a recent unpublished paper by Crowley (2011):

$$y_{i(t+1)} = \beta_0 + \beta_1 p_{it} + \beta_2 x_{it} + \varepsilon \quad (8.6)$$

with  $\varepsilon \sim N(0,1)$ . In this specification, only one type of public good (the *Carta*) is assumed and the dependent variable is meant to represent some “constitutional characteristics” in the post-decision period, while  $p_{it}$  captures heterogeneity specifically in the pre-decision period and vector  $x_{it}$  represents additional characteristics always in the pre-decision period. The equation model (8.6) is explicitly targeted to capture the effect of pre-existing fragmentation on institutional design: it uses post-decision variables in the left-hand side and pre-decision explanatory variables on the right-hand side, thereby discounting the potential endogeneity between the dependent and the independent variables.

A more complete specification can be written as:

$$y_{i(t+1)} = \beta_0 + \beta_1 SURN_{it} + \beta_2 RES_{it} + \beta_3 OTHER_{it} + \varepsilon_{it} \quad (8.7)$$

This time, the equation separates the effects of social heterogeneity (*SURN*) and resource heterogeneity (*RES*) in each assembly. In order to filter out the partial effect of assembly size (*SIZE*) on surname fractionalization, the model needs to be completed as follows:

$$y_{i(t+1)} = \beta_0 + \beta_k SURN_{it} + \gamma_m RES_{it} + \delta_n OTHER_{it} + \varepsilon_{it} \quad (8.8)$$

where  $\beta_k = \beta_0 + \beta_1 SIZE$ . The final estimating equation includes one interaction term in the regressions. However, this choice controls for the presence of significant partial effects. It also has some “costs”: interaction terms normally exacerbate high cross-correlations and worsen collinearity between the fractionalization index, interaction term, and assembly size.<sup>194</sup>

The coefficients of independent variables will represent how many units the dependent variable will vary with a unit increase in the independent variable, holding all other variables fixed. The interpretation of coefficients of interaction terms requires some clarification (Wooldridge, 2003, p. 197). Let us consider the effects of surname fractionalization: the coefficient  $\beta_0$  on *SURN* indicates the partial effect on the dependent variable of a unit increase of adjusted surname fractionalization when no one is attending to the assembly (assembly size is zero), while the coefficient  $\delta_0$  on *SIZE* indicates the partial effect of a unit increase in assembly size on the dependent variable when there is perfect homogeneity (surname fractionalization is zero). The coefficient  $\beta_1$  on *SURN* × *SIZE* indicates how the effect of surname fractionalization on the dependent variable changes with the addition of one member to the assembly.

### 8.3. Results and Discussion

In total, five sets of OLS regressions were run separately to analyze the impact heterogeneity and size on each institutional feature: charter length (Table 8.9), number of roles in the assembly (Table 8.10), governance rules versus resource

---

<sup>194</sup> Another possible econometric alternative that has been considered, particularly for surname fractionalization, is to “discretize” the fractionalization index: The index could be substituted by a set of dummy variables representing homogeneous classes of the index (like deciles). As a result, instead of one variable representing surname fractionalization, there would be many dummies representing the deciles, which can also be interacted with assembly size. The advantage of this choice would be the reduction of the correlation of the index with assembly size. However, major disadvantages would be the loss of significance due to the large number of variables and the reduction in precision of the dummies that would represent large percentiles.

management rules (Table 8.12), stability of institutions (Table 8.14), and assembly quorums (Table 8.15). Each of the sets contains a “benchmark” model that accounts for time trend and area-sized effects and another model that does not. The other two models are specifications of the benchmark in which adjusted surname fractionalization (*SURN*) or the total attendance (*SIZE*), respectively, have been removed to understand the importance and the relation of the two factors. For ease of immediate comparison of which of the independent variables has a greater effect on the dependent, standardized coefficients are sometimes reported in a separate table.<sup>195</sup>

The remainder of the present section shows the regression tables and discusses the results. Separate subsections are dedicated to effects of social and resource heterogeneity (the “heterogeneity” box in Figure 8.1) and to effects of assembly size and surface extension (the “size” box in Figure 8.1).

---

<sup>195</sup> Standardized coefficients ignore the scale of units of the independent variables, which after the standardization all have variance equal to 1. Therefore, standardized coefficients refer to how many standard deviations the dependent variable will change in response to a one-standard deviation increase in the independent variable.

Table 8.9.

*Complexity of institutions: document length*

	(1)	(2)	(3)	(4)
Adjusted Surname Fractionalization	6.241* (3.284)	7.201** (3.279)		8.849*** (3.082)
Adj. Surname Fract. × Assembly Size	-0.148** (0.058)	-0.0941* (0.053)		0.0158 (0.019)
Resource Fractionalization	24.61 (19.856)	8.437 (24.379)	6.996 (24.185)	8.515 (24.728)
Villages within a community	-2.596** (1.112)	-2.869*** (1.033)	-3.396*** (1.060)	-3.346*** (1.031)
Total attendants	0.767*** (0.244)	0.481* (0.245)	0.232*** (0.074)	
Total productive surface	0.00166 (0.002)	0.00165 (0.001)	0.00140 (0.001)	0.00170 (0.001)
Charter amendment	-37.12*** (3.666)	-38.38*** (3.751)	-39.65*** (3.827)	-39.26*** (3.798)
Large commons endowment	-2.535 (4.619)	-0.126 (4.508)	1.302 (4.637)	-0.452 (4.486)
Distance from closest local town	0.0739 (0.422)	0.0732 (0.404)	0.0362 (0.399)	0.158 (0.419)
Constant	13.17 (13.729)	17.10 (46.496)	22.83 (45.863)	-6.588 (45.286)
Observations	243	243	243	243
$R^2$	0.39	0.45	0.43	0.44
Number of Communities	151	151	151	151
Time Trend	NO	YES	YES	YES
Area Fixed Effects	NO	YES	YES	YES

OLS, robust clustered standard errors in parentheses clustered per community.

Dependent: number of articles in the document.

\*  $p < 0.10$ , \*\*  $p < 0.05$ , \*\*\*  $p < 0.01$

Table 8.10.

*Complexity of institutions: number of assembly roles*

	(1)	(2)	(3)	(4)
Adjusted Surname Fractionalization	0.364** (0.168)	0.647*** (0.148)		0.765*** (0.128)
Adj. Surname Fract. × Assembly Size	-0.0153*** (0.004)	-0.00670 (0.004)		0.00126 (0.001)
Resource Fractionalization	1.848* (1.112)	1.529 (1.295)	1.333 (1.338)	1.509 (1.319)
Villages within a community	0.0771 (0.066)	0.0419 (0.062)	0.00911 (0.054)	0.00838 (0.056)
Total attendants	0.0756*** (0.014)	0.0347** (0.017)	0.0196*** (0.004)	
Total productive surface	-0.0000705 (0.000)	0.0000172 (0.000)	-0.00000520 (0.000)	0.0000172 (0.000)
Charter amendment	0.209 (0.191)	-0.0289 (0.171)	-0.110 (0.170)	-0.0964 (0.174)
Large commons endowment	-0.123 (0.264)	-0.0129 (0.260)	0.0946 (0.267)	-0.0391 (0.261)
Distance from closest local town	-0.0417*** (0.014)	-0.0120 (0.017)	-0.0135 (0.018)	-0.00468 (0.017)
Constant	0.875 (0.742)	-6.668*** (1.506)	-5.822*** (1.463)	-8.282*** (1.474)
Observations	258	258	258	258
$R^2$	0.32	0.48	0.43	0.47
Number of Communities	156	156	156	156
Time Trend	NO	YES	YES	YES
Area Fixed Effects	NO	YES	YES	YES

OLS, robust standard errors in parentheses clustered per community.

Dependent: number of roles in the assembly.

\*  $p < 0.10$ , \*\*  $p < 0.05$ , \*\*\*  $p < 0.01$

Table 8.12.

*Content of regulation*

	(1)	(2)	(3)	(4)	(5)	(6)	(7)
Adjusted Surname Fractionalization	2.869** (1.210)		3.653*** (1.116)	4.678* (2.616)		5.756** (2.409)	0.0878*** (0.032)
Adj. Surname Fract. × Assembly Size	-0.0551** (0.025)		-0.000262 (0.005)	-0.0611 (0.057)		0.0143 (0.015)	0.000261 (0.001)
Resource Fractionalization	-8.022 (8.348)	-9.008 (8.037)	-7.759 (8.229)	16.63 (21.519)	15.64 (21.483)	16.98 (21.833)	-0.181 (0.233)
Villages within a community	-0.613 (0.501)	-0.891* (0.510)	-0.841* (0.499)	-2.140** (0.860)	-2.468*** (0.843)	-2.457*** (0.842)	0.000845 (0.009)
Total attendants	0.242** (0.115)	0.0714*** (0.024)		0.333 (0.261)	0.167** (0.065)		-0.00243 (0.003)
Total productive surface	-0.000355 (0.001)	-0.000482 (0.001)	-0.000323 (0.001)	0.00201* (0.001)	0.00183* (0.001)	0.00206* (0.001)	-0.00000857 (0.000)
Charter amendment	-12.50*** (1.490)	-12.94*** (1.522)	-12.86*** (1.502)	-23.57*** (2.773)	-24.30*** (2.806)	-24.11*** (2.823)	-0.0144 (0.042)
Large commons endowment	-0.230 (1.946)	0.343 (2.045)	-0.330 (1.983)	-1.165 (3.258)	-0.0982 (3.282)	-1.306 (3.218)	-0.0530 (0.042)
Distance from closest local town	-0.0288 (0.121)	-0.0336 (0.131)	0.0111 (0.137)	0.0266 (0.381)	-0.00760 (0.375)	0.0764 (0.388)	0.000611 (0.003)
Constant	-22.21* (11.877)	-21.82* (11.162)	-35.93*** (11.078)	9.349 (31.252)	13.99 (30.096)	-9.764 (30.244)	-1.011** (0.392)
Observations	228	228	228	224	224	224	224
$R^2$	0.45	0.42	0.44	0.40	0.38	0.39	0.23
Number of Communities	147	147	147	145	145	145	145
Time Trend	YES	YES	YES	YES	YES	YES	YES
Area Fixed Effects	YES	YES	YES	YES	YES	YES	YES

OLS, robust standard errors in parentheses clustered per community. Dependent: number of articles of each type.

In specification (1),(2) and (3), the dependent variable is the number of community governance rules.

In specification (4),(5), and (6) the dependent variable is the number of resource management rules.

In specification (7), the dependent variable is the fraction of community governance rules.

\*  $p < 0.10$ , \*\*  $p < 0.05$ , \*\*\*  $p < 0.01$

Table 8.14.

*Forward stability of the institution (uncensored observations)*

	(1)	(2)	(3)	(4)	(5)
Adjusted Surname Fractionalization	-7.173 (20.836)		-10.76 (20.438)	1.104 (20.421)	0.792 (22.472)
Adj. Surname Fract. × Assembly Size	-0.0647 (0.051)		-0.0406 (0.052)	0.291 (0.363)	0.525 (0.458)
Resource Fractionalization		-371.3* (196.843)	-358.2* (195.728)	-76.04 (291.091)	182.1 (306.345)
Villages within a community				-6.484 (4.570)	-6.104 (7.604)
Total attendants				-1.311 (1.684)	-2.483 (2.094)
Total productive surface				0.00250 (0.010)	0.0192 (0.013)
Charter amendment				59.69* (33.672)	19.61 (30.878)
Large commons endowment				24.14 (41.816)	41.09 (49.512)
Distance from closest local town				5.384 (3.204)	3.989 (2.950)
Constant	164.3*** (50.664)	340.5*** (109.525)	363.2*** (111.776)	143.3 (202.850)	-644.0** (309.201)
Observations	62	62	62	62	62
$R^2$	0.03	0.08	0.11	0.24	0.53
Number of Communities	40	40	40	40	40
Time Trend	NO	NO	NO	NO	YES
Area Fixed Effects	NO	NO	NO	NO	YES

OLS, robust standard errors in parentheses clustered per community.

Dependent: forward duration (in years).

\*  $p < 0.10$ , \*\*  $p < 0.05$ , \*\*\*  $p < 0.01$

Table 8.15.

*Quorums in assemblies*

	(1)	(2)	(3)	(4)	(5)	(6)
Adjusted Surname Fractionalization	0.0470 (0.031)			-0.0139 (0.038)		0.0310 (0.034)
Adj. Surname Fract. × Assembly Size	-0.000514* (0.000)			0.00218* (0.001)		-0.000470 (0.000)
Resource Fractionalization			-0.221 (0.145)	-0.185 (0.213)	-0.126 (0.212)	-0.120 (0.220)
Villages within a community				-0.00235 (0.007)	0.00463 (0.007)	0.00386 (0.008)
Total attendants		-0.000788 (0.001)		-0.00796** (0.004)	-0.00124 (0.001)	
Total productive surface				-0.0000250* (0.000)	-0.0000195 (0.000)	-0.0000200 (0.000)
Charter amendment				0.0107 (0.026)	0.0161 (0.027)	0.0192 (0.028)
Large commons endowment				0.0731** (0.036)	0.0796** (0.038)	0.0748** (0.037)
Distance from closest local town				0.00153 (0.003)	0.00180 (0.003)	0.00269 (0.003)
Constant	0.639*** (0.059)	0.731*** (0.029)	0.828*** (0.082)	0.519* (0.300)	0.595** (0.287)	0.580* (0.317)
Observations	91	91	91	91	91	91
Number of Communities	78	78	78	78	78	78
Log-likelihood	70.22	69.67	70.15	87.92	85.29	84.86
Time Trend	NO	NO	NO	YES	YES	YES
Area Fixed Effects	NO	NO	NO	YES	YES	YES

OLS, robust standard errors in parentheses clustered per community.

Dependent: quorum in assemblies.

\*  $p < 0.10$ , \*\*  $p < 0.05$ , \*\*\*  $p < 0.01$



All the model specifications reported in the section control for heteroskedasticity using cluster-robust standard errors, where the “cluster” is the community. With the computation of cluster-robust standard errors, it was assumed that covariance structures are homoscedastic within each community cluster; in addition, their implementation allows an additional correction for arbitrary serial correlation within clusters. Under these conditions, post-estimation testing for heteroskedasticity was considered superfluous.

The specifications mentioned in the following subsections were tested for multicollinearity by computing variance inflation factors (VIF). Variables having a VIF above 10 underline collinearity. In the selected specifications, the presence of multicollinearity is caused by the introduction of the interaction term  $SURN \times SIZE$  and involves only  $SIZE$ , the interaction term, and two are dummies. This potential problem almost disappears when the interaction is removed.<sup>196</sup>

First, the effects of social and resource heterogeneity on the dependents are reported and discussed. Size effects are commented on in a separate section.

### **8.3.1. Effects of social and resource heterogeneity**

**Complexity.** Table 8.9 reports the regression coefficients for analyses on *LENGTH*: Model (2) includes controls for area fixed effects and time trend and is our benchmark. Models (3) and (4) exclude surname fractionalization and total attendance, respectively.

The increase of both surname fractionalization and size has a positive impact on the length of the *Carte*, and the interaction term indicates that surname fractionalization has a decreasing trend with respect to the increase in size. A unit

---

<sup>196</sup> VIF tests are available upon request.

increase in adjusted surname fractionalization is correlated with an increase of seven articles of the average *Carta* when assembly size is smallest (zero).<sup>197</sup>

The number of villages is, instead, negatively correlated with the length of a charter: having one more village in the community organization leads to a decrease of almost three charter articles, and the effect is statistically significant. This latter result may be explained by historical evidence and is compatible with strategic incompleteness of social contracts: oftentimes, single villages had their own charters, and multi-village organizations may have had only a framework charter containing the discipline of the single village and a set of governance rules to coordinate the interaction of the villages; therefore, they are normally less detailed. On the contrary, charters of a single village tend to be more detailed in order to cope with local heterogeneities. Resource fractionalization is, instead, found to have no statistically significant effect.

In Table 8.10, the increase of adjusted surname fractionalization also is correlated with an increase of assembly roles. The interaction term with *SIZE* is negative, meaning that the trend is still decreasing but not statistically significant.<sup>198</sup>

Therefore, C1-1, that higher surname fractionalization generates more complexity, can be confirmed. Support for C1-2 is found; however, the effect is relevant only for the number of articles comprising the *Carta*. On the contrary, C1-3 receives no empirical support.

---

<sup>197</sup> In post-estimation testing, a linear combination of adjusted surname fractionalization and its interaction with the total number of attendants computes the total effect of surname fractionalization, returning a coefficient of 7.107 with a standard error of 3.298, significant at the 5% level: Filtering out the partial effect of assembly size from adjusted surname fractionalization did not change the result much.

<sup>198</sup> A test for the joint significance of adjusted surname fractionalization together with the interaction term with size returns a total effect of 0.6405 (s.e. 0.149), significant at the 1% level: Again, accounting for the partial effect of assembly size in adjusted surname fractionalization has not changed the overall result.

*Governance vs. resource management.* The analysis of the content of the rules follows and is substantially a breakdown of *LENGTH*.

In Table 8.12, the first three models report estimates for the dependent variable *GOVREG*, the absolute frequency of articles dealing with community governance. The benchmark equation is (1). The impact of surname fractionalization is positive and significant at the 5% level, and the impact is decreasing with the increase in size. This means that the impact of surname fractionalization on the number of governance rules is higher in smaller assemblies and smaller in larger assemblies.<sup>199</sup> This behavior was already noted in Table 8.9, and this may be due to the increase in the number of rules, regardless of the type, cannot be limitless also in case of complete fragmentation. The interpretation finds a visual confirmation in Table 8.11, which reports the number of governance and resource management rules in assemblies at high-, medium-, or low-surname fractionalization.

It is possible to notice how, in assemblies where surname fractionalization is lower, fewer community governance rules and fewer resource management rules are produced.

Models (4), (5), and (6) report estimates on *RESREG*, the frequency of resource management rules: the impact of surname fractionalization is weakly statistically significant. Importance is gained by the number of villages represented in the assembly, which exhibits a statistically significant negative effect on the number of resource management rules.

This, as anticipated, may also be explained by the fact that the technical aspects of land exploitation were disciplined by the *Carte* of the single villages, while

---

<sup>199</sup> The total effect of adjusted surname fractionalization and of its interaction with assembly size returns a coefficient of 2.814 (s.e. 1.214), significant at the 5% level in specification (1); in (4), the joint effect is 4.617 (s.e. 2.63), significant at the 10% level; in (7), the total effect is 0.88 (s.e. 0.324), significant at the 1% level.

the multi-village organization had the purpose of coordinating the villages together with the discipline of the single village where the assembly took place. Amendments to the complete *Carte* are, of course, of significantly shorter length.

Model (7) reports the most interesting result: surname fractionalization has a strong and positive significant impact on the percentage of governance rules set forth by the assembly, meaning that the more socially fragmented the assembly is, the greater the attention on the management of the group versus the management of the technical aspects of resource extraction. The assembly, on average, faces the adverse effects of social fragmentation with a more detailed discipline of the collective action in the institution rather than disciplining the quality-quantity of resource extraction and the related sanctions to avert the potential for the tragedy of the commons. The evidence found is compatible with this interpretation.

Surname fractionalization is stronger in governance rules (1) than in resource management rules (4), while the effect of the number of villages within a community is higher under resource management rules (4) than under governance rules (1).<sup>200</sup> Coordinating villages require rules on how to regulate resource extraction that are less detailed. Empirical support for the efficacy of this conjecture on effective levels of resource extraction cannot be provided due to lack of data. However, the historical evidence seems to point to the institutional result of a sustainable resource management.

In conclusion, C2-1 is confirmed: surname fractionalization impacts on the frequency of governance rules. Furthermore, surname fractionalization impacts also on the relative frequency of governance rules on the total of the provisions set forth by the assembly, underlining that the more the assembly is socially fragmented, the

---

<sup>200</sup> To allow the comparison of the effects, standardized coefficients are reported in Table 8.13 (Appendix D).

greater the importance of dedicating more detail to disciplining the governance of the group rather than the technical aspects of land exploitation. No empirical support was found for the hypotheses on the number of villages (C2-2) and on resource fractionalization (C2-3).

*Stability.* For a sample of 62 documents, including institutional changes before the end period (1807), it has been possible to compute the number of years before the next institutional change. Regression estimates exhibit no significant impact in any of the factors considered.

As shown in Table 8.14, resource fractionalization is weakly statistically significant. More resource-diverse communities are found to have institutions that are less enduring in (2) and (3); however, the significance of this effect disappears in (4) when other variables are added and eventually changes direction in (5) when time and area effects are added. In conclusion, no support could be found for any of the conjectures for stability, probably due to the limited number of observations of institutional change. Hence, the issue of institutional stability remains open to further inquiry.

*Consensus.* As to the analysis of the 91 assembly quorums, the benchmark model in Table 8.15 is (4). Surname fractionalization and resource fractionalization exhibit no statistically significant effect; therefore, no support is found for the conjectures stated in the previous section. Conclusively, even though neither social heterogeneity nor resource heterogeneity seem to play a role in affecting the difficulty in reaching a collective agreement in institutions, other effects appear to be relevant, each, thus, requiring its own subsection, as follows.

**8.3.2. Effects of group size.** From the statistical analyses, other independent variables have emerged as statistically significant. They are all related to size effects:

the number of assembly attendants, the total productive surface of the community where the assembly took place, and whether the community has a large endowment of commons. This subsection discusses these effects and seeks explanations for their presence.

**Complexity.** Regression coefficients in Tables 8.9 and 8.10 highlight statistically significant group size effects (number of attendants to the assembly) in determining the length of the *Carta* and the number of assembly roles. Both the effects are compatible with transaction costs considerations carried out in previous chapters and in general with the idea that transaction costs increase as the number of simultaneous interactants increases. The number of individual preferences that the *Carta* must reflect is higher in larger groups, and the general tendency seems to be writing more complete social contracts in larger groups. The number of different roles required to manage an institution involving a larger number of people reflect this complexity. After all, on this issue, Olson (1965) was right in stating:

...to establish a group agreement or organization will nonetheless always tend to be more difficult the larger the size of the group, for the larger the group the more difficult it will be to locate and organize even a subset of the group, and those in the subset will have an incentive to continue bargaining with the others in the group until the burden is widely shared, thereby adding to the expense of bargaining. (p. 46)

Although literature supports this statement, a breakdown of the analyses seems necessary.

**Governance vs. resource management.** Let us consider the analyses conducted on the content of regulation in Table 8.12. Group size effects are present both in the number of governance rules and in the number of resource management

rules, and the effects are in both cases positive and statistically significant. The analysis of standardized coefficients highlights the stronger impact of size in determining the number of governance rules (1) than in determining resource management rules (4), and this provides further support to the conjecture that larger groups require a higher number of governance rules for a sustainable management of their natural resources. Nevertheless, larger groups need more rules of resource management and, therefore, more complete social contracts, as exhibited by the positive and significant coefficient on the total number of attendants in (4).

*Stability.* As anticipated, regression coefficients in Table 8.14 do not show significant effects of any of the independent variables on the number of years preceding the next institutional change. A possible explanation may reside in the small size of the sample and the lack of additional data. Another analysis has been carried out on a subsample of 21 observations in order to investigate how the content of the rules may have an impact on the number of years the institution will last.

Standardized coefficients are reported for ease of immediate comparison in Table 8.16. Keeping as dependent the stability of the institution, a different regression is run for each of the rule categories available in the charters, with time trend, document length, and type of document controlled for. Eventually, quorum is also inserted among the independent variables to verify whether a high consensus has an impact on the stability of the institution. The regression coefficients exhibit that governance and resource management rules have opposite effects on the stability of institutions: while a higher proportion of governance rules and participation rules is associated with a lower institutional endurance, probably related to the need of frequent amendment, a higher proportion of resource management rules correlates with a significant increase in endurance. In all the specifications, quorum has a

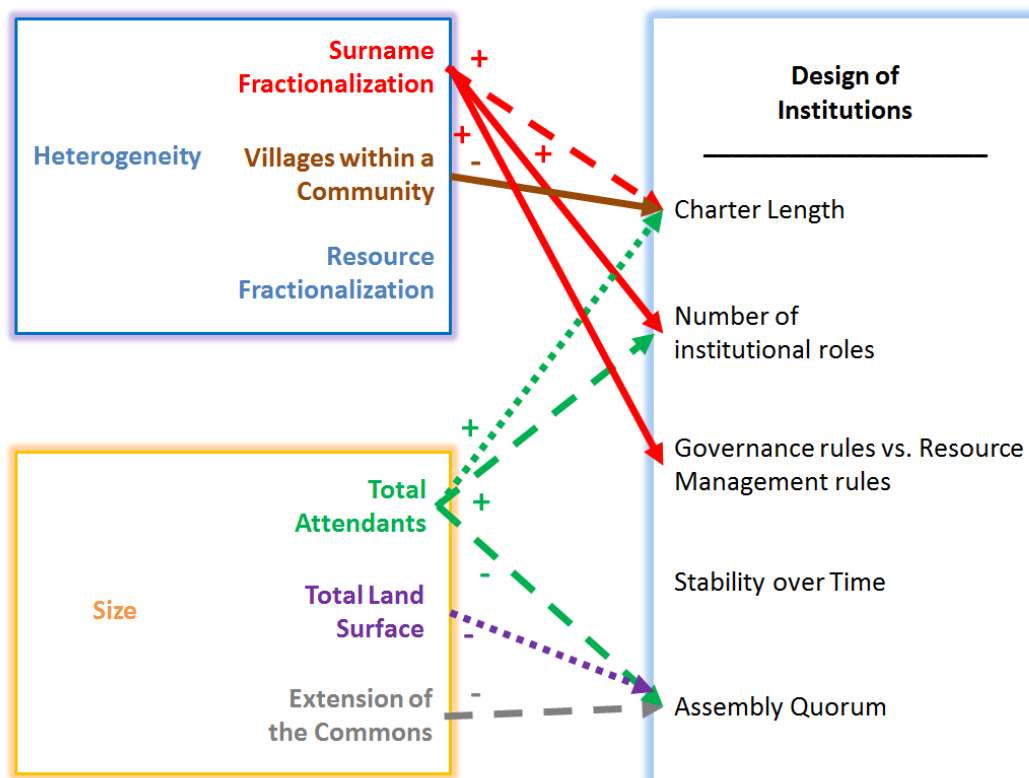
significant positive effect on the stability of the institution: a higher quorum equals a higher degree of consensus over the content of the institution deliberated by the assembly. Surprisingly, an increased consensus results in a higher institutional endurance; in the theory of voting behavior, one of the factors that might affect consensus is the size of the voting group.

*Consensus.* Group size, measured by the number of attendants to the assembly, has a significant effect on the deliberative quorum. The effect is, however, negative and significant at the 5% level. This fact underlines common knowledge in the literature on voting behavior in public policy: larger voting groups fail in reaching agreements due to the high costs of aggregating preferences. When a majority rule is set, the Condorcet paradox means that cyclical preferences toward voting alternatives are likely to emerge: the decision deadlock can be overcome, for example, by setting a lower deliberative quorum or by letting preference aggregation in subgroups that will act through a representative (that is, keeping the same quorum, while only few people will vote for the whole). In any case, the results for a large voting group are likely to be the following two: either they will be represented by a few members attending the assembly and casting a vote with a majority or even with supermajority rules (and figure as a small group) or they will decide with a lower quorum. This is exactly what the regression table displays in Table 8.15, model (4): as the number of attendants increases, the quorum decreases.

Lower quorums are required when the productive surface increases, while higher quorums are required when the productive surface is largely represented by commons. This observation leads to a first conclusion compatible with the evidence: in order to avert the tragedy of the commons, a larger consensus is required. Larger consensus is easy to obtain when the face-to-face group of interactants is smaller.



Recalling from the previous subsection that a higher quorum is related to a longer institutional endurance, a first conclusion is that the evidence found is compatible with the thesis that group size has an indirect impact on institutional endurance. This might explain why organizing collective action in smaller groups led, and is likely to lead, local communities to be successful in overcoming the tragedy of the commons.



*Figure 8.9.* A summary of the results.

*Note.* Solid lines represent statistical significance at the 1% level, dashed lines significance at the 5% level, dotted lines significance at the 10% level, and the sign indicates whether the effect has been found positive or negative.

#### 8.4. Conclusions

This chapter empirically investigated a long-debated issue in political theory: how the design and stability of institutions may reflect the characteristics of the group that agreed on them. Specifically, the focus of the study has been on understanding how social heterogeneity, resource heterogeneity, and group size may affect institutional design and stability. The *Carte Di Regola* offered a setting for the empirical study of this phenomenon over the long term.

Empirical methodologies and an unusually large dataset allowed the empirical analysis of institutions in a novel way under two main aspects. First, this study observes similar institutions (the *Carte*) in several village communities over a period of six centuries (1245–1801), in a well-delimited region with stable political characteristics and in an environment with heterogeneous resource endowments. Second, it develops a long debated issue in institutional analysis: the role of heterogeneity and group size as conditions that affect successful collective action of groups in common-pool resource management systems. The empirical strategy adopted was not completely novel and, together with the consideration of each assembly as a single and independent event, facilitated disentangling of potential endogeneity issues regarding institutional formation.

Two sections discussed proxies of social heterogeneity and of resource heterogeneity: social heterogeneity is measured using a fractionalization index based on the surnames of assembly attendants; resource heterogeneity is measured using a similar fractionalization index computed on categories of land resources from a historical land register. The subsections also discuss the properties of these measures, and light is shed on the limitations by means of two Monte Carlo simulations.

A specific section describes five institutional features that are considered relevant for institutional design: (i) the length of the *Carte* and (ii) the number of roles in the assembly, considered proxies of the complexity of institutions; (iii) the frequency of governance rules and of resource management rules, and the importance of governance rules relative to the total; (iv) the number of years before the next institutional change, as a proxy of institutional stability; (v) the consensus required to reach the collective decision on the institution.

Ten findings summarize the present research effort, and are visually represented in Figure 8.9.

The following six findings concern the impact of social and resource heterogeneity. First, that higher surname fractionalization generated more institutional complexity, both in terms of the length of the *Carte* and in terms of the number of assembly roles required for community governance. Second, that the number of villages represented in the assembly displayed a negative correlation with document length. One possible interpretation for this finding is that multi-village communities preferred writing “incomplete” or framework-oriented social contracts. This left the single villages with the task of crafting more detailed documents to govern collective action and dealing with local heterogeneities. Third, that surname fractionalization had a significant and positive impact on the frequency of community governance rules. The effect was stronger on the frequency of community governance rules than on the frequency of resource management rules. The impact of surname fractionalization on community governance rules was stronger when surname fractionalization increased in small communities. Fourth, that surname fractionalization also had a significant impact on the ratio of community governance rules to the total number of rules. This result is non-obvious and underlines that the

more socially fragmented the assembly was, the less attention was placed on disciplining technical aspects of resource extraction. Fifth, that social and resource heterogeneity exhibited no significant impact on the stability of institutions. The assembly quorum appears to be unaffected by surname fractionalization. Sixth, that none of the five institutional features revealed a significant correlation with resource heterogeneity.

The last part of the analysis was devoted to assessing the impact of size effects on institutional features, and led to the following four findings. First, that group size had positive and significant effects on institutional complexity: larger assemblies represented a multifaceted agglomerate of different individual preferences, required more specialized governance, and were reflected in more detailed social contracts. This result was further confirmed in the analysis of the frequency of community governance rules vis-à-vis resource management rules. Second, that larger groups required more governance rules for a sustainable management of their natural resources. Third, that an increased consensus correlates with a higher institutional endurance. Fourth, a larger group size has a negative impact on the deliberative quorum.

Overall, the evidence here presented is compatible with the arguments in previous chapters concerning the determinants and the limits of group size in institutional collective action.

The present chapter contains limitations common in empirical research with archival data and in the empirical study of institutions. Additional data from case studies in different regions will be beneficial for testing the external validity of the conclusions.

## Chapter 9. Conclusion

### 9.1. Introduction

This study explored the relationship between group size and institutional change. The research made use of a six-century long database concerning the collective action on the commons of hundreds of villages in the Italian Alps.

According to economic theory, when multiple users have access to a common resource and there are no property rights, each individual wants to extract the maximum benefit and bear only a minimal share of the total cost of extracting the resource. This social dilemma may end in the complete disruption of the common resource and lead to a tragedy of the commons (Gordon, 1954; Hardin, 1968). Ostrom (1990) challenged this idea by demonstrating that some groups are able to overcome the tragedy of the commons by setting up institutions for collective action. In such institutions, users of a common resource coordinate their extraction efforts and cooperate over the long run for the sustainable use of their common resources (Ostrom et al., 1992).

In several articles and books (e.g., Ostrom 2005b; Poteete et al., 2010; Varughese & Ostrom, 2001), Ostrom identified a lack of research into group size and group heterogeneity in the theoretical and empirical analysis of institutions created for collective action. The present study sought to fill this theoretical and empirical gap within this stream of research.

Although it is recognized that common property was the primordial form of ownership in many early societies, a search of the literature revealed a longstanding, ongoing debate among European economic and legal scholars<sup>201</sup> about common

---

<sup>201</sup> This debate is discussed in Chapter 2.

property's importance in legal theory and whether it is an aberration from the private property paradigm (Grossi, 1981; Hume, 1739; Laveleye, 1891; Maine, 1861). With Ostrom's *Governing the Commons* (1990), this debate emerged as one of the most promising research subjects in institutional analysis, both in relation to the specific domain of the commons and as a result of the innovative interdisciplinary methodologies.

The present study assumed there was a group of appropriators of the commons (Chapter 1) and that this group has to decide whether extraction (identified as a collective action problem) be performed directly under an informal institution or indirectly under a formal institution. The group's engagement in a formal regime requires an additional collective action: participating in the creation of self-enforcing institutions for the appropriation of a sustainable amount of commons. This study tested the threshold hypothesis, which predicted that the transition from an informal to formal institution is driven by cognitive limits that determine a threshold group size.

The threshold hypothesis (Chapter 4) was broken down into three sub-problems, which are discussed in three separate empirical chapters. Chapter 5 investigates group size threshold and its determinants. Chapter 6 examines whether the institutional phenomena of group fission and fusion occur after crossing the threshold. Chapter 8 investigates the role of group and resource heterogeneity in the design of formal institutions. Chapter 8 deals with a specific domain, and it is preceded by an introductory chapter that contains a discussion about the role of group heterogeneity in the design and stability of institutions (Chapter 7).

This study used original datasets about the historical case of the Carte di Regola in the Italian Alps<sup>202</sup> region from the early 13th century until the French

---

<sup>202</sup> A discussion about data sources and documentation is found in Chapter 3.

invasion of the region in 1796.<sup>203</sup> This case was first studied by Casari (2007) to understand the reasons for the emergence of “institutions that protected property rights and regulated their use in the commons” (p. 191). The present study suggests the relevance of group size in the transition from informal to formal regimes, based on new historical evidence in addition to the one collected in Casari (2007)<sup>204</sup>. New research questions were formulated, and statistical analyses were carried out on additional legal documents, and sources on population, household size, land resources, climate and topography.<sup>205</sup> This evidence was used to test the research hypothesis by examining variations in group size and heterogeneity in a large sample of villages observed over six centuries.

The analysis in this study was based on two main assumptions: (a) the independence of groups, which are assumed to have the ability to move from an informal institution to a formal institution without any external influence (i.e., from local aristocracy); and (b) the exogeneity of population size from the process of institutional change, under the *ceteris paribus* condition. Other minor assumptions and elements of the research method were specific to each of the three research questions derived from the threshold hypothesis.<sup>206</sup>

The remainder of this chapter is structured as follows. Section 9.2 provides a synthesis of the empirical findings for the whole study and for each specific chapter. Section 9.3 illustrates the theoretical implications of this study’s findings, and Section 9.4 identifies areas that may be useful for creating policy. Section 9.5 outlines directions for future research. Section 9.6 contains conclusions about the present study.

---

<sup>203</sup> Chapter 2 provides a detailed historical background of the case.

<sup>204</sup> The reader is addressed to Appendix B for a replication of Casari’s (2007) study.

<sup>205</sup> Chapter 3 contains a detailed description of sources and documentation of the research.

<sup>206</sup> Please refer to the specific sections in Chapter 1.

## 9.2. Empirical Findings

There was theoretical and empirical support for the hypothesis that group size threshold promotes a change from informal to formal institutions.

Initial evidence about the empirical relevance of group size in the emergence of formal institutions was already suggested by Casari's (2007) data. It was important to investigate the robustness and the reason for this finding. For instance many communities were founded later than 1200; however, the datation of the first settlement was found to be historically imprecise for the purposes of the empirical analyses turned out to be and statistically irrelevant. Instead, historical evidence showed how large communities were, for the most part, groups of villages. After some time most of them engaged in fission behavior. That is, they split up their organization into two or more institutional entities.

One key finding was the following. An inspection of the trend in regional population and average community size revealed an interesting fact: from 1200 to 1800, the total population of the area increased about three times, while the average population size of communities remained stable.

The empirical findings are articulated around three specific questions on: "Group size thresholds in institutions" (Chapter 5), "Group Fission and Fusion in Institutions" (Chapter 6) and "Effects of group heterogeneity and size on institutional design" (Chapter 8). A synthesis of the key arguments and findings is provided in the following subsections for each of the three research questions used to test the threshold hypothesis.

**9.2.1. Existence of a threshold group size in institutional change.** This chapter investigated five factors potentially determining the size of groups for successful collective action: (1) resource specificity, (2) free-riding, (3) transaction



costs, (4) heterogeneous individual preferences, and (5) cognitive limits. For each factor, testable arguments were developed. Strong empirical support was found for the cognitive limits argument, and the empirical threshold in group size estimated on the data is about 183 or 170 individuals in the group, depending on which data sample is used (all communities or single-layer communities).

The linear fit was stable throughout the observation period. Threshold values of 198 and 155 individuals were obtained for the full charter sample by computing the mean and median of appropriators, respectively. In non-charter groups, an upper bound was identified at a median of 231 individuals, and this threshold was also stable over time. These group size thresholds, interestingly, were in the range of 100 to 231 individuals found by British evolutionary anthropologist Robin Dunbar (1993a) in his research about primate and human societies.

The results of computer simulations of the sample showed that the present study's findings strongly supported the threshold hypothesis. These analyses also revealed the following: (a) group size was not resource-specific; (b) large groups may have been successful, but they used different institutional technologies to succeed; (c) group size differences were attributable to different transaction costs; and (d) large groups reached agreements using a direct vote with lower quorums because it is difficult to accommodate the preferences of a large group of people in a common course of action.

### **9.2.2. Group fission and fusion as behavioral responses to the threshold.**

One puzzling finding was that some communities had a size far larger than the predicted by the threshold hypothesis. A close inspection of these cases revealed they were communities made up of more than one village, adopted institutional arrangements, and underwent significant organizational changes similar to the

changes reported in primate social groups (Aureli et al., 2008). For example, collective action in large groups was handled by subgroups organized in no more than four organizational layers. It was found that the size of stand-alone villages remained in Dunbar's group size range throughout the period, while the population of face-to-face units in multi-village organizations significantly increased between the first and last institutional change. The population of face-to-face units and the population of a control group of stand-alone villages observed at the last institutional change did not differ significantly.

The process of institutional change was observed in all the case studies, which ranged from the fusion of small villages to several types of fission of large communities into smaller units or clusters. These changes were ordered in a sequence of increasing transaction costs, and it was found that this sequence was related to the group size of face-to-face units in multi-village organizations:<sup>207</sup> the different types of fission events range over a spectrum where independence is obtained only by smaller multi-village communities up to ca. 1,000 inhabitants, while other fission events involving clustering and coexistence and pure coexistence occurred along the whole spectrum in multi-village communities.<sup>208</sup>

### **9.2.3. Social and resource heterogeneity in groups crossing the threshold.**

The present study also examined the relationship among social and resource heterogeneity, group size, and institutional change and design in groups adopting a formal regime. Individual surnames were examined to discover internal group characteristics that indicated the social fragmentation of assemblies. The diversity of groups was also measured in terms of their portfolio of natural resources and the variation of institutional design obtained from the systematic coding of a rich body of

---

<sup>207</sup> Figures 6.6–6.7, Appendix C.

<sup>208</sup> The reader is addressed to Appendix A for a succinct definition of these concepts.

documents. This analysis was conducted to discover whether social and resource heterogeneity and group size had an impact on specific features of institutional design: (a) complexity, (b) the importance of governance and resource management rules in the documents, (c) the importance of governance rules in the charters, (d) the number of years before the next institutional change as a proxy for institutional stability, and (e) the level of consensus required to reach a collective decision about the institution. In addition, the analysis examined whether the effect of social heterogeneity was stronger than the effect of resource heterogeneity.

Computer simulations were used to investigate the statistical consequences of the relationship between group size and the index of fragmentation employed in the research. The empirical analysis was aimed at untangling potential endogeneity issues in this relationship and empirical analysis of the role of social and resource heterogeneity in relation to institutional design. The results provided by the regression analysis were intuitive only in part.

First of all, all five institutional features considered by this study were found to have no significant correlation to resource heterogeneity, which was, thus, determined to be almost redundant. On the contrary, social heterogeneity had significant impacts, especially on institutional complexity, consensus, and the relative importance of governance versus resource management rules.

The results of this analysis show that high degrees of social fragmentation were associated with higher institutional complexity. This was verified by observing the relationship between surname variety within a group and the length of the Carte or number of assembly roles. Multi-village communities were associated with shorter charters. This—perhaps less intuitive—result suggested that social contracts for larger organizations are merely frameworks that enable single villages to enact a more

detailed document at the local level and deal more effectively with local heterogeneities. Less obvious results were obtained when observing the relationship between surname fragmentation and the content of the Carte. Greater surname fragmentation is associated with more community governance rules. Finally, the impact in smaller communities is larger than that in larger communities relative to the frequency of resource management rules and when there is more surname fragmentation. This result was not obvious, because it supported the idea that socially fragmented assemblies facing the risk of the tragedy of the commons placed more emphasis on community governance than on the technical aspects of resource extraction. The analysis of the impact of social and resource heterogeneity on the duration of institutions produced unsatisfactory results. The regression produced non-significant statistics, showing that none of the factors had an impact on institutional stability.

The results did show that assembly size was significantly correlated to institutional design. Larger assemblies were associated with institutional designs that were more complex. This finding may indicate that larger groups need a functional specification of governments: complete social contracts are preferred as an ex ante investment to cope with the foreseen contingencies of community governance. In addition, it was found that larger groups tend to make decisions with lower quorums, which suggests it is easier to obtain a consensus in a small assembly than in a large assembly.

### **9.3. Theoretical Implications**

That institutional change is driven by group size thresholds suggests that cognitive limits and transaction costs could be usefully included in the theory of sustainable resource management. This implication was, to some extent, alluded to in

the empirical literature. However, the inclusion of group size thresholds in institutional change required a critical rethinking of how group characteristics affect the allocation of property rights in alternative institutional regimes (Williamson, 1979).

A search of the literature revealed a fragmented body of research with contrasting results and inconclusive answers, as if there were a missing link in defining and investigating the theoretical implications stated above. In Chapter 4, it is suggested that a critical reading of selected works in the biological and cognitive sciences combined with the predictions of the New Institutional Economics school of thought (Alchian & Demsetz, 1972; Coase, 1960; North, 1990; Williamson, 1979) provide rich theoretical insights for the economic and legal understanding of institutional change. For example, institutional change can be explained by a cognitive limitation in the number of social contacts that each individual can handle in face-to-face interactions. This cognitive limit implies at least four consequences:

- (1) It involves the existence of a fixed limit to group size at which face-to-face interactions may successfully occur (Chapter 5). The existence of these limits is related to the idea that interaction always bears a transaction cost because the human brain can process only a certain amount of information. Institutional change driven by cognitive limits was tested against other factors, and the evidence supported the threshold hypothesis (e.g., Dunbar 1993a).
- (2) When social groups that interact face-to-face increase in size, there can be organizational changes that involve the fission into multiple groups (Bickart et al., 2011; Dunbar, 2003, 2012; Hill & Dunbar, 2003; Stiller & Dunbar, 2007; Zhou et al., 2005). The response to a change in group size,

fission or fusion, is not a one-step decisions, but entails gradual transformations of the institutions, which most likely is influenced by transaction cost minimization (Chapter 6).

- (3) It can account for the transition of groups from an informal to a more formal institution. A formal institution can lower transaction costs using a different legal “technology”: the adoption of a formal institution, or structuring the organization in several layers, are ways to overcome a cognitive limitation. Hence, the process of evolution and allocation of property rights can be interpreted as behavioral responses of the group when individuals approach their cognitive limit.
- (4) It is compatible with the economic theory of property rights and institutions. The likely institutional type for the allocation of property rights depends on transaction costs (Barzel, 1997; Ellickson, 1991; North, 1990; Williamson, 1979, 1981) and the fit with the enforcement of informal and formal resource use rules that are aimed to maximize revenues from production<sup>209</sup>. The synthesis model in Chapter 6 was used to illustrate the relevance of transaction costs for institutional change in relation to the optimal use of common resources by a group. In this model, if transaction costs were zero, institutional changes would be irrelevant for the economic outcome. It is also true, however, that for the optimal resource use condition to hold in the model, regardless of group size, that transactions bear a cost is essential. Without considering transaction costs, the problem of allocating property rights for common resources would be meaningless. On the other hand, not only has the empirical evidence

---

<sup>209</sup> See Chapter 6 for a discussion about the compatibility of the informal theoretical model of institutional change with the empirical evidence contained in Chapters 5 and 6 and the theoretical predictions suggested in Chapter 4

discovered in the present study shown how considering transaction costs helps explain the institutional changes that occurred over time, but it also revealed the relevance of group size as a primary institutional factor in sustainable resource governance relative to technical resource management.

The results in Chapters 5 and 6 suggest there is a relationship between human cognitive limits and institutional change. These cognitive limits are a natural part of people's information processing capabilities and, therefore, affect the human capacity to solve collective action problems and interact efficiently in environmentally challenging settings. The adoption of fission and fusion strategies, for instance, allows people to overcome these limits with an efficient internal structure in informal and formal groups alike. This argument has been used in these chapters to suggest that the threshold hypothesis can be applied generally to economic institutions and organizations that involve self-governance.

#### **9.4. Policy Implication**

The results of the present study support the threshold hypothesis in collective action, which provides a potential explanation for the role of group size and heterogeneity in institutional design and stability. As a result, it may be possible to develop effective sustainability policies for institutions and organizations that allow self-governance.

The results discussed in Chapter 8 might explain why organizing collective action in small groups is likely to lead local communities to institutional success and, ultimately, to a sustainable management of their common resources. This evidence is compatible with the arguments in previous chapters concerning the determinants and

limits of group size in institutional collective action. The results also suggest that group size may have an indirect impact on institutional endurance.

The results discussed in Chapter 8 show how institutional design changes in response to group characteristics (e.g., social fragmentation) are associated with transaction costs. In spite of Olson's (1965) prediction that "the larger the group the farther it will fall short of providing an optimal amount of good" (p. 36), social heterogeneity and group size are key factors that should be carefully considered when designing institutions or organizations that can help large groups achieve environmental sustainability. While this research may be applicable in many regions of the world where the sustainable self-governance of common resources by local communities is crucial, potential implementations of the threshold hypothesis can also be extended to the management of collective action in large organizations in general, from businesses to cities. The threshold hypothesis may inform strategies aimed at the minimization of organization costs. By providing additional dimensions for predicting when organizational changes should occur, the hypothesis may be helpful in designing (and/or instigating) efficient changes pre-emptively.

### **9.5. Limitations and Recommendations for Future Research**

Further research will be necessary to strengthen the external validity of the conclusions drawn in the present research. There are two main limitations in the findings.

First, the findings rely on evidence from a single case study: the *Carte di Regola* in the Trentino Region. Although the analyses are carried out on hundreds of communities, a different case study could have led the researcher to different conclusions.



Second, this study's conclusions are based on historical data. Although the period considered covers six centuries, subsequent technological progress – like the diffusion of modern communication technologies – may render the findings unapplicable to some institutions and organizations in industrialized countries while retaining their validity in more traditional settings.

The following topics should be examined in future studies to validate the present study's findings and produce a more comprehensive theory about group size, institutional change, and the management of common resources:

- Research should be conducted that examines whether and when informal regimes are superior to formal regimes in terms of total welfare. This research should attempt to answer the question about whether, all other things being equal, the cognitive trigger leads to superior economic outcomes. Further data would be needed to build response variables that can capture welfare variations; ideally, this study would use the same case study examined in the present study.
- Research should be conducted to discover if the allocation of property rights on the commons has been influenced by group size (i.e., the threshold hypothesis) in diverse contexts. This type of research would require fieldwork and experiments in present-day societies and historical research, and it could provide external validity for the findings of the present study.
- Literature from the behavioral, organizational, and legal sciences should be reviewed to identify group size thresholds and fission–fusion strategies.

## **9.6. Conclusion**

Although group size and group heterogeneity in collective action on common resources are considered empirical and theoretical challenges, it is necessary to understand them in order to understand the organization and evolution of institutions. As an answer to Williamson (1979), the empirical testing of the threshold hypothesis, as a possible solution to the problem of group size and group heterogeneity, does show that transactions are affected by group size and limited cognition. This information may be useful when developing future sustainability and organizational change policies.

## References

- Abreau, D., Pearce, D., & Stacchetti, E. (1990). Toward a theory of discounted repeated games with imperfect monitoring. *Econometrica*, *58*(5), 1041–1063.
- Acemoglu, D., Cantoni, D., Johnson, S., & Robinson, J. A. (2011). The consequences of radical reform: The French Revolution. *American Economic Review*, *101*(December), 3286–3307.
- Acemoglu, D., & Johnson, S. (2005). Unbundling institutions. *Journal of Political Economy*, *113*(5), 949–995.
- Acemoglu, D., Johnson, S., & Robinson, J. A. (2001). The colonial origins of comparative development: An empirical investigation. *American Economic Review*, *91*(5), 1369–1401.
- Adhikari, B., & Lovett, J. C. (2006). Institutions and collective action: Does heterogeneity matter in community-based resource management? *Journal of Development Studies*, *42*(3), 426–445.
- Agrawal, A. (1998). Group size and successful collective action: A case study of forest management institutions in the Indian Himalayas. In C. Gibson, M. A. McKean, and E. Ostrom (Eds.), *Forest resources and institutions* (2000 ed., pp. 1–17). Rome: FAO.
- Agrawal, A., & Chhatre, A. (2006). Explaining success on the commons: Community forest governance in the Indian Himalaya. *World Development*, *34*(1), 149–166.
- Agrawal, A., & Goyal, S. (2001). Group size and collective action: Third-party monitoring in common-pool resources. *Comparative Political Studies*, *34*(1), 63–93.

- Agnoletti, M. (1993). Gestione del bosco e segagione del legname nell'alta valle del Piave. In G. Caniato (Ed.), *La via del Fiume dalle Dolomiti a Venezia* (pp. 73–126). Verona: Cierre Edizioni.
- Ahlerup, P., & Olsson, O. (2012). The roots of ethnic diversity. *Journal of Economic Growth*, 17(2), 71–102.
- Aiello, L. C., Wynn, T., Coolidge, F. L., Engle, R. W., Beaman, C. P., Barnard, P. J., ... Wadley, L. (2010). Working memory: Beyond language and symbolism. *Current Anthropology*, 51(June), Supplement 1.
- Akerlof, G. A. (1970). The market for “lemons”: Quality uncertainty and the market mechanism. *Quarterly Journal of Economics*, 84(3), 488–500.
- Alchian, A. A. (1965). Some economics of property rights. *Il Politico*, 30(4), 816–829. Reprinted in A. A. Alchian (1977). *Economic forces at work*. Indianapolis, IN: Liberty Press.
- Alchian, A. A. (1987). “Property rights.” In *The new Palgrave: A dictionary of economics*. New York: Norton.
- Alchian, A. A., & Demsetz, H. (1972). Production, information costs, and economic organization. *American Economic Review*, 62(5), 777–795.
- Alesina, A., Devleeschauwer, A., Easterly, W., & Kurlat, S. (2003). Fractionalization. *Journal of Economic Growth*, 8(2), 155–194.
- Alesina, A., Easterly, W., & Baqir, R. (1999). Public goods and ethnic divisions. *Quarterly Journal of Economics*, 114(4), 1243–1284.
- Alesina, A., & La Ferrara, E. (2000). Participation in heterogeneous communities. *Quarterly Journal of Economics*, 115(3), 847–904.
- Alesina, A., & La Ferrara, E. (2005). Ethnic diversity and economic performance. *Journal of Economic Literature*, 43(3), 762–800.

- Alfani, G. (2011). Le partecipanze: il caso di Nonantola. In G. Alfani and R. Rao (Eds.), *La gestione delle risorse collettive in Italia settentrionale, secoli XII-XVII*. Milano: Franco Angeli.
- Allen, D. W. (2000). Transaction costs. In B. Bouckaert and G. De Geest (Eds.), *Encyclopedia of law and economics* (pp. 893–926). Cheltenham: Edward Elgar.
- Allen, D. W., & Lueck, D. (2002). *The nature of the farm: Contracts, risk and organization in agriculture*. Cambridge: MIT University Press.
- Allison, P. D. (1984). *Event history analysis*. London: Sage.
- Anderson, Terry L., and P. J. Hill (1975) The Evolution of Property Rights: A Study of the American West. *Journal of Law and Economics* 18(1), 163–79.
- Andreatta, G., & Pace, S. (1981). *Trentino, autonomia e autogoverno locale*. Trento: Saturnia.
- Andreolli, B. (1995). Per una campionatura delle rivolte contadine e rurali nel Trentino medievale. In Cherubini G., ed. (1994). *Protesta e rivolta contadina nell'Italia medievale* (p. 268). Bari: Edizioni Dedalo.
- Annett, A. (2001). Social fractionalization, political instability, and the size of government. *IMF Staff Papers*, 48(3), 561–592.
- Aoki, M. (2007). Endogenizing institutions and institutional changes. *Journal of Institutional Economics*, 3(1), 1.
- Archetti, M. (2009). The volunteer's dilemma and the optimal size of a social group. *Journal of Theoretical Biology*, 261(3), 475–80.
- Archivio di Stato di Trento (1780). *Serie catasti teresiani*. Trento.
- Arrow, K. J. (1950). A difficulty in the concept of social welfare. *Journal of Political Economy*, 58(4), 328–346.

- Arrow, K. J. (1951). *Social choice and individual values* (1st ed.). New Haven: Yale University Press.
- Aumann, B. R. J., & Dreze, J. H. (1963). Cooperative games with coalition structures. *International Journal of Game Theory*, 3(4), 217–237.
- Aureli, F., Schaffner, C. M., Boesch, C., Bearder, S. K., Call, J., Chapman, C. A., ... van Schaik, C. P. (2008). Fission–fusion dynamics: New research frameworks. *Current Anthropology*, 49(4), 627–654.
- Axelrod, R., & Keohane, R. O. (1985). Achieving cooperation under anarchy: Strategies and institutions. *World Politics*, 38(1), 226–254.
- Axelrod, R. M. (1984). *The evolution of cooperation*. New York: Basic Books.
- Ayres, I., & Gertner, R. (1989). Filling gaps in incomplete contracts: An economic theory of default rules. *Yale Law Journal*, 99, 87–130.
- Baland, J.-M., & Platteau, J. (1996). *Halting degradation of natural resources: Is there a role of rural communities?* Oxford: Oxford University Press.
- Baland, J.-M., Pranab, B., Das, S., Mookherjee, D., & Sarkar, R. (2006). Managing the environmental consequences of growth: Forest degradation in the Indian Mid-Himalayas. *India Policy Forum, Global Economy and Development Program, The Brookings Institution*, 3(1), 125–277.
- Baldassarri, D., & Grossman, G. (2011). Centralized sanctioning and legitimate authority promote cooperation in humans. *Proceedings of the National Academy of Sciences of the United States of America*, 108(27), 11023–11027.
- Bandiera, O., Barankay, I., & Rasul, I. (2005). Cooperation in collective action. *Economics of Transition*, 13(3), 473–498.
- Banerjee, A., Iyer, L., & Somanathan, R. (2008). Public action for public goods. In T. P. Schultz & J. A. Strauss (Eds.), *Handbook of development economics* (pp.

- 3117–3154). Amsterdam: Elsevier.
- Banner, S. (2002). Transition between property rights regimes. *Journal of Legal Studies*, 31, 359–371.
- Bardhan, P. K. (1973). Size, productivity, and returns to scale: An analysis of farm-level data in Indian agriculture. *Journal of Political Economy*, 81(6), 1370–1386.
- Barros, D. B. (2008). Group size, heterogeneity, and prosocial behavior: Designing legal structures to facilitate cooperation in a diverse society. *Cornell Journal of Law and Public Policy*, 18, 203–221.
- Bartlett, M. (1947). The use of transformations. *Biometrics*, 3(1), 39–52.
- Barzel, Y. (1982). Measurement cost and the organization of markets. *Journal of Law and Economics*, 25(1), 27–48.
- Barzel, Y. (1997). *Economics analysis of property rights*. New York: Cambridge University Press.
- Barzel, Y. (2001). *A theory of the state: Economic rights, legal rights, and the scope of the state (political economy of institutions and decisions)*. New York: Cambridge University Press.
- Becker, G. S. (1968). Crime and punishment: An economic approach. *Journal of Political Economy*, 76(2), 169.
- Bellabarba, M., & Olmi, G. (Eds.) (2000). *Storia del Trentino -IV -L'età moderna*. Bologna: Il Mulino, Istituto Trentino di Cultura.
- Bellettini, A. (1987). *La popolazione italiana: Un profilo storico*. Torino: Einaudi.
- Bernheim, B. D., & Whinston, M. D. (1998). Incomplete contracts and strategic ambiguity. *American Economic Review*, 88(4), 902–932.

- Bezzi, Q. (1964). Le valli di Non e di Sole in un “Liber focorum” del 1350. *Studi Trentini di Scienze Storiche*, *XLIII*, 184–192.
- Bickart, K. C., Wright, C. I., Dautoff, R. J., Dickerson, B. C., & Barrett, L. F. (2011). Amygdala volume and social network size in humans. *Nature Neuroscience*, *14*(2), 163–4.
- Bikhchandani, S., Hirshleifer, D., & Welch, I. (1992). A theory of fads, fashion, custom, and cultural change as informational cascades. *Journal of Political Economy*, *100*(5), 1026.
- Bikhchandani, S., Hirshleifer, D., & Welch, I. (1998). Learning from the behavior of others: Conformity, fads, and informational cascades. *Journal of Economic Perspectives*, *12*(3), 151–170.
- Billor, N., Hadi, A. S., & Velleman, P. F. (2000). BACON: Blocked adaptive computationally efficient outlier nominators. *Computational Statistics & Data Analysis*, *34*(2), 279–298.
- Black, D., & Henderson, V. (1999). A theory of urban growth. *Journal of Political Economy*, *107*(2), 252–284.
- Bonabeau, E., Dagorn, L., & Fréon, P. (1999). Scaling in animal group-size distributions. *Proceedings of the National Academy of Sciences of the United States of America*, *96*(8), 4472–7.
- Bonazza, M. (2002). Fisco e finanza: Comunità, principato vescovile, sistema territoriale. In M. Bellabarba & G. Olmi (Eds.), *Storia del Trentino. Volume IV - Età Moderna* (pp. 319–362). Bologna: Il Mulino, Istituto Trentino di Cultura.
- Borgatti, S. P., Mehra, A., Brass, D. J., & Labianca, G. (2009). Network analysis in the social sciences. *Science*, *323*(April), 892–896.
- Bowden, G. R., Balaesque, P., King, T. E., Hansen, Z., Lee, A. C., Pergl-Wilson, G.,



- ... Jobling, M. A. (2008). Excavating past population structures by surname-based sampling: The genetic legacy of the Vikings in Northwest England. *Molecular Biology and Evolution*, 25(2), 301–309.
- Boyd, R., Gintis, H., & Bowles, S. (2010). Coordinated punishment of defectors sustains cooperation and can proliferate when rare. *Science*, 328(5978), 617–620.
- Boyd, R., Gintis, H., Bowles, S., & Richerson, P. J. (2003). The evolution of altruistic punishment. *Proceedings of the National Academy of Sciences of the United States of America*, 100(6), 3531–3535.
- Bromley, D. W. (1991). *Environment and Economy: Property Rights and Public Policy*. Oxford: Oxford University Press.
- Bromley, D. W. (1998). Determinants of cooperation and management of local common property resources. *American Journal of Agricultural Economics*, 80(3), 665–668.
- Brown, D. J. (1975). Aggregation of preferences. *Quarterly Journal of Economics*, 89(3), 456–469.
- Bryman, A. (2010). *Social research methods*. Oxford: Oxford University Press.
- Buchanan, J. M., & Tullock, G. (1962). *The calculus of consent*. Ann Arbor: University of Michigan Press.
- Cameron, C. A., & Trivedi, P. K. (2009). *Microeconometrics using Stata*. College Station, TX: Stata Press.
- Campbell, B., & Godoy, R. (1985). *Common-field agriculture: The Andes and medieval England compared*. Belfast: Queens University of Belfast, Geography Department., mimeo.
- Carley, K. (1991). A theory of group stability. *American Sociological Review*, 56(3),

331–354.

Carpenter, J. P. (2007). Punishing free riders: How group size affects mutual monitoring and the provision of public goods. *Games and Economic Behavior*, 60, 31–51.

Carter Hill, R., Griffiths, W. E., & Lim, G. C. (2011). *Principles of econometrics* (4th ed.). Hoboken, NJ: John Wiley & Sons.

Casari, M. (2007). Emergence of Endogenous Legal Institutions: Property Rights and Community Governance in the Italian Alps. *Journal of Economic History* 67(1), 191–226.

Casari, M., & Lisciandra, M. (2010). *Are gender biased inheritance systems evolutionary stable?* (Unpublished manuscript). University of Bologna, Bologna.

Casetti, A. (1961). *Guida storico archivistica del Trentino*. Trento: Collana di monografie della Società di studi per la Venezia Tridentina.

Castagnetti, A., & Varanini, G. M. (Eds.) (2004). *Storia del Trentino -III -L'età medievale*. Bologna: Il Mulino, Istituto Trentino di Cultura.

Castellani, C. (1982). *Tavole stereometriche e alsometriche costruite per i boschi italiani*. Villazzano (Trento): Istituto sperimentale per l'assestamento forestale e per l'apicoltura.

Casty, C., Wanner, H., Urg, J., Esper, J. A. N., & Ohm, R. B. (2005). Temperature and precipitation variability in the European Alps since 1500. *International Journal of Climatology*, 1880(October), 1855–1880.

Cesarini Sforza, L. (1914). *Per la storia del Cognome nel Trentino*. Trento: Casa Editrice Giovanni Zippei.

Chakravarty-Kaul, M. (1996). *Claiming the Alps: The Himalayan Commons in the*

- Punjab and Himachal Pradesh*. (Unpublished manuscript). Workshop in Political Theory and Policy Analysis, Indiana University, Bloomington.
- Chamberlin, J. (1974). Provision of collective goods as a function of group size. *American Political Science Review*, 68(2), 707–716.
- Cheung, S. N. S. (1969). *The theory of share tenancy, with special application to Asian agriculture and the first phase of Taiwan land reform*. Chicago: University of Chicago Press.
- Chiarotti, F. (2002). L'insurrezione contadina del 1525 nell'analisi degli avvenimenti dell'Anania. In M. Bellabarba & G. Olmi (Eds.), *Storia del Trentino. Volume IV -Età Moderna* (pp. 157–191). Bologna: Il Mulino, Istituto Trentino di Cultura.
- Chiocchetti, B. (1983). *Ambiente sociale e movimento demografico a Moena nel XVIII secolo*. (Unpublished laurea thesis). University of Padova, Padua.
- Chiocchetti, V., & Chiusole, P. (1965). *Romanità e Medioevo nella Vallagarina*. Rovereto: Manfrini Editori.
- Chung, T.-Y. (1991). Incomplete contracts, specific investments, and risk sharing. *Review of Economic Studies*, 58(5), 1031–1042.
- Ciresa, P., & Salvotti, F. (1978). *Economia e politica di una valle trentina: La Magnifica Comunità di Fiemme sec. XVI-XIX*. (Unpublished laurea thesis). University of Trento, Trento.
- Ciriacy-Wantrup, S. V., & Bishop, R. C. (1975). “Common property” as a concept in natural resources policy. *Natural Resources Journal*, 15, 713–727.
- Clark, C. W. (1990). *Mathematical bioeconomics: The optimal management of renewable resources* (2nd ed.). Vancouver: John Wiley & Sons, Inc.
- Clark, G. (1998). Commons sense: Common property rights, efficiency, and

- institutional change. *Journal of Economic History*, 18(1), 515.
- Coase, R. H. (1937). The nature of the firm. *Economica*, 4(16), 386.
- Coase, R. H. (1960). The problem of social cost. *Journal of Law and Economics*, (October), 26–27.
- Cohen, J., & Cohen, P. (1983). *Applied multiple regression/correlation analysis for the behavioral sciences*. Hillsdale, NJ: Lawrence Erlbaum Associates.
- Colantonio, S.E., Lasker, G. W., Kaplan, B. A., & Fuster, V. (2003). Use of surname models in human population biology: A review of recent developments. *Human Biology*, 75(6), 785–807.
- Cole, J. W., & Wolf, E. R. (1999). *The hidden frontier: Ecology and ethnicity in an Alpine valley*. Berkeley, CA: University of California Press.
- Commons, J. R. (1931). Institutional Economics. *American Economic Review*, 21(4), 648–657.
- Conlisk, J. (1996). Why bounded rationality? *Journal of Economic Literature*, 34(2), 669–700.
- Conrad, J. M. (2010). *Resource economics* (2nd ed.). New York: Cambridge University Press.
- Consiglio provinciale d'agricoltura pel Tirolo (1903). Tabelle sulle condizioni agricole – forestali – economiche. In *Bollettino del Consiglio provinciale d'agricoltura* (pp. 4–12). Trento: Monaumi.
- Coppola, G. (2002a). Agricoltura di piano, agricoltura di valle. In M. Bellabarba & G. Olmi (Eds.), *Storia del Trentino -IV -L'età moderna* (pp. 233–258). Bologna: Il Mulino, Istituto Trentino di Cultura.
- Coppola, G. (2002b). Il consolidamento di un equilibrio agricolo. In M. Bellabarba & G. Olmi (Eds.), *Storia del Trentino -IV -L'età moderna* (pp. 259–282).

Bologna: Il Mulino, Istituto Trentino di Cultura.

- Cornes, R., Mason, C. F., & Sandler, T. (1986). The commons and the optimal number of firms. *Quarterly Journal of Economics*, 101(3), 641–646.
- Cowan, N. (2000). The magical number 4 in short-term memory: A reconsideration of mental storage capacity. *Behavioral and Brain Sciences*, 24(1), 87–114, 114–85.
- Cox, S. J., Slockin, T. J., & Steele, J. (1999). Group size, memory, and interaction rate in the evolution of cooperation. *Current Anthropology*, 40(3), 369–376.
- Crocker, K. J., & Reynolds, K. J. (1993). The efficiency of incomplete contracts: An empirical analysis of air force engine procurement. *RAND Journal of Economics*, 24(1), 126–146.
- Crowley, G. R. (2011). *Testing rawls: Heterogeneity and constitutional choice*. (Unpublished manuscript). Manuel H. Johnson Center for Political Economy, Sorrell College of Business, Troy University, Troy.
- Curzel, E. (1999). *Le pievi trentine: Trasformazioni e continuità nell'organizzazione territoriale della cura d'anime dalle origini al XIII secolo*. Bologna: Edizioni Dehoniane Bologna.
- Curzel, E., Pamato, L., & Varanini, G. M. (2001). Giovanni da Parma, canonico della cattedrale di Trento, e la sua cronaca (1348–1377). *Studi Trentini di Scienze Storiche*, 80(2), 211–239.
- Darwin, G. H. (1875). Marriages between first cousins in England and their effects. *Journal of the Statistical Society of London*, 38(2), 153–184.
- De Alessi, L. (1983). Property rights, transaction costs, and X-efficiency: An essay in economic theory. *American Economic Review*, 73(1), 64–81.
- de Janvry, A., N. McCarthy, and E. Sadoulet (1998). Endogenous provision and ap-

- appropriation in the commons. *American Journal of Agricultural Economics*, 80(3), 658–664.
- De Laveleye, E. (1891). *De la propriété et de ses formes primitives*. Paris: Paris F. Alcan.
- De Moor, M., Warde, P. S., & Taylor, L. S. (Eds.) (2002). *Management of common land in North West Europe 1500–1850*. Turnhout: Brepols Publishers.
- De Moor, T. (2009). Avoiding tragedies: A Flemish common and its commoners under the pressure of social and economic change during the eighteenth century. *Economic History Review*, 62(1), 1–22.
- de Quervain, D. J.-F., Fischbacher, U., Treyer, V., Schellhammer, M., Schnyder, U., Buck, A., & Fehr, E. (2004). The neural basis of altruistic punishment. *Science*, 305(5688), 1254–8.
- Dahlman, C. J. (1979). The Problem of Externality. *Journal of Law and Economics*, 22(1), 141–162.
- Debiasi, L. (1953). Contributo allo studio della popolazione del Trentino nel XVII secolo. In C. E.-S. Trentino (Ed.), *Studi e Ricerche Storiche sulla Regione Trentina*. Padova: Stediv.
- Demsetz, H. (1967). Toward a theory of property rights. *American Economic Review*, 57(2), 347–359.
- Demsetz, H. (1968). The cost of transacting. *Quarterly Journal of Economics*, 82(1), 33–53.
- Diamond, J. M., & Robinson, J. A. (Eds.) (2010). *Natural experiments of history*. Cambridge, MA: Harvard University Press.
- Douglas, P. H. (1976). The Cobb–Douglas production function once again: Its history, its testing, and some new empirical values. *Journal of Political Economy*,

84(5), 903–916.

- Doupé, P. (2011). Ethnic diversity and village level institutions: Evidence from Indonesia under dictatorship and democracy. APSA 2011 Annual Meeting Paper.
- Du Cange, C. D. F. (1887). *Glossarium ad scriptores mediae et infimae latinitatis*. Paris: ELEC, Sorbonne.
- Duclos, J.-Y., Esteban, J., & Ray, D. (2004). Polarization: Concepts, measurement, estimation. *Econometrica*, 72(6), 1737–1772.
- Dunbar, R. I. M. (1992). Neocortex size as a constraint on group size in primates. *Journal of Human Evolution*, 20(March), 469–493.
- Dunbar, R. I. M. (1993a). Co-evolution of neocortex size, group size and language in humans. *Behavioral and Brain Sciences*, 16(4), 681–735.
- Dunbar, R. I. M. (1993b). Neocortex size, group size, and the evolution of language. *Current Anthropology*, 34(2), 184–193.
- Dunbar, R. I. M. (1998). The social brain hypothesis. *Evolutionary Anthropology*, 6, 178–190.
- Dunbar, R. I. M. (2003). Evolution of the social brain. *Science*, 302, 1160–1161.
- Dunbar, R. I. M. (2009). The social brain hypothesis and its implications for social evolution. *Annals of Human Biology*, 36(5), 562–72.
- Dunbar, R. I. M. (2012). The social brain meets neuroimaging. *Trends in Cognitive Sciences*, 16(2), 101–2.
- Dunbar, R. I. M., & Spoor, M. (1995). Social networks, support cliques, and kinship. *Human Nature*, 6(3), 273–290.
- Easterly, W. (2001). Can institutions resolve ethnic conflict? *Economic Development and Cultural Change*, 49(4), 687–706.

- Edney, J. J. (1980). The commons problem: Alternative perspectives. *American Psychologist*, 35, 131–150.
- Edney, J. J. (1981). Paradoxes on the commons: Scarcity and the problem of equality. *Journal of Community Psychology*, 9, 3–34.
- Eggertsson, T. (1990). *Economic behavior and institutions*. Cambridge: Cambridge University Press.
- Ellickson, R. C. (1991). *Order without law: How neighbors settle disputes*. Cambridge MA: Harvard University Press.
- Ellickson, R. C. (1993). Property in land. *Yale Law Journal*, 102, 1315–1400.
- Epiboli, A. (1977). *Ambiente sociale e movimento demografico a Borgo Valsugana nella seconda metà del Settecento*. (Unpublished laurea thesis). University of Padova, Padua.
- Erlei, M. (2008). Heterogeneous social preferences. *Journal of Economic Behavior & Organization*, 65(3–4), 436–457.
- Esteban, J., & Ray, D. (1994). On the measurement of polarization. *Econometrica*, 62(4), 819–851.
- Esteban, J., & Ray, D. (2001). Collective action and the group size paradox. *American Political Science Review*, 95(3), 663–672.
- Esteban, J., & Ray, D. (2011). Linking conflict to inequality and polarization. *American Economic Review*, 101(1974), 1345–1374.
- Fehr, E., & Gächter, S. (2000). Cooperation and punishment in public goods experiments. *American Economic Review*, 90(4), 980–994.
- Fehr, E., & Gächter, S. (2002). Altruistic punishment in humans. *Nature*, 415(6868), 137–40.
- Feinman, G. M. (2010). Size, complexity, and organizational variation: A



- comparative approach. *Cross-Cultural Research*, 45(1), 37–58.
- Fennel, L. A. (2011). Ostrom's law: Property rights in the commons. *International Journal of the Commons*, 5(1), 9–27.
- Ferrarese, A. (2005). Popolazione, famiglia e società a Volano. Evoluzione demografica e congiunture in una comunità della Vallagarina tra XVI e XIX secolo. In R. Adami, G. M. Varanini, & M. Bonazza (Eds.), *Volano. Storia di una comunità* (pp. 155–193). Rovereto: Nicolodi.
- Fiebiger, H. (1959), *Bevolkerung und Wirtschaft Sudtirols Bergisch Gladbach*, Heider Verlag, Fortes, Meyer.
- Field, B. C. (1985). The optimal commons. *American Journal of Agricultural Economics*, (May), 364–367.
- Field, B. C. (1989). The evolution of property rights. *Kyklos*, 42(3), 319–345.
- Forge, A. (1972). Normative factors in settlement size of neolithic cultivators (New Guinea). In P. J. Ucko, R. Tringham, & G. W. Dimbleby (Eds.), *Man, settlement, and urbanism* (pp. 363–376). London, UK: Duckworth.
- Franceschini, I. (2005). Comunità e risorse ambientali a Volano tra XV e XVIII secolo. In R. Adami, G. M. Varanini, & M. Bonazza (Eds.), *Volano. Storia di una comunità* (pp. 123–148). Rovereto: Nicolodi.
- Franceschini, I. (2009). Uomini e territorio a Pinè tra XV e XVIII secolo. In M. Bettotti (Ed.), *Storia di Piné: Dalle origini alla seconda metà del XX secolo* (pp. 223–334). Baselga di Piné (TN): Comune di Baselga.
- Fudenberg, D., & Maskin, E. (1986). The folk theorem in repeated games with discounting or with incomplete information. *Econometrica*, 54(3), 533–554.
- Gächter, S., Renner, E., & Sefton, M. (2008). The long-run benefits of punishment. *Science*, 322(5907), 1510.

- Gar, T. (1860). *Cronaca dei Vescovi di Trento (1022-1540)*. Trento: Monaudi.
- Garbellotti, M. (2006). *Le risorse dei poveri*. Bologna: Il Mulino.
- Garcia-Montalvo, J., & Reynald-Querol, M. (2002). *Why ethnic fractionalization? Polarization, ethnic conflict and growth*. (Unpublished manuscript). UPF Economics and Business Working Paper No. 660.
- Giacomoni, F. (1991). *Carte Di Regola e Statuti delle Comunità Rurali Trentine*. Milano: Edizioni Universitarie Jaca.
- Glaser, B. G., & Strauss, A. L. (1967). *The discovery of grounded theory: Strategies for qualitative research*. Hawthorne, NY: Aldine de Gruyter.
- Gneezy, U., & Rustichini, A. (2000). A fine is a price. *The Journal of Legal Studies*, 29(1), 1.
- Goio, R. (1978). *Ambiente economico-sociale e movimento demografico a Levico nella seconda metà del Settecento*. (Unpublished laurea thesis). University of Padova, Padua.
- Goldberger, A. (1991). *A course in econometrics*. Cambridge, MA: Harvard University Press.
- Gordon, S. H. (1954). The economic theory of a common-property resource: The fishery. *Journal of Political Economy*, 62(2), 124–142.
- Granovetter, M. S. (1978). Threshold models of collective behavior. *American Journal of Sociology*, 83(6), 1420–1443.
- Greif, A. (1998). Historical and comparative institutional analysis. *American Economic Review*, 88(2), 80–84.
- Greif, A. (2006). *Institutions and the path to modern economy: Lessons from medieval trade*. New York: Cambridge University Press.
- Grossi, P. (1977). *Un altro modo di possedere. L'emersione di forme alternative di*

*proprietà alla coscienza giuridica postunitaria*. Milano: Giuffrè.

- Grossi, P. (1981). *An alternative to private property*. London: University of Chicago Press.
- Grossi, P. (1990). Assolutismo giuridico e proprietà collettive. *Quaderni Fiorentini per la Storia del Pensiero Giuridico Moderno*, 19, 504–555.
- Grove, M., Pearce, E., & Dunbar, R. I. M. (2012). Fission–fusion and the evolution of hominin social systems. *Journal of Human Evolution*, 62(2), 191–200.
- Gueresi, P., Martuzzi Veronesi, F., & Pettener, D. (1994). Aspetti biodemografici delle valli trentine l’alta Valle di Sole dal 1750 al 1923. *Bollettino di Demografia Storica*, 21, 79–102.
- Gueresi, P., Pettener, D., & Martuzzi Veronesi, F. (2001). Marriage behaviour in the Alpine Non Valley from 1825 to 1923. *Annals of Human Biology*, 28(2), 157–171.
- Guglielmino, C. R., De Silvestri, A., Martinetti, M., Daielli, C., Salvaneschi, L., & Cuccia, M. (1996). The genetic structure of a province as revealed by surnames and HLA genes: Potential utility in transplantation policy. *Annals of Human Genetics*, 60, 221–229.
- Habyarimana, J., Humphreys, M., Posner, D. N., Jeremy, M., & Weinstein, J. M. (2007). Why does ethnic diversity undermine public goods provision? *American Political Science Review*, 101(4), 709–725.
- Haddock, D. D., & Kiesling, L. (2002). The Black Death and property rights. *Journal of Legal Studies*, 31(S2), S545–S587.
- Halford, G. S., Baker, R., McCredden, J. E., Bain, J. D., & McCredden, J. E. (2005). How many variables can humans process? *Psychological Science*, 16(1), 70–76.

- Hammons, C. W. (1999). Was James Madison Wrong? Rethinking the American preference for constitutions. *American Political Science Review*, 93(4), 837–849.
- Hampl, J. S., & Hampl, W. S. (1997). Pellagra and the origin of a myth: Evidence from European literature and folklore. *Journal of the Royal Society of Medicine*, 90(11), 636–639.
- Hardin, G. (1968). The tragedy of the commons. *Science*, 162(3859), 1243–1248.
- Hardin, G. (1988, October 22). Commons failing. *New Scientist*, 76, 29.
- Hart, O., & Moore, J. (1988). Incomplete contracts and renegotiation. *Econometrica*, 56(4), 755–785.
- Heckathorn, D. D. (1993). Collective action and group heterogeneity: Voluntary provision versus selective incentives. *American Sociological Review*, 58(3), 329–350.
- Henrich, J., Boyd, R., Bowles, S., Camerer, C., Fehr, E., Gintis, H., ... Tracer D. (2005). "Economic man" in cross-cultural perspective: Behavioral experiments in 15 small-scale societies. *Behavioral and Brain Sciences*, 28(6), 795–815, 815–55.
- Henrich, J., Ensminger, J., McElreath, R., Barr, A., Barrett, C., Bolyanatz, A., ... Ziker, J. (2010). Markets, religion, community size, and the evolution of fairness and punishment. *Science*, 327(5972), 1480–4.
- Henrich, J., McElreath, R., Barr, A., Ensminger, J., Barrett, C., Bolyanatz, A., ... Ziker, J. (2006). Costly punishment across human societies. *Science*, 312(5781), 1767–70.
- Herrmann, B., Thöni, C., & Gächter, S. (2008). Antisocial punishment across societies. *Science*, 319(5868), 1362–7.

- Hill, R. A., Bentley, R. A., & Dunbar, R. I. M. (2008). Network scaling reveals consistent fractal pattern in hierarchical mammalian societies. *Biology Letters*, 4(6), 748–51.
- Hill, R. A., & Dunbar, R. I. M. (2003). Social network size in humans. *Human Nature*, 14(1), 53–72.
- Hirschman, A. O. (1964). The paternity of an index. *American Economic Review*, 54(5), 761.
- Hume, D. (1965). On morals. In L. Selby-Bigge (Ed.), *Treatise of human nature* (pp. 538). Oxford: Clarendon Press.
- Huntsman, A. G. (1944, June 30). Fishery depletion. *Science*, 99(2583), 534–535.
- Isaac, R. M., & Walker, J. M. (1994). Group size and the voluntary of public goods. Experimental provision evidence utilizing large groups. *Journal of Public Economics*, 54, 1–36.
- Jedin, H. (1981). *Storia del Concilio di Trento* (Volume 4). Brescia: Morcelliana.
- Jenkins, S. P. (2004). *Survival analysis*. (Unpublished manuscript). Institute for Social and Economic Research, University of Essex, Colchester.
- Jobling, M. A. (2001). In the name of the father: Surnames and genetics. *Trends in Genetics*, 17(6), 353–357.
- Johansson, S. R. (1988). The computer paradigm and the role of cultural information in social systems. *Historical Methods*, 21, 172–188.
- Johnson, G. A. (1983). Decision-making organization and pastoral nomad camp size. *Human Ecology*, 11(2), 175–199.
- Jowett, B. (1885). *The politics of Aristotle: Translated into English with introduction, marginal analysis, essays, notes and indices*. Oxford: Clarendon Press.
- Kandori, M. (1992). Social norms and community enforcement. *Review of Economic*

- Studies*, 59(1), 63–80.
- Kappenberger, G., & Kerkmann, J. (1997). *Il tempo in montagna: Manuale di meteorologia alpina*. Bologna: Zanichelli & AINEVA.
- King, T. E., & Jobling, M. A. (2009). What's in a name? Y chromosomes, surnames and the genetic genealogy revolution. *Trends in Genetics*, 25(8), 351–360.
- Knuth, D. (1998). Sorting by merging. In *Sorting and searching. The art of computer programming* (pp. 158–168). Reading, MA: Addison-Wesley.
- Komlos, J. (1989). *Nutrition and economic development in the eighteenth-century Habsburg Monarchy*. Princeton, NJ: Princeton University Press.
- Kosse, K. (1990). Group size and societal complexity: Thresholds in the long-term memory. *Journal of Anthropological Archaeology*, 9(3), 275–303.
- Kosse, K. (2001). Some regularities in human group formation and the evolution of societal complexity. *Complexity*, 6(1), 60–64.
- Kremer, M. (1993). Population growth and technological change: One million B.C. to 1990. *Quarterly Journal of Economics*, 108(3), 681–716.
- Kudo, H., & Dunbar, R. I. M. (2001). Neocortex size and social network size in primates. *Animal Behaviour*, 62(4), 711–722.
- La Porta, R., Lopez-de Silanes, F., Shleifer, A., & Vishny, R. (1999). The quality of government. *Journal of Law, Economics & Organization*, 15(1), 222–279.
- Lam, W. F. (1998). *Governing irrigation systems in Nepal: Institutions, infrastructure, and collective action*. Oakland, CA: ICS Press.
- Lasker, G. W. (1977). A coefficient of relationship by isonymy: A method for estimating the genetic relationship between populations. *Human Biology*, 49(3), 489–93.
- Latham, M. C. (1973). A historical perspective. In A. Berg, N. S. Scrimshaw, & D.

- Call (Eds.), *Nutrition, national development and planning* (pp. 313–328).  
Cambridge, MA: MIT University Press.
- Leeson, P. T. (2005). Endogenizing fractionalization. *Journal of Institutional Economics*, 1(1), 75–98.
- Lehmann, J., Korstjens, A. H., & Dunbar, R. I. M. (2007). Fission–fusion social systems as a strategy for coping with ecological constraints: A primate case. *Evolutionary Ecology*, 21, 613–634.
- Levenshtein, V. (1966). Binary codes capable of correcting deletions, insertions, and reversals. *Soviet Physics Doklady* (10), 707–10.
- Levine, R., & Easterly, W. (1997). Africa’s growth tragedy: Policies and ethnic divisions. *Quarterly Journal of Economics*, 112(4), 1203–1250.
- Libecap, G. D. (1989). *Contracting for property rights*. New York: Cambridge University Press.
- Libecap, G. D. (1995). The conditions for successful collective action. In R. O. Keohane & E. Ostrom (Eds.), *Local commons and global interdependence: Heterogeneity and cooperation in two domains* (pp. 161–190). London: Sage.
- Libecap, G. D. (2009). Open-access losses and delay in the assignment of property rights. *Arizona Law Review*, 50(2008), 379–408.
- Libecap, G. D., & Johnson, R. N. (1982). Contracting problems and regulation: The case of the fishery. *American Economic Review*, 72(5), 1005–1022.
- Libecap, G. D., & Wiggins, S. N. (1984). Contractual responses to the common pool: Prorating of crude oil production. *American Economic Review*, 74(1), 87–98.
- Machiavelli, N. (2003). *The art of war*. (C. Lynch, Trans.). Chicago: University of Chicago Press.

- Macy, M. W. (1991). Chains of cooperation: Threshold effects in collective action. *American Sociological Review*, 56(6), 730–747.
- Maine, H. S. (1861). *Ancient law: Its connection with the early history of society, and its relation to modern ideas*. London, UK: John Murray, Albemarle Street.
- Maine, H. S. (1875). *The effects of observation of India on modern European thought*. Rede Lecture, May 22, 1875. Cambridge, UK: University of Cambridge.
- Mangini, A., Spötl, C., & Verdes, P. (2005). Reconstruction of temperature in the Central Alps during the past 2000 yr from a delta(18)O stalagmite record. *Earth and Planetary Science Letters*, 235, 741–751.
- Marwell, G., Oliver, P. E., & Prahl, R. (1988). Social networks and collective action: A theory of critical mass. III. *American Journal of Sociology*, 94(3), 502–34.
- Mathieu, J., & Furter, R. (2007). Urban development in early modern Europe: The significance of altitude. «Petites villes en montagne, de l'Antiquité romaine au XXe siècle, Europe occidentale et centrale ». Colloque international, Clermont-Ferrand, 6–9 juin 2007.
- Mazzone, U. (2002). Trento: Città del concilio. Aspetti e momenti di uno storico appuntamento. In M. Bellabarba & G. Olmi (Eds.), *Storia del Trentino -IV - L'età moderna* (pp. 465–504). Bologna: Il Mulino, Istituto Trentino di Cultura.
- Mccarty, C., Killworth, P. D., Bernard, H. R., Johnsen, E. C., & Shelley, G. A. (2001). Comparing two methods for estimating network size. *Human Organization*, 60(1), 28–39.
- McCloskey, D. N. (1972). The enclosure of open fields: Preface to a study of its impact on the efficiency of English agriculture in the eighteenth century. *Journal of Economic History*, 32(1), 15–35.
- McKean, M. (1984). *Management of traditional common lands in Japan*. Duke



- University, Dept. of Political Science, mimeo.
- Miller, G. A. (1955). The magical number seven, plus or minus two: Some limits on our capacity for processing information. *Psychological Review*, *101*(2), 343–352.
- Miltenburg, N. V., Buskens, V., & Barrera, D. (2012). *Implementing punishment and reward in the public goods game: The effect of individual and collective decision rules*. (Unpublished manuscript). Utrecht University, Utrecht.
- Montalvo, J. G., & Reynal-Querol, M. (2003). Religious polarization and economic development. *Economics Letters*, *80*, 201–210.
- Motta, L. (1978). *Aspetti di storia economica e demografica di una valle del Trentino: La Valle del Fersina*. (Unpublished laurea thesis). University of Bologna, Bologna.
- Mullainathan, S. (2002). A memory-based model of bounded rationality. *Quarterly Journal of Economics*, *117*(3), 735–774.
- Mundlak, Y. (2005). Economic growth: Lessons from two centuries of American agriculture. *Journal of Economic Literature*, *43*(4), 989–1024.
- Myerson, R. (1997). *Game theory: Analysis of conflict*. Cambridge, MA: Harvard University Press.
- Nagendra, H. (2011). *Heterogeneity and collective action for forest management*. United Nations Development Programme, Human Development Reports, Research Paper 2011/02.
- Naidu, S. C. (2005). *Heterogeneity and common pool resources: Collective management of forests in Himachal Pradesh, India*. University of Massachusetts, Amherst Resource Economics Working Paper No. 2005-8.
- Naroll, R. (1956). A preliminary index of social development. *American Anthro-*

*pologist*, 58(4), 687–715.

- Negretto, G. L. (2012). Replacing and amending constitutions: The logic of constitutional change in Latin America. *Law & Society Review*, 46(4), 749–779.
- Nequirito, M. (2002). *A norma di Regola: Le comunità di villaggio trentine dal medioevo fino alla fine del '700*. Trento: Soprintendenza per i beni librari e archivistici Provincia Autonoma di Trento.
- Nequirito, M. (2004). *L'epoca d'ogni cambiamento: Storia e documenti trentini del periodo napoleonico*. Trento: Soprintendenza per i beni librari e archivistici Provincia Autonoma di Trento.
- Netting, R. M. (1972). Of men and meadows: Strategies of Alpine land use. *Anthropological Quarterly*, 45(3), 132–144.
- Netting, R. M. (1981). *Balancing on an Alp: Ecological change and continuity in a Swiss mountain community*. Cambridge, UK: Cambridge University Press.
- North, D. C. (1990). *Institutions, institutional change and economic performance*. Cambridge: Cambridge University Press.
- North, D. C., & Thomas, R. P. (1973). *The rise of the Western world: A new economic history*. Cambridge: Cambridge University Press.
- North, D. C., & Weingast, B. R. (2006). *A conceptual framework for interpreting recorded human history*. NBER Working Paper No. 12795.
- Nubola, C. (2002). Istituzioni ecclesiastiche e vita religiosa nell'età dei Cles e dei Madruzzo. In M. Bellabarba & G. Olmi (Eds.), *Storia del Trentino -IV -L'età moderna* (pp. 423–464). Bologna: Il Mulino, Istituto Trentino di Cultura.
- Nugent, J. B., & Sanchez, N. (1998). Common property rights as an endogenous response to risk. *American Journal of Agricultural Economics*, 80(3), 651–657.

- Oliver, P., & Marwell, G. (1988). The paradox of group size in collective action: A theory of the critical mass. II. *American Sociological Review*, 53(1), 1–8.
- Oliver, P., Marwell, G., & Teixeira, R. (1985). A theory of the critical mass. I. Group heterogeneity, interdependence, and the production of collective action. *American Journal of Sociology*, 91(3), 522–556.
- Oliver, P. M. (1993). Formal models of collective action. *Annual Review of Sociology*, 19(1), 271–300.
- Olsen, J. P. (1997). Institutional design in democratic contexts. *Journal of Political Philosophy*, 5(3), 203–229.
- Olson, M. (1965). *The logic of collective action: Public goods and the theory of groups*. Cambridge, MA: Harvard University Press.
- Ostrom, E. (1990). *Governing the commons*. Cambridge, MA: Cambridge University Press.
- Ostrom, E. (2003). How types of goods and property rights jointly affect collective action. *Journal of Theoretical Politics*, 15(3), 239–270.
- Ostrom, E. (2005a). *Understanding institutional diversity*. Princeton: Princeton University Press.
- Ostrom, E. (2005b). Understanding the diversity of structured human interactions. In E. Ostrom (Ed.), *Understanding institutional diversity* (pp. 3–31). Princeton, NJ: Princeton University Press.
- Ostrom, E. (2009a). Design principles of robust property-rights institutions: What have we learned? In K. G. Ingram & H. Yu-Hung (Eds.), *Property rights and land policies* (pp. 25–51). Cambridge, MA: Lincoln Institute of Land Policy.
- Ostrom, E. (2009b). Engaging impossibilities and possibilities. In K. Basu & R. Kanbur (Eds.), *Arguments for a better world: Essays in honor of Amartya Sen*

- (pp. 522–541). New York: Oxford University Press.
- Ostrom, E., Burger, J., Field, C. B., Norgaard, R. B., & Policansky, D. (1999). Revisiting the commons: Local lessons, global challenges. *Science*, 284, 278–282.
- Ostrom, E., Gardner, R., & Walker, J. (1994). *Rules, games, and common-pool resources*. Ann Arbor: University of Michigan Press.
- Ostrom, E., & Hess, C. (2007). *Private and common property rights*. (Unpublished manuscript). Available at SSRN: <http://ssrn.com/abstract=1304699>.
- Ostrom, E., & Walker, J. (1989). *Communication in a commons: Cooperation without external enforcement*. (Unpublished manuscript). Workshop in Political Theory and Policy Analysis, Indiana University, Bloomington.
- Ostrom, E., Walker, J., & Gardner, R. O. Y. (1992). Covenants with and without a sword: Self-governance is possible. *American Political Science Review*, 86(2), 404–417.
- Papke, L. E., & Wooldridge, J. M. (1996). Econometric methods for fractional response variables with an application to 401 (K) plan participation rates. *Journal of Applied Econometrics*, 11(6), 619–632.
- Pearson, C. J., & Ison, R. L. (1997). *Agronomy of grassland systems*. Cambridge (UK): Cambridge University Press.
- Pedersen, E. J., Kurzban, R., & McCullough, M. E. (2013). Do humans really punish altruistically? A closer look. *Proceeding of the Royal Society of Sciences B*, 280(March), 20122723.
- Perini, A. (1852). *Statistica del Trentino -Vol. II*. Trento: Tipografia fratelli Perini.
- Piva, J. (1981). *Ambiente economico-sociale e movimento demografico a Pergine nella seconda metà del settecento*. (Unpublished laurea thesis). University of

Padova, Padua.

- Platteau, J.-P., & Baland, J.-M. (1998). Division of the commons: A partial assessment of the new institutional economics of land rights. *American Journal of Agricultural Economics*, 80(3), 644–650.
- Popkin, S. L. (1979). *The rational peasant: The political economy of rural society in Vietnam*. Berkeley, CA: University of California Press.
- Poteete, A. R., Janssen, M. A., & Ostrom, E. (2010). *Working together: Collective action, the commons and multiple methods in practice*. Princeton: Princeton University Press.
- Poteete, A. R., & Ostrom, E. (2004). Heterogeneity, group size and collective action: The role of institutions in forest management. *Development and Change*, 35(Sbr 9521918), 435–461.
- Powell, J., Lewis, P. A., Roberts, N., García-Fiñana, M., & Dunbar, R. I. M. (2012). Orbital prefrontal cortex volume predicts social network size: An imaging study of individual differences in humans. *Proceeding of the Royal Society of Sciences B*, 279(1736), 2157–2162.
- Prost, M., Boëtsch, G., Girotti, M., & Rabino-Massa, E. (2008). Surname analysis in biological anthropology: Alpine populations in the 17th and 18th centuries. *Human Biology*, 80(4), 377–391.
- Provincia Autonoma di Trento (2011). *Inventario dei fondi archivistici*. Retrieved from [http://www.trentinocultura.net/catalogo/cat\\_fondi\\_arch/cat\\_inventari\\_h.asp](http://www.trentinocultura.net/catalogo/cat_fondi_arch/cat_inventari_h.asp)
- Putnam, R. D. (1993). *Making democracy work: Civic traditions in modern Italy*. Princeton, NJ: Princeton University Press.
- Ray, B., & Bhattacharya, R. (2011). Transaction costs, collective action and survival

- of heterogeneous co-management institutions: Case study of forest management organisations in West Bengal, India. *Journal of Development Studies*, 47(2), 253–273.
- Ray, P. (1973). Independence of irrelevant alternatives. *Econometrica*, 41(5), 987–991.
- Riccadonna, G. (1990). *Statuti della città di Arco*. Arco (TN): Comune di Arco.
- Roberts, S. G., Wilson, R., Pawel, F., & Dunbar, R. I. M. (2008). Individual differences and personal social network size and structure. *Personality and Individual Differences*, 44(4), 954–964.
- Robinson, J. A. (2013). Measuring institutions in the Trobriand Islands: A comment on Voigt's paper. *Journal of Institutional Economics*, 9(1), 27–29.
- Rockenbach, B., & Milinski, M. (2006). The efficient interaction of indirect reciprocity and costly punishment. *Nature*, 444(7120), 718–23.
- Saaksvuori, L., Mappes, T., Puurtinen, M., & Sa, L. (2011). Costly punishment prevails in intergroup conflict. *Proceeding of the Royal Society of Sciences B*, 278(March), 3428–3436.
- Sabbatini, R. (2002). Manifatture e commercio. In M. Bellabarba & G. Olmi (Eds.), *Storia del Trentino -IV -L'età moderna* (pp. 283–318). Bologna: Il Mulino, Istituto Trentino di Cultura.
- Sartori Montecroce, T. (2002). *La Comunità di Fiemme e il suo diritto statuario*. Cavalese, Trento.
- Schaefer, M. B. (1956). Some aspects of the dynamics of populations important to the management of the commercial marine fisheries. *Bulletin of the Inter-American Tropical Tuna Commission*, 1(2), 27–56.
- Schlager, E., & Ostrom, E. (1991). Property rights regimens and natural resources: A

- conceptual analysis. *Land Economics*, 68(3), 249–262.
- Seabright, P. (1996). Accountability and decentralisation in government: An incomplete contracts model. *European Economic Review*, 40, 61–89.
- Sella, G., Marin, A., Santovito, A., Girotti, M., Cervella, P., & Delperio, M. (2010). Demographic structure and microevolution of an Italian alpine isolated population. *Genetika*, 46(8), 1132–8.
- Seneca, F. (1953). Problemi economici e demografici del Trentino nei secoli 13 e 14. In Comitato Economico-Scientifico Trentino (Ed.), *Studi e Ricerche Storiche sulla Regione Trentina*. Padova: Stediv.
- Shepsle, K. A. (1989). Studying institutions: Some lessons from the rational choice approach. *Journal of Theoretical Politics*, 1(2), 131–147.
- Shepsle, K. A. (2010). *Analyzing politics: Rationality, behavior, and institutions* (2nd ed.). New York: W. W. Norton & Company.
- Shirley, M. M. (2013). Measuring institutions: How to be precise though vague. *Journal of Institutional Economics*, 9(1), 31–33.
- Siegel, D. (2009). Social networks and collective action. *American Journal of Political Science*, 53(1), 122–138.
- Siegel, S. (1956). *Non-parametric statistics for the behavioral sciences*. New York: McGraw Hill.
- Sigmund, K., De Silva, H., Traulsen, A., & Hauert, C. (2010). Social learning promotes institutions for governing the commons. *Nature*, 466(7308), 861–863.
- Smith, A. (2011). Group composition and conditional cooperation. *Journal of Socio-Economics*, 40(5), 616–622.
- Smith, H. E. (2000). Semi-common property rights and scattering in the open fields.

- Journal of Legal Studies*, 29(1), 131–169.
- Smith, H. E. (2002). Exclusion versus governance: Two strategies for delineating property rights. *Journal of Legal Studies*, 31(S2), S453–S487.
- Smuts, B., Cheney, D. L., Seyfarth, R. M., Wrangham, R. W., & Struhsaker, T. T. (1987). *Primate societies*. London: University of Chicago Press.
- Sparapani, L. (1989). I libri parrocchiali della diocesi di Trento. In G. Coppola & C. Grandi (Eds.), *La conta delle anime. Popolazione e registri parrocchiali. Questioni di metodo ed esperienze. Atti del convegno, Trento, 26-27 ottobre 1987* (pp. 217–319). Bologna: Il Mulino.
- Stavins, R. N. (2011). The problem of the commons: Still unsettled after 100 years. *American Economic Review*, 101(February), 81–108.
- Stella, A. (1958). *Politica ed economia nel territorio trentino-tirolese dal XIII al XVII secolo*. Padova: Antenore.
- Stenico, R. (1999). *Notai che operarono nel Trentino dall'anno 845*. Trento: Biblioteca San Bernardino.
- Stephan, H., Frahm, H., & Baron, G. (1981). New and revised data on volumes of brain structures in insectivores and primates. *Folia Primatologica*, 35(1), 1–29.
- Stevenson, G. G. (1991). *Common property economics: A general theory and land use applications*. Cambridge, UK: Cambridge University Press.
- Stiller, J., & Dunbar, R. I. M. (2007). Perspective-taking and memory capacity predict social network size. *Social Networks*, 29(1), 93–104.
- Tardivo, F. (2005). *Brentonico nel Medioevo. Istituzioni, società, beni culturali*. (Unpublished laurea thesis). University of Bologna, Bologna.
- Thapa, M. B. (1995). *Indigenous institutions and pasture managements in high*



- altitude Nepal*. (Unpublished Manuscript). Workshop in Political Theory and Policy Analysis, Indiana University, Bloomington.
- Tiebout, C. M. (1956). A pure theory of local expenditures. *Journal of Political Economy*, 64(5), 416–424.
- Tirole, J. (1999). Incomplete contracts: Where do we stand? *Econometrica*, 67(4), 741–781.
- Tovazzi, G. (1986). *Malographia Tridentina: Cronaca dei fatti calamitosi avvenuti nel Trentino e regioni adiacenti dai primi anni d.C. al 1803*. Trento: Lions Club.
- Ugander, J., Karrer, B., Backstrom, L., & Marlow, C. (2011). The anatomy of the Facebook social graph. arXiv:1111.4503v1 [cs.SI].
- Varanini, G. M. (2004). L'economia. Aspetti e problemi (XIII-XV secolo). In A. Castagnetti & G. M. Varanini (Eds.), *Storia del Trentino -III -L'età medievale* (pp. 461–515). Bologna: Il Mulino, Istituto Trentino di Cultura.
- Varesco, G. (1981). *Ambiente economico-sociale e movimento demografico a Predazzo nella seconda metà del Settecento*. (Unpublished laurea thesis). University of Padova, Padua.
- Varughese, G., & Ostrom, E. (2001). The contested role of heterogeneity in collective action: Some evidence from community forestry in Nepal. *World Development*, 29(5), 747–765.
- Vedeld, T. (2000). Village politics: Heterogeneity, leadership and collective action. *Journal of Development Studies*, 36(5), 105–134.
- Viazzo, P. P. (2006). *Upland communities: Environment, population and social structure in the Alps since the sixteenth century (Cambridge studies in population, economy and society in past time)*. Cambridge, UK: Cambridge

University Press.

Vigdor, J. L. (2004). Community composition and collective action: Analyzing initial mail response to the 2000 census. *Review of Economics and Statistics*,

86(February), 303–312.

Voigt, S. (2013a). How (not) to measure institutions. *Journal of Institutional Economics*, 9(1), 1–26.

Voigt, S. (2013b). How (not) to measure institutions: A reply to Robinson and Shirley. *Journal of Institutional Economics*, 9(1), 35–37.

Wade, R. (1988). *Village republics: Economic conditions for collective action in South India (Cambridge South Asian Studies)*. Cambridge, UK: Cambridge University Press.

Watson, H. W., & Galton, F. (1875). On the probability of the extinction of families.

*Journal of the Anthropological Institute of Great Britain and Ireland*, 4(1875), 138–144.

Watts, D. J., & Strogatz, S. (1998). Collective dynamics of “small-world” networks.

*Nature*, 393(6684), 440–442.

Williamson, O. E. (1967). Hierarchical control and optimum firm size. *Journal of Political Economy*, 75(2), 123–138.

Williamson, O. E. (1979). Transaction-cost economics: The governance of contractual relations. *Journal of Law and Economics*, 22(2), 233–261.

Williamson, O. E. (1981). The economics of organization: The transaction cost approach. *American Journal of Sociology*, 87(3), 548–577.

Williamson, O. E. (1986). *Economic organization: Firms, markets, and policy control*. Brighton: Wheatsheaf.

Wooldridge, J. M. (2003). *Introductory econometrics: A modern approach* (3rd ed.).

Mason, OH: South-Western Cengage Learning.

Wopfner, H. (1954), *Bergbauernbuch Innsbruck*, Vol. II, Tyrolia.

Wu, J.-j., Zhang, B.-y., Zhou, Z.-x., He, Q.-q., Zheng, X.-d., Cressman, R., & Tao, Y. (2009). Costly punishment does not always increase cooperation. *Proceedings of the National Academy of Sciences of the United States of America*, 106(41), 17448–17451.

Zhou, W., Sornette, D., Hill, R. A., & Dunbar, R. I. M. (2005). Discrete hierarchical organization of social group sizes. *Proceeding of the Royal Society of Sciences B*, 272(April 2004), 439–444.

## APPENDIX A: DEFINITION OF TERMS

**Allocation of property rights.** The allocation of property rights is interpreted as a welfare maximization problem. “Every distribution of property rights has with it a set of production costs and a set of transaction costs. The distribution of property rights that maximizes the gains from trade net of all costs is the optimal distribution” (Allen, 2000). In addition, the determination of group size in institutions may be led by factors related to production costs (extraction of the resource) and factors related to transaction costs (Allen, 2000; Allen & Lueck, 2002).

**Appropriation.** Appropriation is a type of collective action that consists in the process of direct extraction of resources by a group that is either coordinated by informal rules of cooperation (See: Informal Institution) or uncoordinated and, therefore, at risk of failure of collective action.

**Appropriators (effective).** The number of “effective” appropriators can be estimated only when a list of insiders is provided, and these lists are often available only when there is an assembly record in which it is possible to measure participation.

**Appropriators (potential).** The number of potential appropriators on the commons is measured using population estimates. Population size estimates include both insiders and outsiders in the appropriators’ group.

**Assembly roles.** The individuals in assemblies have a role. They can be divided in two classes: those having voting rights (active if they cast a vote, non-active if they are not voting) and those without voting rights (non-members) in the process of deliberation of the community charter. The attendees without voting rights were the notary, the witnesses, and other non-attending village members.

**Carte Di Regola.** Also *Carte* or “rural charters.” The *Carte* were private-order formal institutions with the main purpose of disciplining the use of the commons of each village community: forest and pastures. Each *Carta* established a community governance system based on face-to-face village assemblies (“*Regole*”) and had to be approved by the prince-bishop in Trento, appointed for a lifetime term jointly by the pope in Rome and the emperor of the Holy Roman Empire. The prince-bishop had both secular and religious authority in the region from 1027 until 1803 and decentralized the economic governance of the villages retaining jurisdiction over tax and criminal matters.

**Collective action.** In economic theory, collective action is defined as the provision of public goods and other collective goods through the collaboration of two or more individuals. One of the concerns of studies of collective action is the impact of externalities on group behavior. See Olson (1965). Yoram Barzel

(2002) defines collective action as “simultaneous actions by a number of individuals” (p.114). Collective action is required when a group of individuals sharing a common interest wishes to reach an agreement on a particular course of action by discussing and then implementing the decision undertaken by the group.

**Collective action in the commons.** See: Appropriation.

**Collective action in institutions.** See: Participation.

**Common-pool resources.** Common-pool resources are distinguished from pure public goods because of the way they can be appropriated. Their size or natural characteristics allow the costly exclusion of potential users from attaining benefits from their use. Examples of common-pool resources include irrigation systems, fisheries, pastures, forests, water basins, or the atmosphere.

**Common property.** Stevenson (1991) defines: “Common property [as] a form of resource ownership with the following characteristics: 1) the resource unit has bounds that are well defined by physical, biological and social parameters; 2) there is a well delineated group of users, who are distinct from persons excluded from resource use; 3) multiple included users participate in resource extraction; 5) users share joint, non-exclusive entitlement to the in situ or fugitive resource prior to its capture or use; 6) users compete for the resource, and thereby impose negative externalities on one another; 7) a well-delineated group of right holders exists, which may or may not coincide with the group of users” (p. 40).

**Commons.** See: Common-pool Resources.

**Community governance rules.** Rules decided by the assembly to govern the community and not aimed directly to the management of the collective action on resources. They are divided in three classes: governance rules, participation rules, and constraints on outsiders.

**Community.** When not specified otherwise, the community is the unit of observation. Communities are composed of one or more villages or subgroups of villages called clusters or subgroups.

**Complete *Carte*.** Complete charters are stand-alone documents that lay down the rules for governing the economic resources of a community; they can be first adoptions or later renewals of previous charters. Some communities may have no charter, while others may have adopted up to seven complete charters in the period studied.

**Complexity of institutions.** Two indexes of institutional complexity are constructed. The length of the document decided by the assembly and the number of assembly roles provide a measure of the complexity of formal institutions.

**Constraints on outsiders.** Constraints on outsiders are community governance rules that described the behavior of the community toward the non-members (foreigners). Generally, these rules imposed limitations to the action of outsiders, who were excluded from assembly participation. Therefore, this exclusion also entailed the impossibility of being an active part in the rule-making process.

**Content of rules (formal institutions).** The content of the rules decided by the assembly is the written outcome of the institutional process, decided by the community members. Therefore, the content of the rules, in particular if they are community governance rules or resource management rules, is an important measure that can correlate with both social heterogeneity and resource heterogeneity.

**Content of the *Carte*.** The normative content of the charters contains community governance rules and resource management rules.

**Economic property rights.** See: Property rights.

**Exogenous population growth.** In the process of institutional change, population growth is assumed to be exogenously determined. This assumption allows the consideration of changes in population as independent from the institutional type and organization changes. As a consequence, institutions and organizations adapt to increasing or decreasing population growth: in particular, groups with larger initial population are deemed to have faster technological change and population growth (Kremer, 1993).

**Fission and fusion.** Fission and fusion are decisions undertaken by the group to sustain collective action in the commons, under both the informal and the formal institutional regimes; the prediction is that when the group overcomes the critical size threshold, it will divide into one or more independent groups (fission); alternatively, if two or more groups are too small to sustain collective action, they may merge in a larger entity (fusion).

**Fission clustering and coexistence.** Fission clustering and coexistence are weak fission events. They are defined as institutional changes occurring after (or in conjunction with) fission clustering: within a cluster, one or more villages may decide to have a village charter coexisting with the cluster charter and the multi-village charter (if any).

**Fission clustering.** Fission clustering is a strong fission event. It occurs when the multi-village structures interaction by letting each village organize independently in clusters of one or more villages, which send to the multi-village assembly only the representatives of the village(s).

**Fission coexistence.** Fission coexistence is a weak fission event. It is defined as the adoption of a charter by one or more villages, which are not required to bargain

their independence from all the other villages or the multi-village organization, and they coexist with the multi-village charter.

**Fission independence.** Fission independence is a strong fission event (see: Fission). With the adoption of a charter, the villages separate their interaction from the multi-village organization and have an assembly independent from the multi-village one and from those of the other villages.

**Fission.** The fission behavior is the division of a community in two or more sub-groups. It has four alternative declinations: coexistence, clustering, clustering and coexistence, and independence. Fission events can be *strong* or *weak* in terms of the intensity, measured by transaction costs required for enforcement.

**Foreigners.** See: Outsiders.

**Formal institution.** A type of institution governed by formal rules of cooperation, overseeing a collective action of participation (see: Participation).

**Framework.** The framework formalizes the threshold hypothesis in a graphical form. It contains the following components: a) group b) group size threshold, c) the institutional type (informal or formal), d) two types of collective action (participation and appropriation), e) fission–fusion behavior (see Figure 1.1).

**Fusion.** Fusion is the merger of the villages in a multi-village organization. The fusion is oftentimes followed by a fission event, underlining a collective action problem.

**Governance (community).** The governance of the institution may be developed in one or more layers. The formal regulation of collective action in the rural charters shows evidence of fission and fusion of communities over time. In our case study, sometimes face-to-face interaction occurs in communities that are structured in two or more coordinating subgroups. Such communities are termed multi-layered. Multi-layered communities are distinguished from one-layered and cluster communities. The distinction between single-layered and multi-layered communities concerns the governance of communities.

**Governance rules.** Governance rules are community governance rules that describe the requirements and the duration of assembly roles and define the system of checks-and-balances necessary to elect and make accountable (and, occasionally, even liable) those who were called to lead the institution for collective action in the capacity of community officers.

**Group size threshold.** A group size threshold is a tipping point beyond which the group opts for a different institutional type to manage collective action.

**Group.** A group consists of a number of individuals who interact face-to-face, decide to cooperate, and collectively act toward the attainment of a common goal. The

number of potential appropriators on the commons is measured using population estimates. Population size estimates include both insiders and outsiders in the appropriators' group.

**Heterogeneity (effects).** Heterogeneity is seen as a factor that increases the costs of social contracting for the allocation of property rights, decreases the likelihood of social cooperation, and hinders the process of aggregation of individual preferences in the provision of public goods.

**Heterogeneity.** As a first approximation, group heterogeneity can be defined as referring to existing differences across the group's observation units.

**Individual adoption.** See: Transition to a formal regime. Individual adoption is the transition of a village from an informal regime to a formal institution. This change is the initial status from which further changes of a multi-village are considered. It is assumed that once a community adopts a charter, the charter is enforced until 1800: that is, there is no switchback to the informal status.

**Informal institution.** A type of institution governed by informal rules of cooperation, overseeing a collective action of appropriation (see: Appropriation).

**Insiders.** Insiders are the legal community members: individuals who belong to the effective appropriators' group (*vicini*).

**Institutional design.** The design of formal institutions crafted by the group is defined by a set of institutional features. These features are deemed to represent the inner functioning of the formal institution and are as follows: rule content, rule balance, levels of complexity, the consensus within the group in reaching the collective decision, and stability over time of these decisions. Factors that are deemed to influence the design of the formal institution, and ultimately the collective action in the commons, are as follows: the level of social cohesion, resource diversity, and group size. Institutional design can be defined as a "process aimed at producing prescriptions, organization charts and plans, usually with some adaptive rules for coping with unforeseen circumstances" (Olsen, 1997). It can be reduced to a number of key institutional features considering the normative content of the new institution in terms of structure and content.

**Legal property rights.** See: Property rights.

**Length of the document (formal institutions).** The length of the document consists in the count of the number of rules contained in a document. The length may be related to the choice of the assembly of writing a complete social contract or leaving some gaps.

**Members.** See: Insiders.



**Modifications.** Modifications are partial amendments to charters that occurred after the adoption of a complete charter that take the form of additions or appendices to the pre-existing document.

**Multi-layered (community).** In a multi-layered community, at least one of the two criteria does not hold: either there are separate assemblies by village or subgroup or there is a partitioning of the common resources for use by village or subgroup or both. A multi-layered community may include two or more bordering villages, or it may consist in a multi-village organization or a cluster of more villages. In that case, the general assembly may still include all members or only selected representatives from each village or a subgroup of members.

**Multi-village.** Communities comprising more than one village. They can be single-layered or multi-layered.

**Non-members.** Individuals who attended the assembly as officers but did not have the right to cast a vote; these include notaries, witnesses, and outsiders in general. See: Outsiders.

**Number of roles (formal institutions).** The number of roles in the assembly may be a useful indicator for the degree of government specialization required to govern the community.

**Organization (community).** Observing a multi-village organization normally entails the adoption of a *Carta di Regola* and therefore the setting up of a formal institution that may govern more than one village.

**Other documents.** The number of potential appropriators on the commons is measured using population estimates. Population size estimates include both insiders and outsiders in the appropriators' group.

**Outsiders.** Outsiders (*forestieri*) are non-members; therefore, they are not legally entitled to access, use, or manage the common resources.

**Partial assembly.** In partial assemblies, only village representatives participate to the face-to-face collective action. Partial assemblies are distinguished from plenary assemblies (see).

**Participation rules.** Participation rules are community governance rules that described the requirements, the periodicity, and the modes of participation to legislative assemblies of community members.

**Participation.** Participation is a type of collective action that consists in a process of indirect appropriation of resources, mediated by rules of cooperation crafted and enforced by the group (formal institution).

**Plenary assembly.** Plenary assembly is defined here as a group size estimate that represents the largest face-to-face group of interactants, even when collective action is structured in more than one level. Plenary assemblies are distinguished from partial assemblies (see).

**Population.** Population estimates include both the insider and the outsider groups and provide a figure of the potential number of appropriators interacting in the commons.

**Quorum.** Quorum is defined as the number of active members in the community assembly required for the meeting to be validly constituted and to deliberate the collective decision.

**Resource fractionalization.** One intuitive way to study resource heterogeneity is to use a fractionalization index referring to classes of land resources. The index measures the probability that two hectares randomly drawn from the pool of hectares of a community belong to different resource classes.

**Resource heterogeneity.** Resource heterogeneity is measured as the diversity of resource endowments within a community.

**Resource management rules.** These rules defined the precise actions and precautions that had (or had not) to be undertaken by village members in order to coordinate in the access and the use of natural resources, mainly the commons (forest and pasture). The violation of each rule was normally backed by a monetary sanction (Casari, 2007), comprising at least the restoration of the damage and often a component to deter future damages.

**Single-layered (community).** Or: One-layer community. Single-layered communities can be ruled under either an informal or a formal regime, while multi-layered communities require by necessity a formal institution. In a single-layered community, active members met only in a general assembly (or interacted informally, if the single-layered community did not have a formal regime), and all members had access to all of the common resources according to the assembly regulations.

**Social heterogeneity.** Social heterogeneity is measured by the diversity of surnames in the group of the attendants to the assemblies.

**Stability (formal institutions).** In the present study, an institution is more stable than another when its forward duration is higher than that of the other.

**Stand-alone (villages).** Stand-alone villages never belong to a multi-village during their existence and are considered one-layer structure communities by default. They are considered as a control group in our analyses of the effects of fission and fusion in multi-village organization.

**Surname fractionalization.** Surname fractionalization is computed as the probability that two randomly selected people from a population are from different surname groups (families).

**Threshold hypothesis.** This is the conjecture tested in Chapters 5 and 6. Institutions for the management of the commons having the requirements listed by Ostrom (1990) transit from informal to formal institutions when they overcome the group size threshold; this threshold is within Dunbar's range; after crossing the threshold, large groups tend to structure their internal organization in smaller sub-groups. The thesis of this dissertation is that there exists a critical group size threshold that drives institutional change.

**Tragedy of the commons.** The tragedy of the commons is a collective action problem involving common-pool resources, identified by Hardin (1968). When multiple non-cooperating individuals have simultaneous access to a common resource, standard economic theory predicts that the resource becomes depleted, because individuals acting self-interestedly are compelled to extract the most individual benefit they can from the resource by bearing only a fraction of the total cost, despite the knowledge that doing so is contrary to the long-term interests of both the individuals and the group. Elinor Ostrom (1990) challenged this conventional theory by demonstrating that groups are able to overcome the tragedy of the commons by setting up institutions for collective action in which co-users of a common-pool resource coordinate extraction efforts and cooperate over the long run on a sustainable use of their common resources.

**Transaction costs.** The costs associated with the transfer, capture, and protection of rights (Barzel, 1997, 1982; Allen, 1991). Barzel (1997) states that "what Jensen and Meckling (1976) define as agency cost is what is defined here as transaction cost" (footnote 4, p. 4), and "when transaction costs are positive, rights to assets will not be perfectly delineated. The reason is that, relative to their value, some of the attributes of the assets are costly to measure" (p. 4). Transaction costs include: search and information costs, bargaining and decision costs, policing and enforcement costs (Dahlman, 1979).

**Transition to a formal institution.** An institutional change that entails an activity or a set of activities as a result of a group decision. After undertaking the decision, a group that was formerly governed by an informal institution adopts a formal institution, as, for example, a *Carta di Regola* (see: *Carta di Regola*).

**Type of institution.** The degree of formality of an institution. There can be informal and formal institutions for collective action in the commons.

**Village.** A village may include one or more cadastral units according to the 1897 land registers.

## APPENDIX B: INITIAL RESULTS

### B.1 Introduction

The purpose of this appendix is to replicate the results obtained by Casari (2007), in which the author writes:

“This article finds, in particular, that the likelihood of a legal institution’s being established increases with a community’s size, its proximity to other settlements, and the amount of its common resources.”

In the analysis of the case performed throughout the chapters in the dissertation—and particularly in Chapter 5—the focus was on finding possible explanations for the role of group size, and transaction costs appear to be one of the explanations having the highest explanatory power. Scholarly work supports this hypothesis implicitly, although this relation has not yet been formalized. In empirical analyses, the present author elaborated a strategy to identify the role of transaction costs and their possible relation with group size. Static and dynamic econometric analyses were performed, considering a variety of explanatory variables for the choice between informal and formal regimes, exploiting a rich dataset from archival sources covering the Principdom of Trento from 1200 until 1800 (described in Chapter 3).

The results in the econometric analyses performed in this appendix converge in underlining the relevance of group size in transitions between informal and formal allocation of property rights. One explanation is that there is a relation between group size and transaction costs and that transaction costs may be context dependent. Nevertheless, this relation is unclear, and the direction of causality cannot be determined clearly from the data.

This appendix focuses only on the replication of results using expanded datasets, which basically consists of adding new variables to fairly analogous regression models. Since the purpose of this appendix is not to be additive of original research, the reader may refer to the original article for a description and a discussion of the results. The main conclusion of this appendix is that the results obtained are in line with Casari (2007) with the additional data acquired.

In Subsection B.2, the reader will find a succinct description of the methodologies adopted to analyze the data. Section B.3 addresses the reader to a summary of the regression tables with standardized coefficients and the coefficients for population size in bold.

### B.2 Methods

Statistical analyses were performed on two separate datasets described in Chapter 3: the expanded panel and the reduced panel. The purpose of using two different datasets

was dictated by the necessity of observing communities in some selected years without time effects. The evolution of institutional choice over time was also considered. For this, two types of analyses, a static model (Subsection B.2.1) and a dynamic model (Subsection B.2.2), were developed.

To capture the impact of group size in the adoption of a formal regime, it was assumed that there are different information cost structures in different resource settings. As communities were endowed mainly with common land, they were divided into three classes according to the prevalence of a particular commons resource (pasture-prevalent, forest-prevalent, and mixed resources). The rationale behind this assumption is that collecting and disseminating information in the forest is more costly than in pasture-prevalent environments (monitoring at eyesight is easier in pastureland). Moreover, the risk of the tragedy is worse in forest-prevalent areas: they could be subjected to socially undesirable extraction with a low probability of being caught, particularly during nighttime, and forest has a renewal rate lower than a pastureland. This technique is helpful to infer the effects of transaction costs in two different environments. The simultaneous impact of several factors was tested on a) the probability of having a formal institution in each of the selected years, b) the risk of adopting a formal institution throughout the period 1200–1800.

Two logit models were used with a dummy that gives 1 when the community adopts a charter (formal interaction technology) and 0 otherwise (informal) as the dependent variable. Commons considered were forest and pastureland. Pastureland is composed of grazing land, alp, and half of the surface devoted to meadows (the other half is considered under an open-field regime and it is disregarded). Cultivated land is composed of vineyard, plow land, and fruit garden.

### **B.2.1. Static model**

In the static model, the determinants of the probability for a community to have a charter in a given year are sought. Let the likelihood for a community  $i$  of having a charter be defined by the following binary choice model using a logit regression:

$$\text{logit}(p_i) = \log \left( \frac{p_i}{1-p_i} \right) = \beta_0 + \beta_1 x_1 + \dots + \beta_k x_{k,i} + \varepsilon_i,$$

Where  $p_i$  is the probability for each community  $i$  to have a charter in one of the selected years. The error term  $\varepsilon$  is normally distributed. The following specifications are included in this static model: population size estimate, temperature estimate (Celsius), common land surface above the median (dummy), distance from the closest local town (Km), altitude difference from local town (mts.), forest v. pasture, commons v. cultivated land, and a set of 15 geographical controls (dummies). Summary statistics for the end period (1800) are reported in Table B.1 (Appendix D).

It was investigated whether the transaction cost structure is different in communities having two different types of resources (with two different production functions and two different monitoring costs). The same regression model was run for each of the six selected years and produced three panels: one considers all the observations regardless of the focus on a particular type of resource, and then separate estimates are provided for pasture-prevalent and forest-prevalent. Results of the empirical analyses are summarized in the regression tables: Table B.2 (Appendix D), Table B.3 (Appendix D), and Table B.4 (Appendix D). A logistic regression model was used, with robust unclustered standard errors. A set of 15 area dummy variables was inserted to control for geographical variation. The original coefficients were standardized to allow the reader to quickly compare the intensity of the effect of the regressors on the dependent variable directly from the table. The coefficients are expressed in terms of “1 standard deviation increase” and not in terms of effects of unit increases of each regressor on the dependent variable.

### B.2.2. Dynamic model

In the dynamic model, the focus is on the determinants of the change from informal to formal regimes during 1200–1800. It is, reasonably, assumed that the information network structure is different in pasture-prevalent and forest-prevalent areas. The model of institutional change employed in this part is similar to the one elaborated by Casari (2007). Some new specifications were added coming from the extension of the original dataset with further research. The statistical technique used was event history analysis (Allison, 1984; Jenkins, 2004), in which a number of predictors are tested to have impact or not on the likelihood of adoption of a first *Carta* over time. Another difference with respect to original analyses is that communities were differentiated by pasture or forest prevalence. The specification used is a logit model:

$$\text{logit}(p(t)_i) = \log\left(\frac{p(t)}{1-p(t)}\right) = \beta_0(t) + \beta_1 x_1 + \beta_2 x_2(t) + \varepsilon(t).$$

As in Casari (2007),  $P(t)$  represents the number of charters adopted in time interval  $t$  divided by the number of communities in the risk set in the same time interval  $t$ . The error term  $\varepsilon(t)$  is normally distributed. Communities in the residual group are not considered in the model. The model, widely applied in survival analysis (Allison, 1984; Jenkins, 2004), measures the increase or the decrease of the likelihood of adopting a charter for each community in the dataset in the discrete time interval  $[t, t-5]$ , captured by the last year of the observed interval. The dependent variable is a dummy that becomes 1 when the community adopts a charter and 0 otherwise. Each community is observed since the time of the first document and, in any case, as from the year 1200, and then disappears from the dataset when the dependent variable changes (i.e., until charter adoption). Three types of regressors were used: time trend, time invariant, and time varying. The time trend was captured with an entirely non-parametric hazard baseline using six century dummies (no dummy for 1800). Among

the time invariant regressors  $\beta_1 x_1$ , specifications for resource endowments (two ratios to control for the size of forests and for the size of commons: forest versus pasture, common land versus private land; additionally altitude and endowment of commons above the median [M=756.8 hectares in 1800] were also controlled for) and remoteness (in terms of linear distances in kilometers from the closest local town and in terms of altitude difference in meters from the closest local town) were inserted. Time varying regressors  $\beta_2 x_2(t)$  are population (estimate of each community in the last year of the considered time interval  $[t, t-5]$ ) to capture the effect of transaction costs (Cheung, 1969), climate (measured by a yearly temperature estimate for the community in the last year of the considered time interval), and dummies for specific historical events of regional scale and taxation-effects controls. Two dummy variables control the effect of taxation on charter adoption. The role of political influence is controlled using as a proxy the linear distance (in kilometers) from the closest local town (the political center approving the charters). Regression coefficients are reported in Table B.5 (Appendix D).

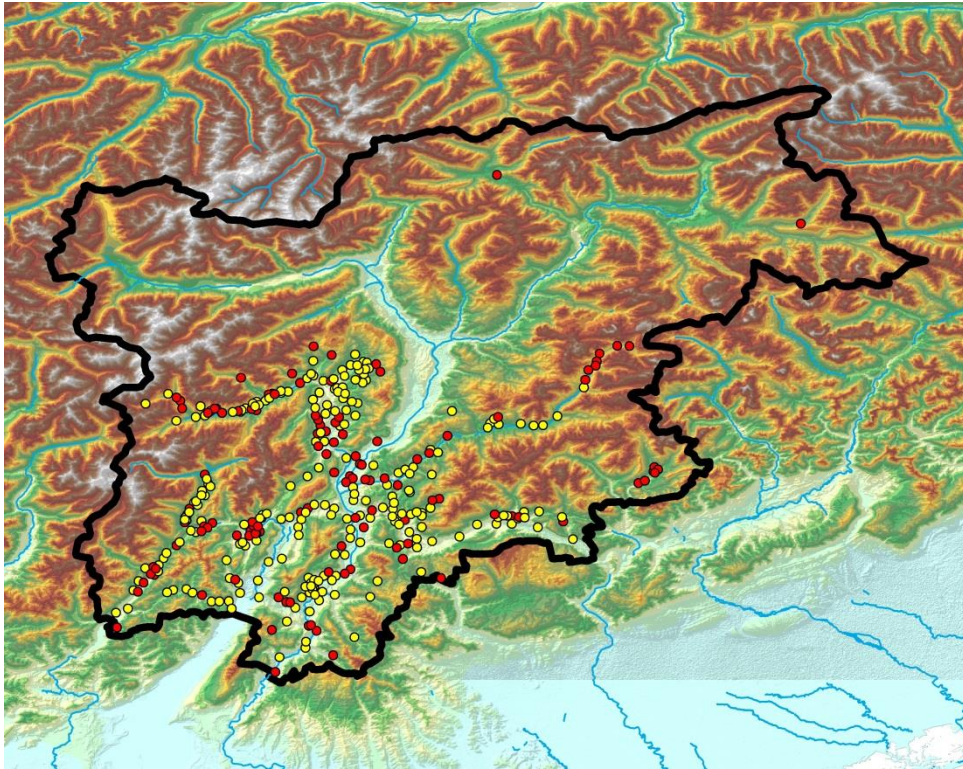
### B.3 Results

Results are summarized below, and coefficients are reported in the respective tables:

- Table B.2 (Appendix D): Institutional Choice. Main result: considering the full samples of communities in each of the observed years, population size is strongly correlated with the probability of having a *Carta di Regola*. This probability is seen to have an increasing impact with the passing of centuries.
- Table B.3 (Appendix D): Institutional Choice: Having a charter when pasture is prevalent. Main result: considering the subsample of pasture-prevalent communities in each of the observed years, population size is weakly correlated with the probability of having a *Carta di Regola*.
- Table B.4 (Appendix D): Institutional Choice: Having a charter when forest is prevalent. Main result: considering the subsample of communities where forest is prevalent in each of the observed years, population size is correlated with the probability of having a *Carta di Regola*. This probability is seen to have an increasing impact with the passing of centuries.
- Table B.5 (Appendix D): Event History Model: Risk of Adopting a Charter in 1200–1800. Main result: considering the full samples of communities observed in the time interval  $[t, t-5]$  in the period 1200–1800, population size is strongly correlated with the likelihood of adopting a *Carta di Regola*.

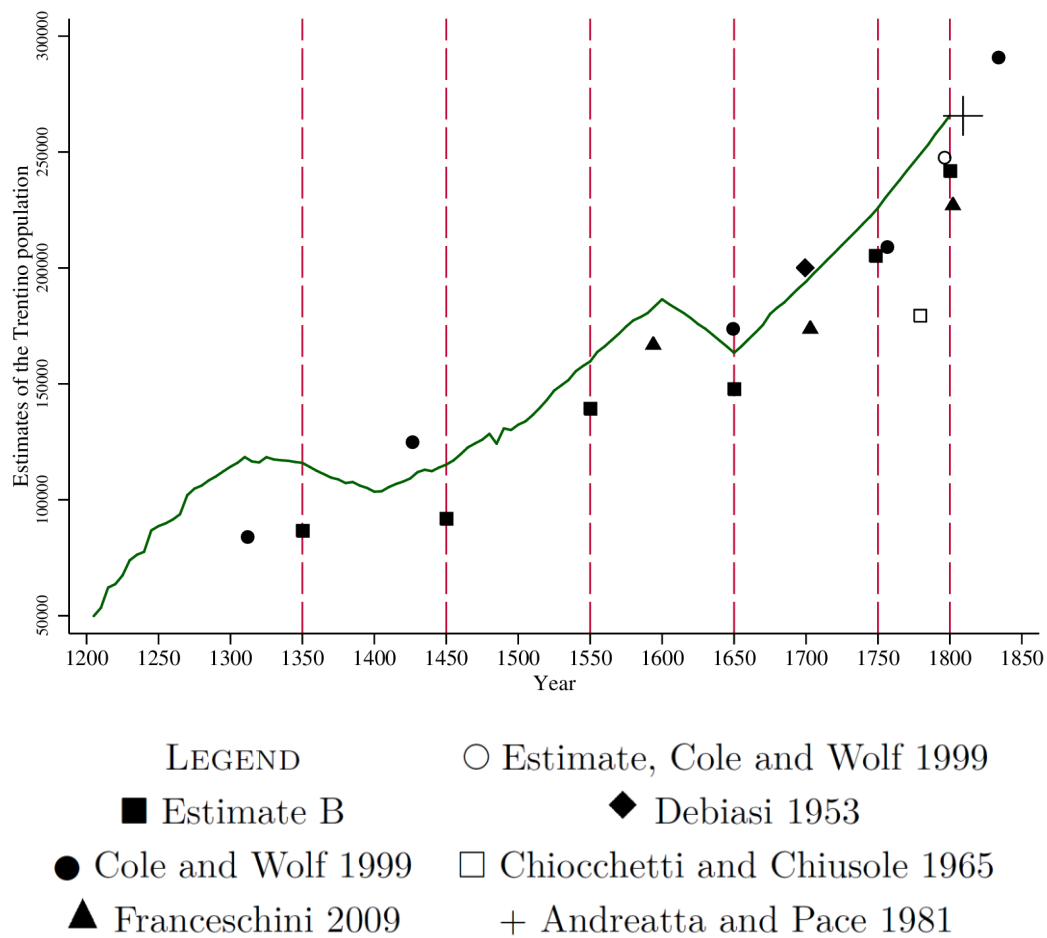






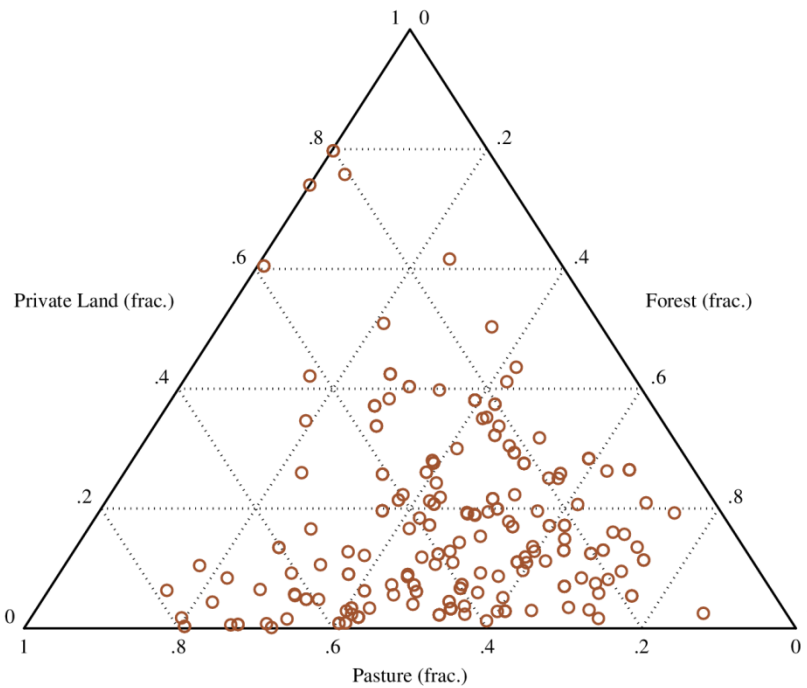
*Figure 2.4.* Carte di Regola in Trentino, 1800.

*Note.* Color map with orography. The full sample counts 354 communities, plotted on the map. Red dots indicate the non-communities in 1800 (127). Yellow dots indicate charter communities (227, 65%). Source: data from own dataset elaborated in ARCGIS using the geographical coordinates obtained using Google© API. Author: Trevor O'Grady, reproduction is not permitted.



*Figure 3.1.* Population estimates in Trentino (1200–1800).

*Note.* Estimates obtained by adding the population of all the communities in each year. Source: present author's estimates based on Andreatta and Pace (1981) and the trend of the Italian population based on Belletini (1987).



*Figure 3.2.* Heterogeneity in natural resources.

*Note.* Ternary diagram representing the fraction of private, forest, and pastureland in the 159 communities in the heterogeneity dataset. The chart shows how—due to the highly variable conditions of altitude, temperature, and position—settlements were endowed with resources in differing proportions. The chart uses the 1897 Land Register data (published in 1903). It is possible to notice the importance of the commons, forest, and pasture relative to the total productive land. Unproductive land surface is excluded from the computation of total surface.

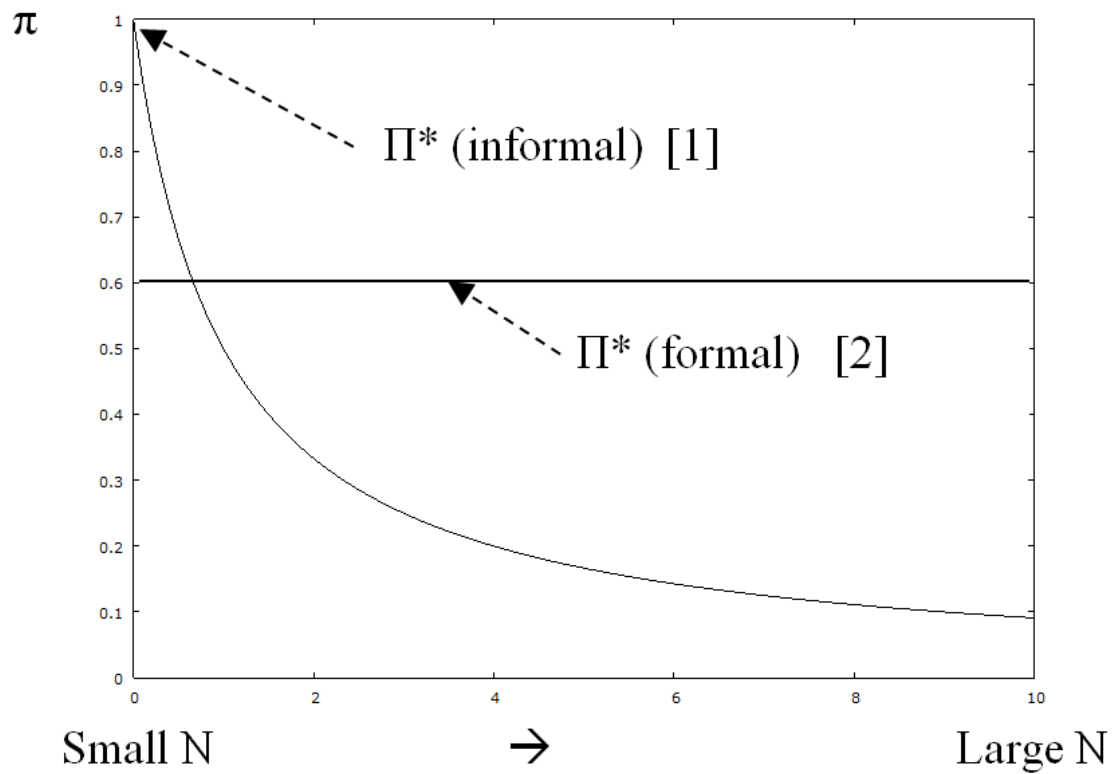


Figure 5.1. Aggregate surplus maximization on the commons.

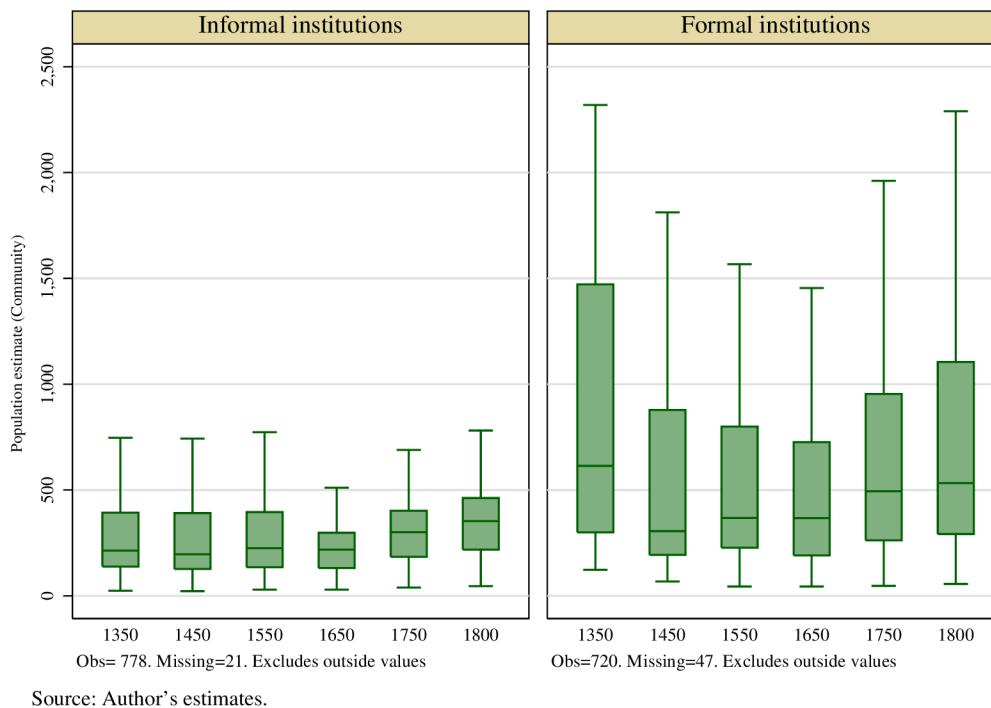


Figure 5.2. Group size estimates. Informal vs. formal institutions.

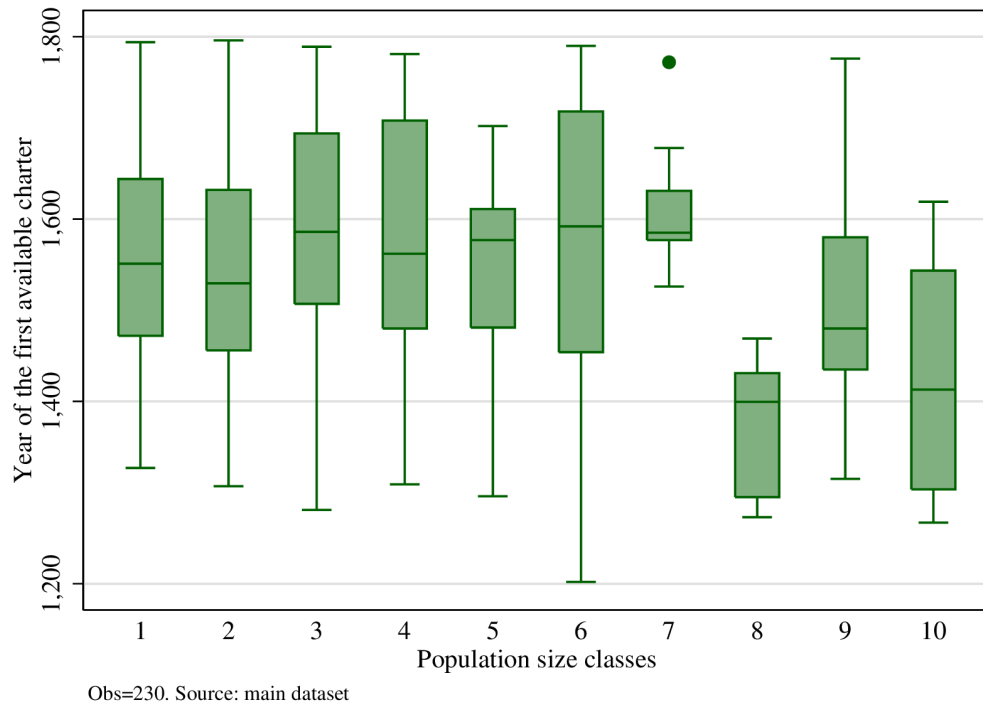


Figure 5.3. When do larger communities adopt a charter?

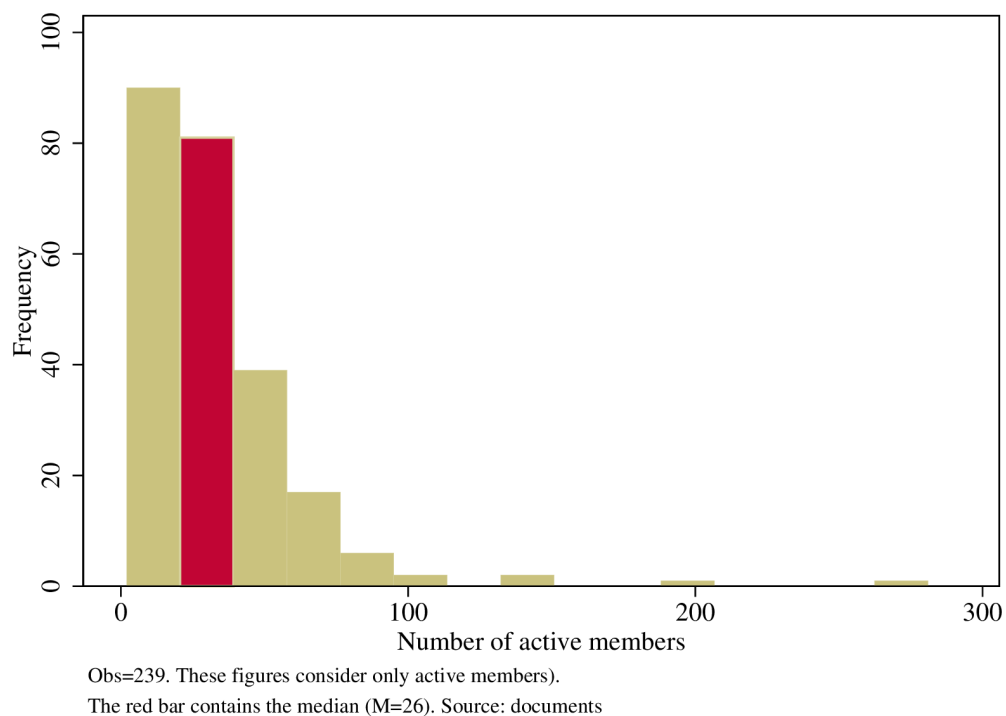
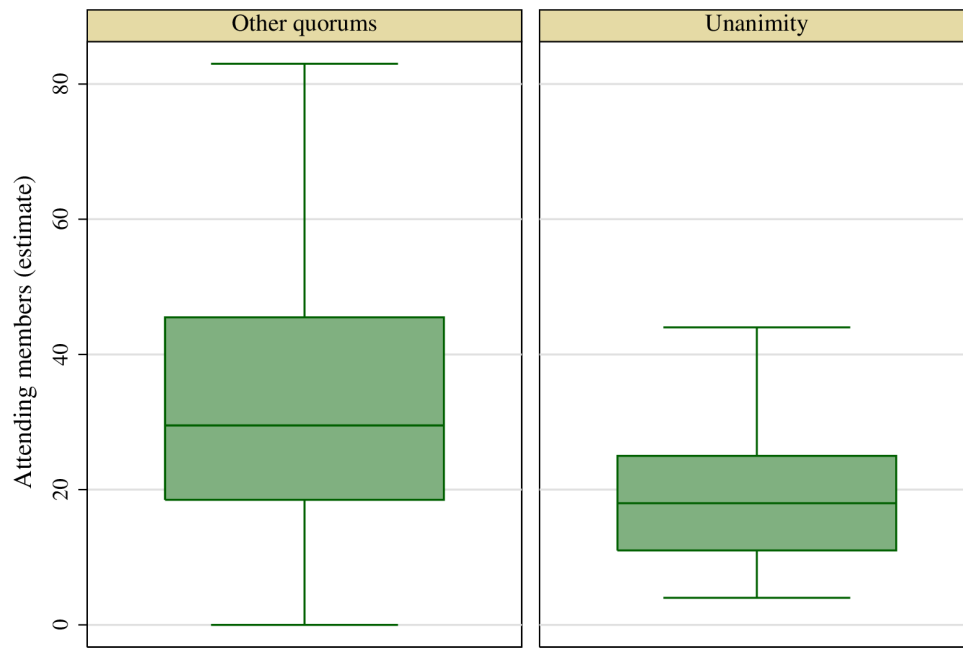
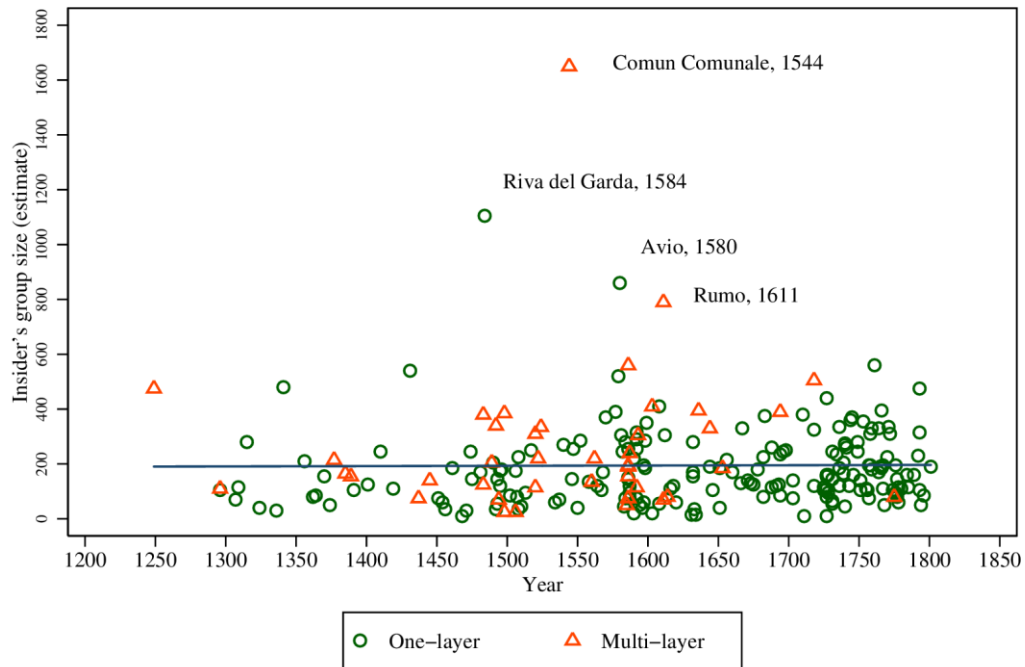


Figure 5.5. Active members in assemblies 1249–1801.



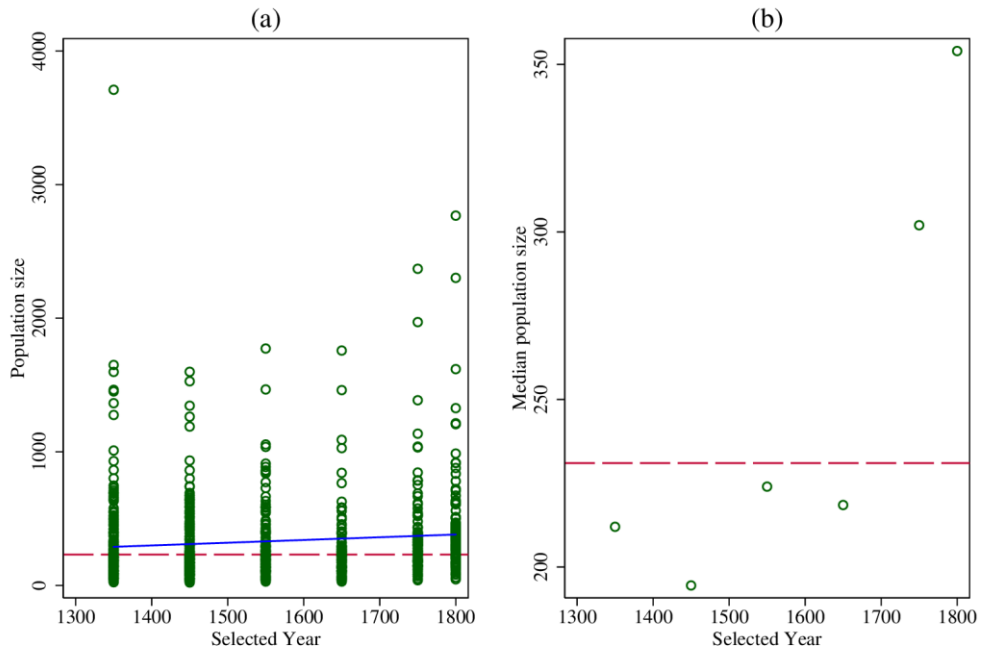
Obs.=92. Includes attending members and non-members

Figure 5.6. Participation. Unanimity vs. other quorums.



Note: Obs=239. The linear fit has intercept=183.028 and slope=0.09. Summary stats: min=10, median=155, Max= 1650  
 Source: author's estimates based on active membership in assemblies.

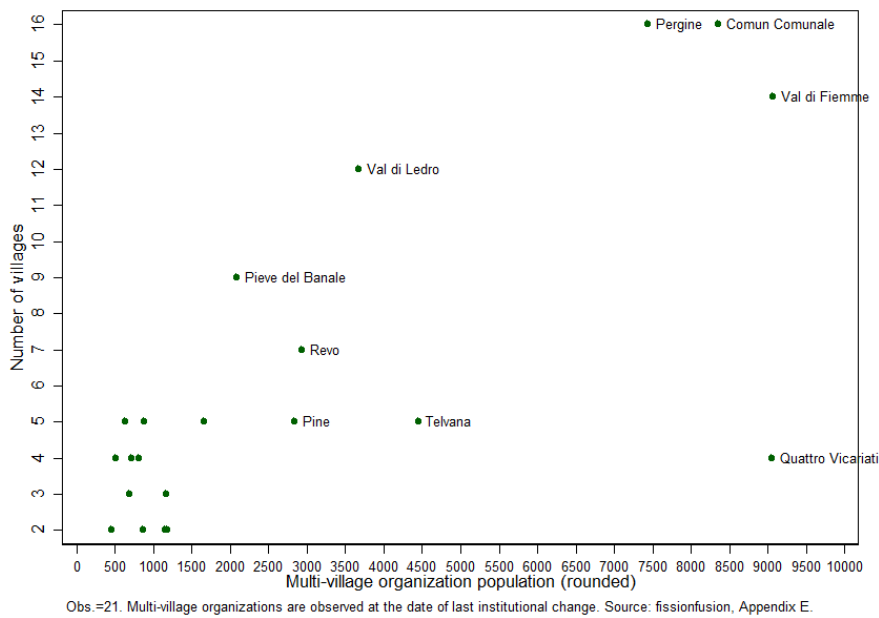
Figure 5.7.2. Number of appropriators in 1249–1801.



Source: redpanel

Figure 5.10. Upper bound group size for informal institutions.

Note. Panel (a): n=778, only informal institutions are represented. Straight line: the linear fit. Panel (b): n=6, the median population of informal institutions in each of the selected years is represented. In Panel (a) and (b), the dashed lines represent the upper bound at 231 individuals.



Obs.=21. Multi-village organizations are observed at the date of last institutional change. Source: fissionfusion, Appendix E.

Figure 6.2. Internal organization of multi-village organizations.

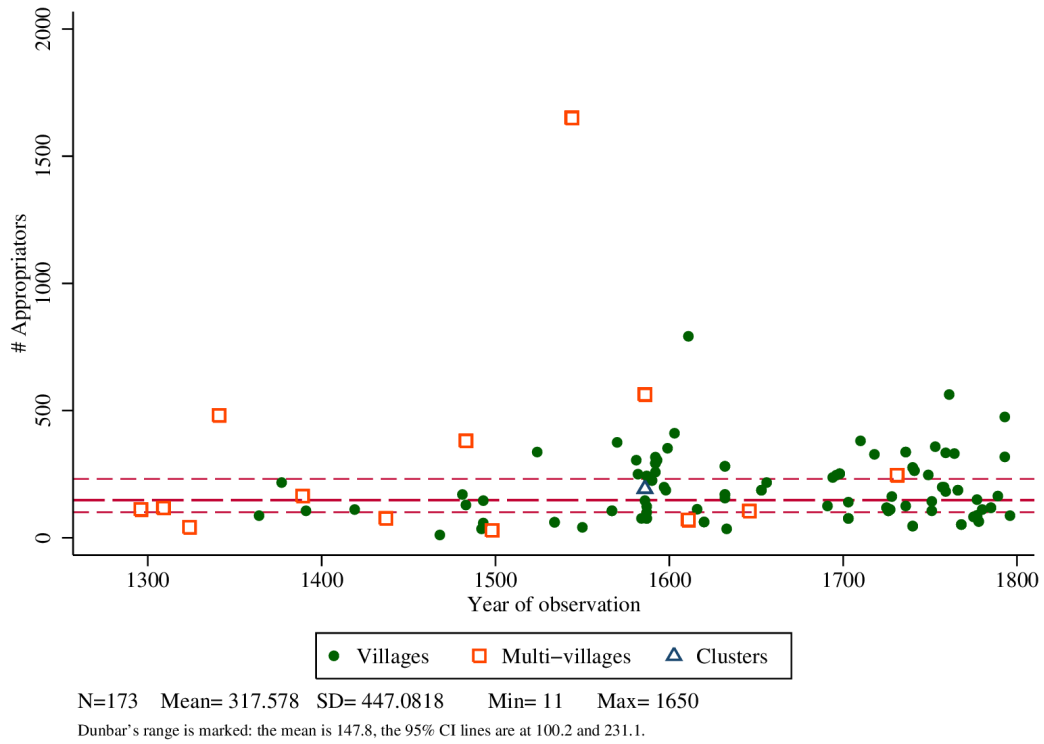


Figure 6.3. Appropriators' group size: estimates, assembly data 1296–1796.

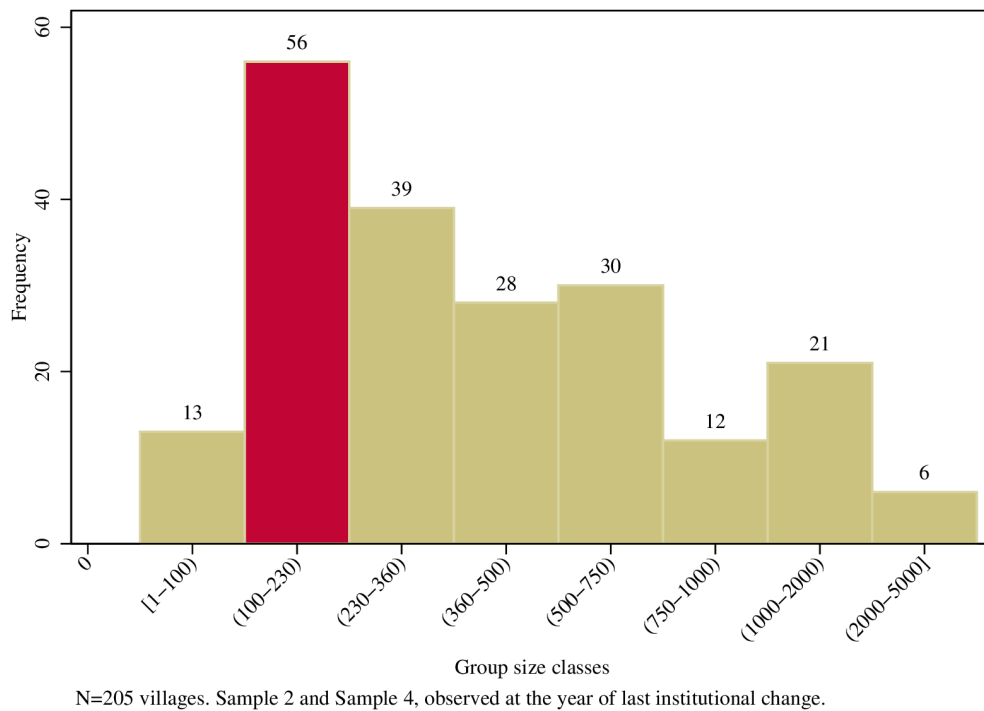


Figure 6.4. Village population distribution at last institutional change.



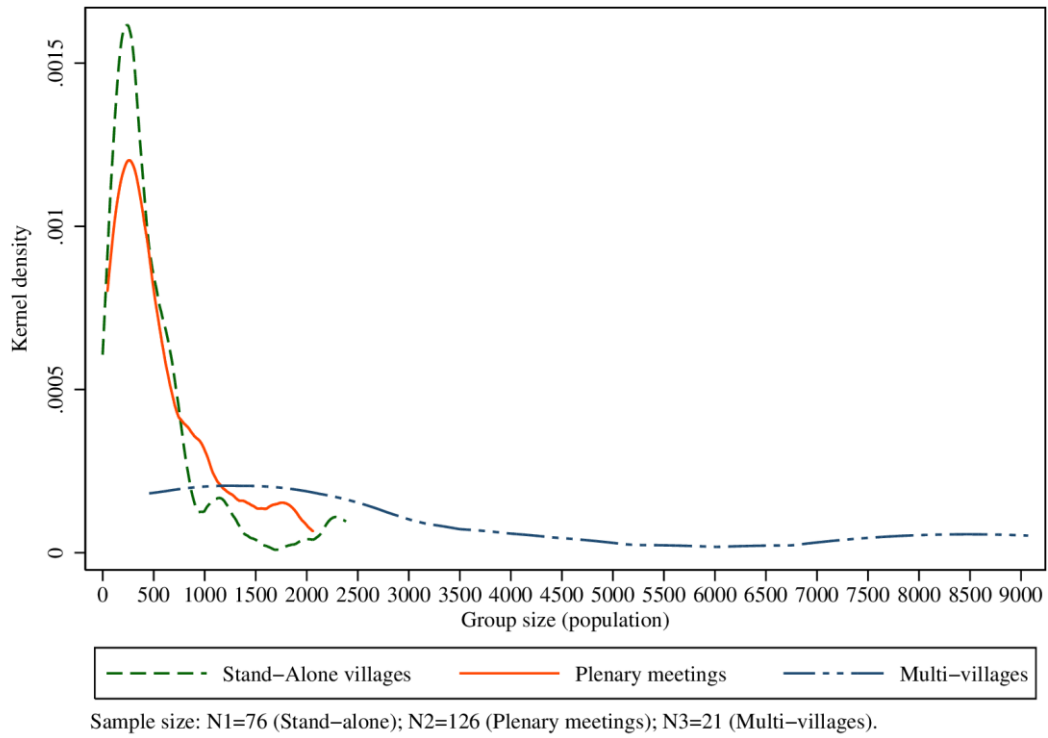


Figure 6.5. Kernel densities: Face-to-face interaction at last institutional change.

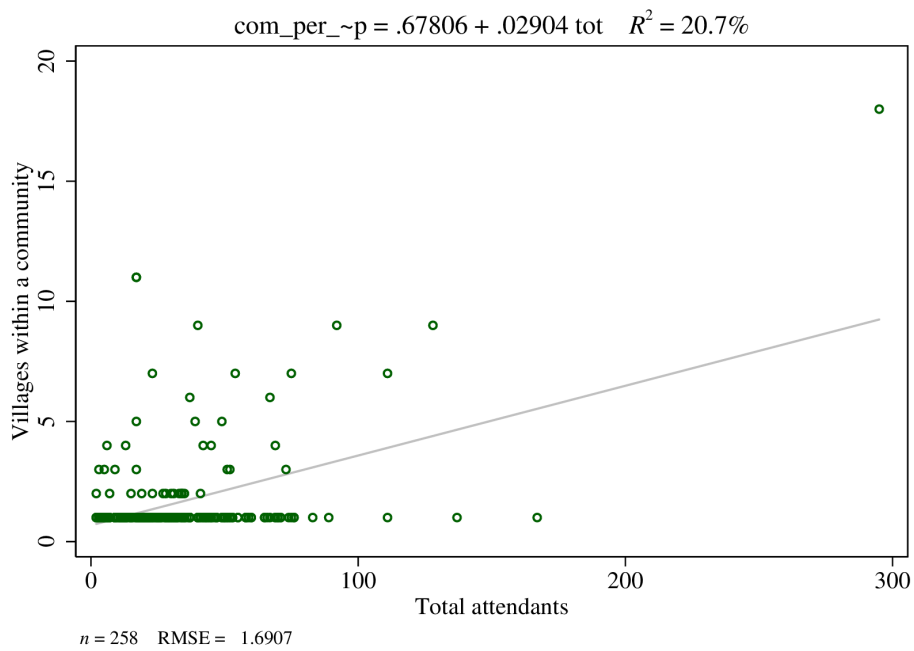
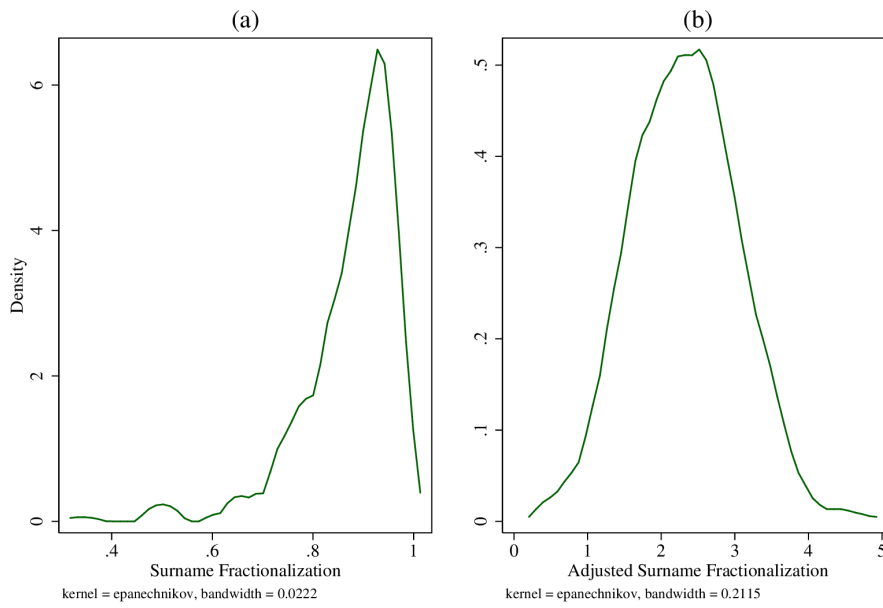


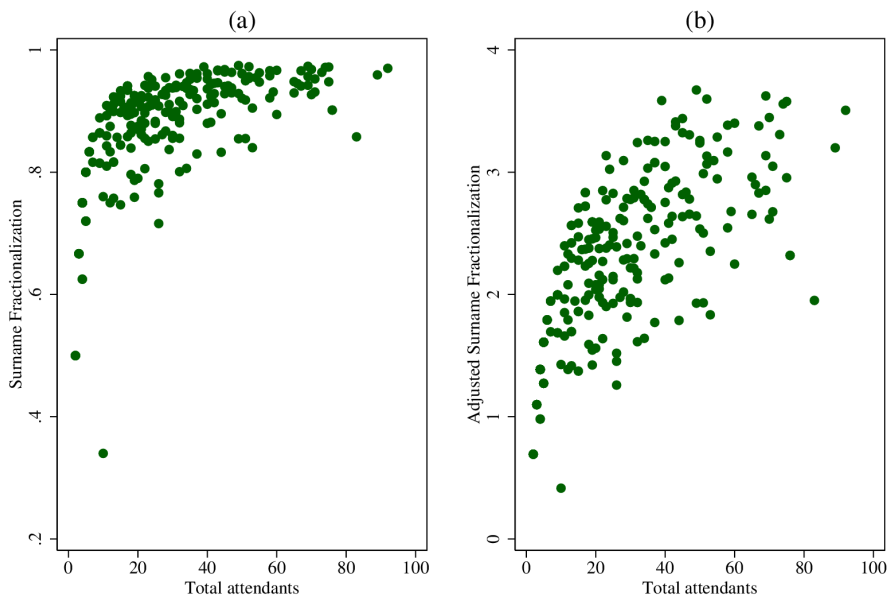
Figure 8.3. Number of villages within a community vs. assembly size.

Panel A



Note: N=258

Panel B



Note: N=252. 6 observations with total attendance >100 are omitted to improve visualization

Figure 8.5. Transformation of the surname fractionalization index.

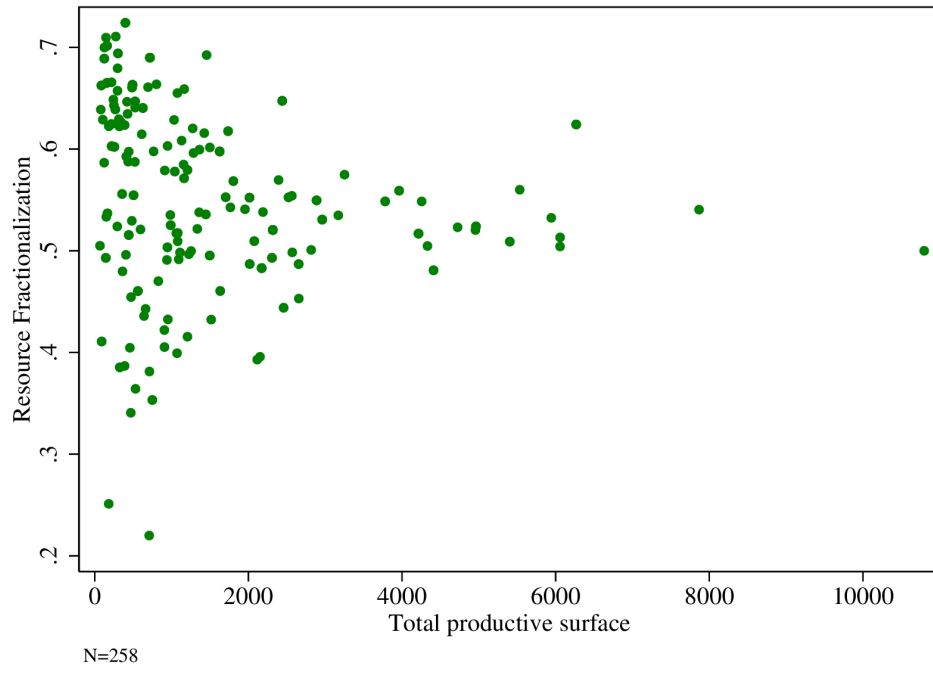
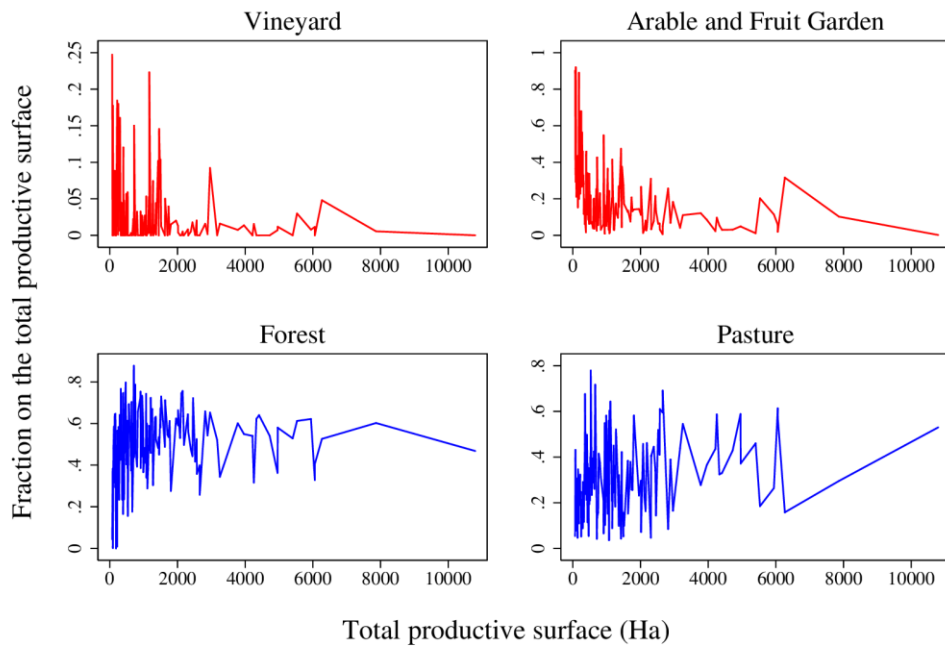


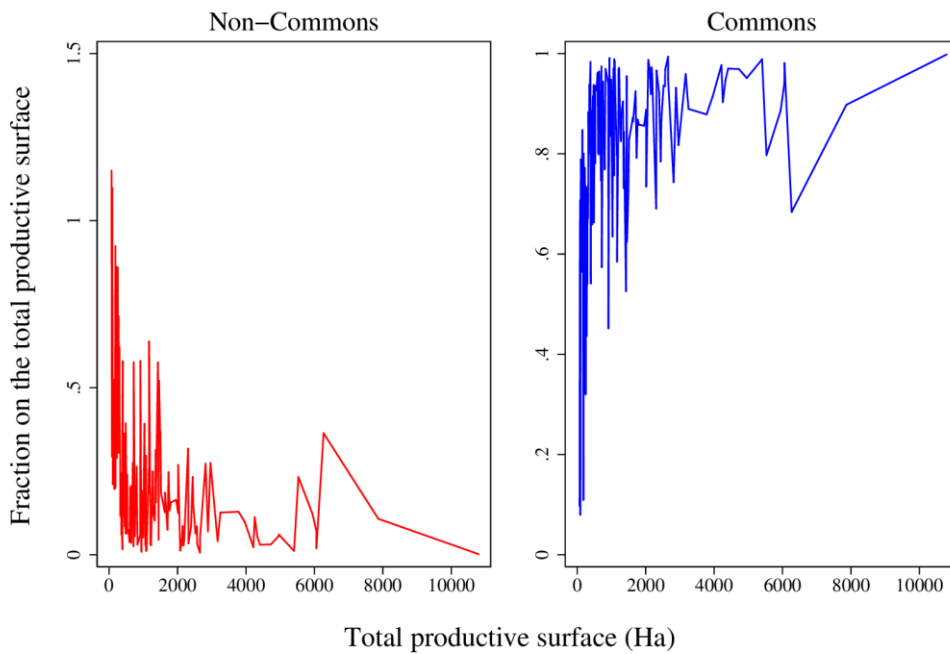
Figure 8.6. Resource fractionalization index.

## Panel A



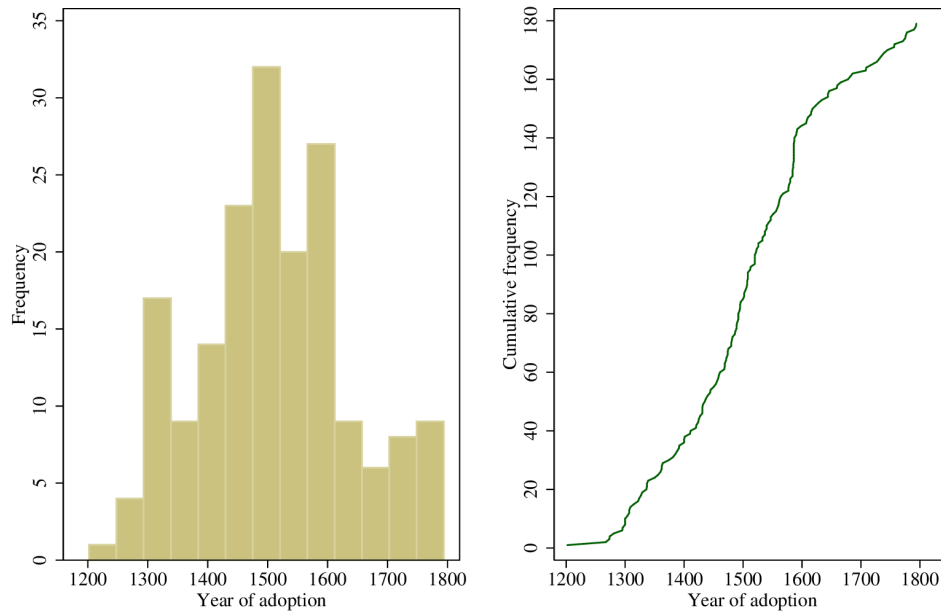
Note: N=258.

## Panel B



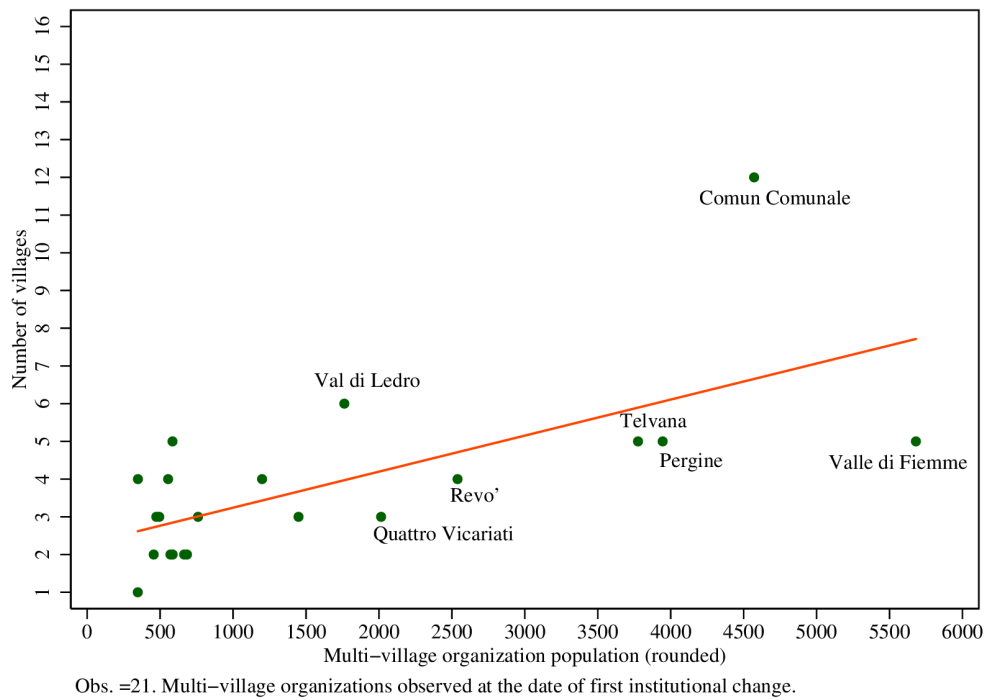
Note: N=258.

Figure 8.7. Resource heterogeneity: classes of resources.



Source: cdr; N=179, min=1202 Max=1794. Only first full charters are represented here. 10 first full charters do not report a year and do not appear in the charts.

Figure S.1. Adoption of Carte Di Regola: A time profile.



Obs. =21. Multi-village organizations observed at the date of first institutional change.

Figure S.2. Internal organization of multi-village organizations (first institutional change).

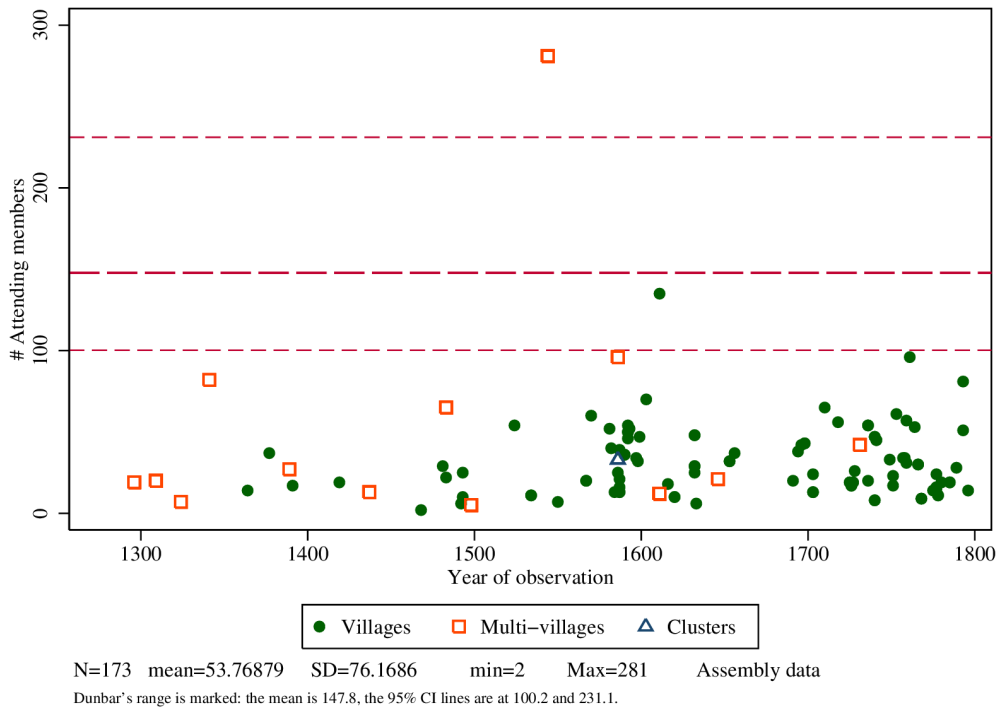


Figure S.3. Assembly size: Face-to-face meetings of group members (1296–1796).

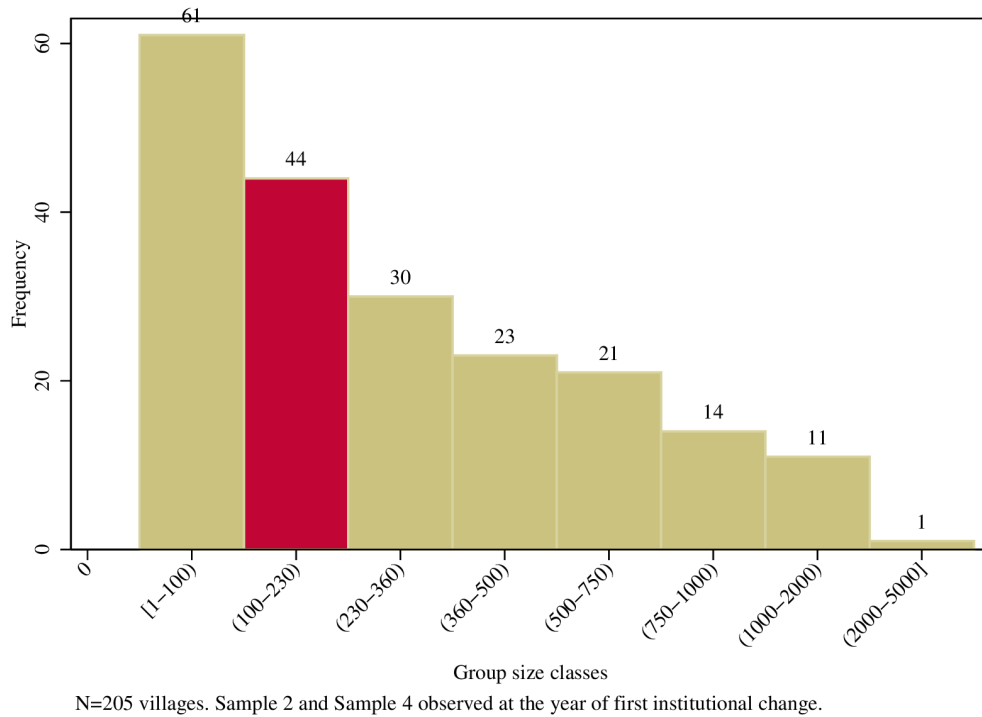


Figure S.4. Village population distribution at first institutional change.

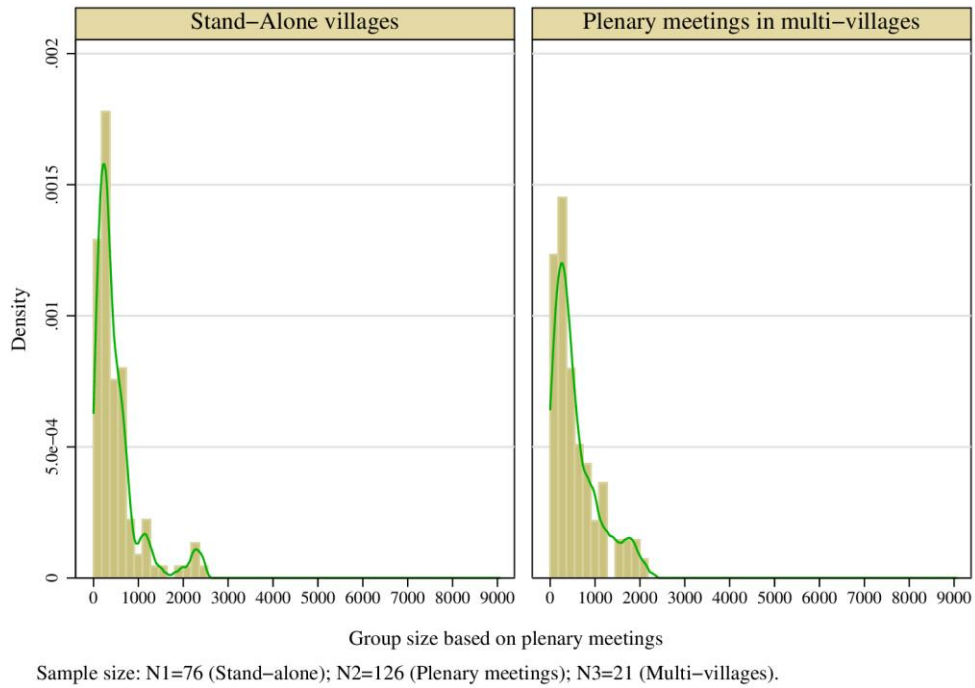


Figure S.5. Empirical distributions. Last institutional change.

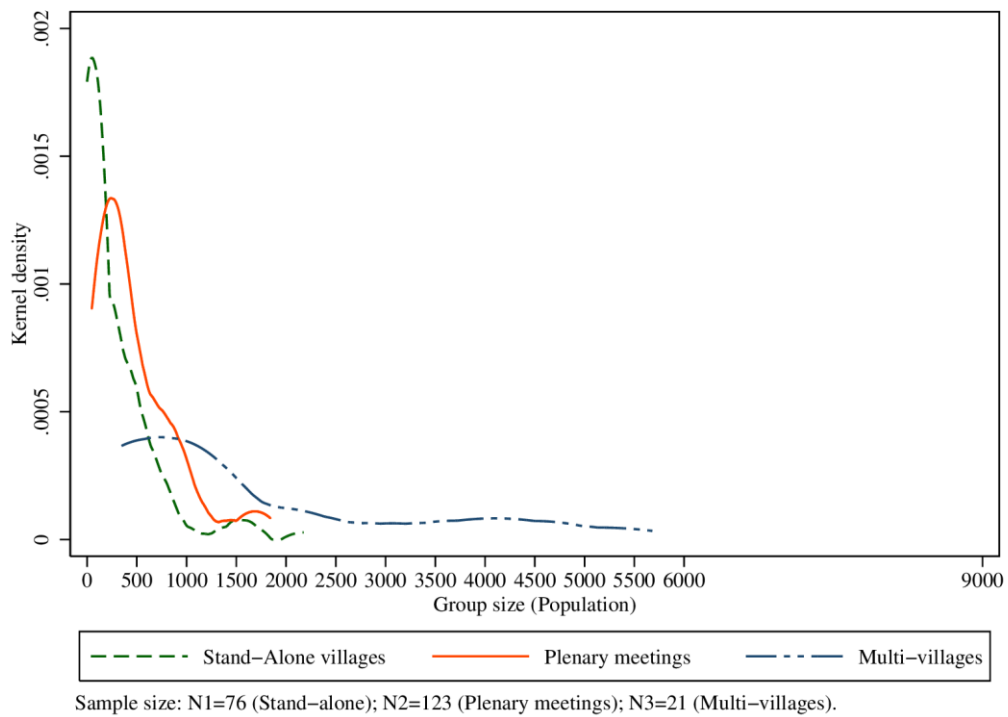
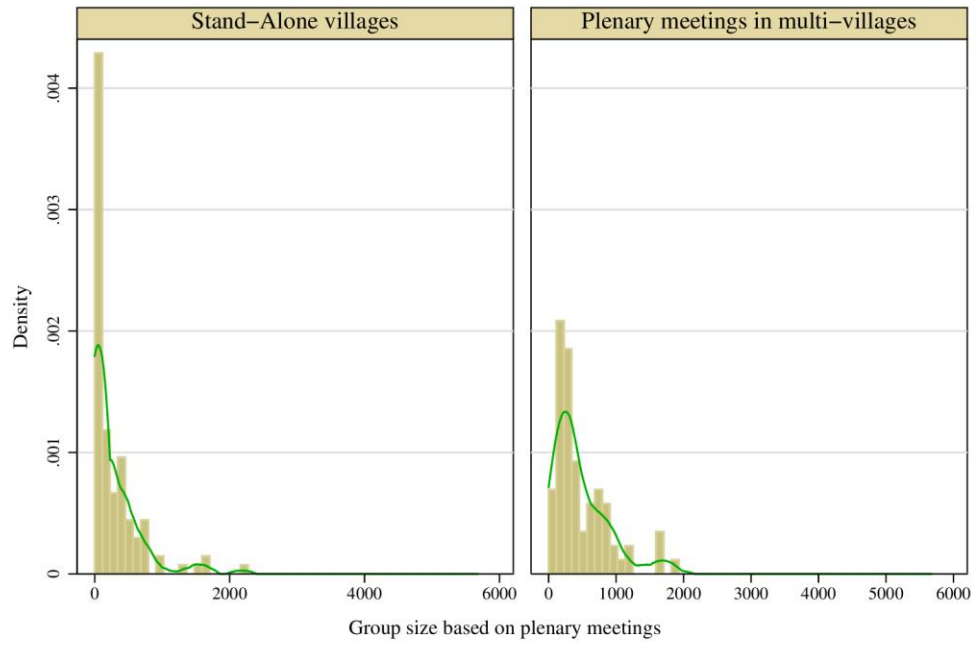


Figure S.6. Kernel density. First institutional change.



Sample size: N1=76 (Stand-alone); N2=123 (Plenary meetings); N3=21 (Multi-villages).

*Figure S.7.* Empirical distributions. First institutional change.



## APPENDIX D: TABLES

Table 3.4.

*Summary statistics: assemblies*

Variable	Mean	Std. Dev.	Min.	Max.	N
Members with voting rights	33.079	29.406	2	281	228
Members without voting rights	4.425	5.43	1	28	87
Number of non-members	3.447	1.809	1	11	179
Total attendants	31.244	29.679	2	295	258
Quorum	0.706	0.114	0.5	1	91
Villages within a community	1.585	1.895	1	18	258

Table 3.5.

*Number of appropriators on the commons (1245–1801)*

Communities	Obs.	min	Median	Max	IQR
One-layer	197	10	145	1,105	160
Multi-layer	42	25	193	1650	230

n=239. Sample: raw sample. Source: Author's estimates from assembly data.

Table 4.2.

*Group size in modern hunter-gatherer societies*

Society	Location	Mean size <sup>a</sup>			Source
		Overnight camp	Band/village	Tribe	
Walbiri	Australia	c. 25–30	221.5	886	Meggitt (1965a)
various	New Guinea	—	128.7 <sup>b</sup>	?	Ellen (1978)
Tauade <sup>c</sup>	New Guinea	27.3	202.5	1,237.3	Hallpike (1977)
Mae Enga <sup>d</sup>	New Guinea	48	90 (350)	2,290	Meggitt (1965b)
Gebusi	New Guinea	26.5 <sup>e</sup>	53–159	450	Knauff (1987)
Kaluli	New Guinea	60.0 <sup>f</sup>	109.1	1,200	Schieffelin (1976)
Ruhua Nualu	Indonesia	—	180.0 <sup>b</sup>	?	Ellen (1978)
Bihar	India	26.8	90–120	c. 1,625	Williams (1974)
Andamanese	Andaman Is	40–50	?	471	Williams (1974)
G/wi San	S. Africa	21–85	?	2,000	Silberbauer (1972)
!Kung San	Botswana	18.6	152.3	2,693	Lee (1982)
Mbuti	Zaire	—	60–150 <sup>b</sup>	?	Harako (1981)
					Turnbull (1968)
Aka	W. Congo	25–35	60–100	(c. 1,050+)	Hewlett (1988)
Ammassalik	Greenland	31.8	?	413	Service (1962)
Inuit	Canada	?	150.0	483	Irwin (1987)
Central Eskimo	Canada	?	c. 100	600	Damas (1968)
Dogrib	USA	c. 10–60	c. 60–250 <sup>f</sup>	?	Helm (1968)
Shoshone	USA	62.7	?	?	Service (1962)
California Indians	USA	c. 50–75	?	?	Steward (1955)
Yanomamo	Venezuela	—	101.9 <sup>b</sup>	663 <sup>e</sup>	Chagnon (1979)
Ona	Tierra del Fuego	40–120	?	?	Steward (1936)
Mean <sup>h</sup> :		37.7	148.4 <sup>i</sup>	1,154.7	
Sample size:		8	9	13	
Coefficient of variation (%):		41.7	29.1	64.4	

<sup>a</sup>Some sources only give a range in group size. “?” indicates that the level of grouping is specifically mentioned by the ethnographer, but no census data are given; “—” indicates that the grouping specifically does not occur.

<sup>b</sup>Settled hunter-gatherers or traditional horticulturalists living in permanent villages.

<sup>c</sup>The values are, respectively, the mean size of clans, tribes, and dialects, as defined by Hallpike (1977), from a total language group of about 8,700; this interpretation is closest to the usage in the target article.

<sup>d</sup>The values are, respectively, the mean size of patrilineages, subclans (clans in parentheses), and phratries, as defined by Meggitt (1965b), from a total tribal group estimated at 60,000 (see comment on note [c], above).

<sup>e</sup>Helm (1968) quotes sizes as numbers of “conjugal pairs”; I have assumed an average of three living children per conjugal pair.

<sup>f</sup>Mean number of residents in a longhouse.

<sup>g</sup>Mean size of “population blocs” of Chagnon (1979) from a total Yanomamo population estimated to be about 15,000.

<sup>h</sup>For societies in which actual census data are given.

<sup>i</sup>The larger value for the Mae Enga would give a mean of 177.3; the median values would be 150.0 and 152.3, respectively.

Note. Reproduced from Dunbar (1993).

Table 5.2.

*Population estimates 1350–1800: summary statistics*

Year	Informal Institutions						Formal Institutions					
	1350	1450	1550	1650	1750	1800	1350	1450	1550	1650	1750	1800
min	24	22	29	29	39	46	123	68	44	44	47	56
25%	131	122	137	131	186	218	300	193	207	183	258	273
<b>Median</b>	<b>212</b>	<b>195</b>	<b>224</b>	<b>219</b>	<b>302</b>	<b>354</b>	<b>614</b>	<b>306</b>	<b>365</b>	<b>363</b>	<b>473</b>	<b>527</b>
75%	391	367	392	297	395	462	1,472	878	793	726	954	1,104
Max	3,710	1,599	1,773	1,758	2,370	2,768	3,459	3,836	6,074	8,273	11,150	13,021
IQR	260	245	255	166	209	244	1172	685	586	543	696	831
Obs.	171	164	125	110	105	103	26	54	123	159	174	184

*Note.* n=1498, observation unit: community. Source: Author's estimates.

Table 5.3.

*Median year of first charter adoption and group size classes*

Class	Size interval	Gap	Obs.	Year	
				Median	IQR
1	<150	150	45	1551	172
2	151-300	150	62	1530	176
3	301-450	150	29	1586	187
4	451-600	150	27	1562	228
5	601-750	150	19	1577	130
6	751-900	150	15	1592	264
7	901-1,200	300	9	1585	54
8	1,201-1,500	300	6	1400	136
9	1,501-2,000	500	6	1480	145
10	>2,000	–	12	1413	240

*Note.* n=230, 11 missing values in population. Source: Author's estimates.

Table 5.4.

*Transaction costs: resources*

Selected Year		Institutions		Median Test		Probability
		Informal	Formal	$\chi^2$	<i>p</i> -value	
1350	Pasture	217	596	6.2173	0.013**	0.202
	Obs.	62	13			
	Forest	210	336	0.5100	0.475	0.283
	Obs.	61	9			
1450	Pasture	204.5	278	1.0633	0.302	0.401
	Obs.	66	23			
	Forest	178.5	305.5	5.6077	0.018**	0.245
	Obs.	52	20			
1550	Pasture	231	366	1.4918	0.222	0.348
	Obs.	43	55			
	Forest	221	321	2.9227	0.087*	0.361
	Obs.	47	41			
1650	Pasture	226	317.5	2.1217	0.222	0.352
	Obs.	34	72			
	Forest	219	369.5	3.7125	0.054*	0.313
	Obs.	45	54			
1750	Pasture	314.5	446	3.2500	0.071*	0.360
	Obs.	34	73			
	Forest	296	494	5.7095	0.017**	0.322
	Obs.	43	61			
1800	Pasture	367.5	479	2.9763	0.084*	0.369
	Obs.	38	75			
	Forest	349.5	502	4.5544	0.033**	0.345
	Obs.	40	65			

Obs.tot=1498, Obs.(informal)=778, Obs.(formal)=720. Observation unit: community. The panel *Institutions* in first line of each year displays the median population estimate, while the second the number of observations per type. The panel *Median test* displays the Pearson  $\chi^2$  and *p*-value of the test, both continuity corrected (significance levels: \*\*\*  $p < 0.01$ , \*\*  $p < 0.05$ , \*  $p < 0.1$ ). The panel *Probability* displays an estimate of the probability that a community randomly drawn from the group *informal* has a population larger than the one of a community randomly drawn from the group *formal*. We omitted the *z*-values and *p*-values of the Wilcoxon rank-sum test ( $H_0$ : population(event=informal)=population(event=formal)), always at least 10% significant apart from the years 1350 and 1450 in communities where pasture is prevalent.

Table 5.5.

*Transaction costs: remoteness from closest town*

Selected Year		Institutions		Median Test		Probability
		Informal	Formal	$\chi^2$	<i>p</i> -value	
1350	More isolated	188	562	4.6667	0.031**	0.247
	Obs.	85	10			
	Less isolated	237	644.5	6.9259	0.008***	0.149
	Obs.	86	16			
1450	More isolated	173.5	260.5	4.6005	0.032**	0.363
	Obs.	74	24			
	Less isolated	205.5	382	4.3584	0.037**	0.274
	Obs.	90	30			
1550	More isolated	219.5	321	4.1123	0.043**	0.355
	Obs.	66	49			
	Less isolated	231	373	7.8844	0.005***	0.313
	Obs.	59	74			
1650	More isolated	201	314	4.1854	0.041**	0.372
	Obs.	64	59			
	Less isolated	230.5	380	17.5858	0.000***	0.277
	Obs.	46	100			
1750	More isolated	296.5	413	3.6714	0.055*	0.402
	Obs.	62	64			
	Less isolated	309	512	23.4650	0.000***	0.250
	Obs.	43	110			
1800	More isolated	344	471	0.247	0.055*	0.425
	Obs.	61	67			
	Less isolated	371	558	19.8509	0.000***	0.272
	Obs.	42	117			

Obs.tot=1498, Obs.(informal)=778, Obs.(formal)=720. Observation unit: community. Remoteness is measured as linear distance in kilometers from the closest local town: *More isolated* communities have a distance from the local town above the sample median. The panel *Institutions* in first line of each year displays the median population estimate, while the second the number of observations per type. The panel *Median test* displays the Pearson  $\chi^2$  and *p*-value of the test, both continuity corrected (significance levels: \*\*\*  $p < 0.01$ , \*\*  $p < 0.05$ , \*  $p < 0.1$ ). The panel *Probability* displays an estimate of the probability that a community randomly drawn from the group *informal* has a population larger than the one of a community randomly drawn from the group *formal*. We omitted the *z*-values and *p*-values of the Wilcoxon rank-sum test ( $H_0$ : population(event=informal)=population(event=formal)), always at least 10% significant apart from the years 1350 and 1450 in communities where pasture is prevalent.

Table 5.7.

*Number of appropriators (1245–1801)*

<b>Communities</b>	<b>Obs.</b>	<b>min</b>	<b>Median</b>	<b>Max</b>	<b>IQR</b>
Raw sample (Multi-layer <i>packed</i> )	239	10	155	1,650	170

Table 6.1.

*Assembly levels*

<b>Organization</b>	<b>Institution</b>	<b>Governance Structure</b>	
		<b>SINGLE-LAYER</b>	<b>MULTI-LAYER</b>
STAND-ALONE	<i>Informal</i>	<i>Not observable</i>	–
	<i>Formal</i>	Village	–
SINGLE VILLAGE	<i>Informal</i>	Village	<i>Village</i>
	<i>Formal</i>	Village	Village
CLUSTER	<i>Informal</i>	Village	<i>Village</i>
	<i>Formal</i>	Village	Village / Cluster
MULTI-VILLAGE	<i>Informal</i>	Village	<i>Village</i>
	<i>Formal</i>	Village	Village / Cluster / Multi-village

Note. The table summarizes the levels of aggregation available to each group (village) observed: village, cluster, multi-village. The available assembly levels vary according to the organization adopted by the group, and on the resulting governance structure. In informal groups, assemblies are assumed to be replaced by informal interaction. In formal groups, when assembly levels are available other than the village level, higher levels are assumed to be attended by representatives unless otherwise reported by the documents. I focus on the largest grouping of face-to-face interactants. Group size in stand-alone villages under informal institutions is not observable, and therefore communities belonging to this sample are not included in the analyses. Villages, clusters and multi-villages under formal institutions have changes that are *directly observed*, while institutional changes of all the villages under single layer governance and informal institution are *indirectly observed* when a change in the multi-village they belong occurs (in table these villages are indicated in *italics*).

Table 6.2.

*Categories and samples*

Number of Villages	Categories				
	Organization	Level	Structure	Assembly	Sample used
1	Single village	V	1 Layer	YES/NO	<i>Sample 2</i>
	Stand alone	V		YES	<i>Sample 4</i>
2	Multi village	C	2 Layer	YES/NO	<i>Sample 3</i>
		MV		YES	<i>Sample 1</i>
3+	Multi village	C	3 Layer	YES/NO	<i>Sample 3</i>
		MCV	4 Layer	YES	<i>Sample 1</i>



Table 6.3. *Case selection: list of multi-villages*

Case No. <i>Sample 1</i>	Multi village Organizations	Year ( <i>last</i> )	No. Villages ( <i>last</i> )	Population ( <i>last</i> )	Lev Sample used	No. Units
1	Giovo, Faedo	1757	2	456	MV	2
2	Quattro Vicariati	1619	4	517	MV	4
3	Cogolo e Celledizzo	1580	2	636	MV	2
4	Roncone, Lardaro	1793	2	694	MV	2
5	Telve di Sopra	1648	4	721	MV	4
6	Bresimo	1671	5	812	MCV	2
7	Revo	1633	7	864	MV	7
8	Condino, Brione	1751	2	879	MV	2
9	Pine	1764	5	1155	MV	5
10	Coredo, Smarano, Sfruz	1696	3	1173	MV	3
11	Romeno, Don, Amblar	1694	3	1186	MV	3
12	San Sisinio	1728	5	1667	MV	5
13	Telvana	1631	5	2089	MV	5
14	Malosco	1746	4	2842	MV	4
15	Commezzadura	1731	4	2940	MV	4
16	Comun Comunale	1796	16	3674	MV	16
17	Pieve del Banale	1751	9	4449	MV	9
18	Pergine	1780	16	7436	MV	16
19	Val di Gresta	1789	5	8357	MV	5
20	Val di Ledro	1793	12	9049	MV	12
21	Val di Fiemme	1783	14	9069	MV	14
<b>Total villages (Sample 2):</b>			129			126
<b>Stand-Alone village organizations (Sample 4) :</b>			76			
<b>TOTAL VILLAGES (Sample 2 + Sample 4):</b>			205			

Source: fissionfusion13.dta.

Table 6.4.

*Internal organization at last institutional change*

<b>Internal Organization: Levels</b>	<b>Freq.</b>	<b>Percent</b>
Informal	5	2.44
One-Layer	142	69.27
Two-Layer	43	20.98
Three-Layer	14	6.83
Four-Layer	1	0.48
<b>Total</b>	<b>205</b>	<b>100.00</b>

*Note:* the frequencies include also 76 stand-alone villages in the one-layer class. The only case of four-layer community is Revo: Rumo is a multi-village coordinating seven villages of which we have neither the population for 1810 nor a charter.

Table 6.5.

*Internal structure at last institutional change: villages detail.*

<b>Organization structure of multi-villages</b>	<b>Code</b>	<b>Freq.</b>	<b>Percent</b>
Informal management at village level	000	5	2.44
One-Layer: village	100	90	43.9
One-Layer: multi-village	001	32	15.61
One-Layer: cluster	010	20	9.76
Two-Layer: village and multi-village	101	18	8.78
Two-Layer: cluster and multi-village	011	21	10.24
Two-Layer: village and cluster	110	4	1.95
Three-Layer: village, cluster and multi-village	111	14	6.83
Four-Layer: sub-villages, village, cluster, multi-village	444	1	0.48
<b>Total</b>		<b>205</b>	<b>100</b>

Table 6.6.

*Internal structure at last institutional change: multi-villages*

Layers		Multi-villages	
Type	Detail	No.	Percent
1 Layer	V	3	14.28
2 Layer	MV	10	47.62
3 Layer	MCV	7	33.34
4 Layer	MCV+	1	4.76
<b>Total</b>		<b>21</b>	<b>100</b>

Table 6.7.

*Internal structure at last institutional change: multi-villages detail*

Unit of obs.	Sample	Obs.	Population size				Period
			min	Median	Max	IQR	
<i>Village</i> <sup>(1)</sup>	2	718	23	318	2384	403	1267-1796
<i>Stand – alone(first)</i>	4	76	48	306	1841	526	1287-1785
<i>Stand – alone(last)</i>	4	76	48	306	2061	566	1331-1795
<i>Cluster</i> <sup>(2)</sup>	3	129	169	1042	6259	1197	1300-1796
<i>Multi – village</i> <sup>(3)</sup>	1	115	347	1449	9179	3878	1267-1796

Note: (1) removed 143 observations with population set to 0; (2) figure referred to 28 clusters, removed 1 observation with population set to 0; (3) figure referred to 21 multi-village organizations.

Table 6.8.

*Appropriators' group size: estimates on assembly data (1296–1796)*

Unit of obs.	Sample	Obs.	Median	IQR	min	Max	Period
Village	2	40	151	143	11	792	1364-1796
Stand-Alone (first)	4	23	118	141	46	337	1377-1785
Stand-Alone (last)	4	28	179	217	46	411	1524-1785
Cluster	3	1	193	0	193	193	1586
Multi-village	1	13	117	305	29	1650	1296-1731

Source: fissionfusion13.dta

Table 8.3.

*Surname fractionalization: summary statistics*

Variable	Mean	Std. Dev.	Min.	Max.
Historical Surname Fractionalization	0.875	0.095	0.34	0.991
Simulated Surname Fractionalization	0.923	0.09	0.5	0.996
N		258		

Table 8.4.

*Surname fractionalization: cross-correlation table*

Variables	1	2	3	
Historical Surname Fractionalization	1	1.000		
Simulated Surname Fractionalization	2	0.815	1.000	
Total attendants	3	0.514	0.515	1.000

Table 8.6.

*Resource fractionalization: summary statistics*

Variable	Mean	Std. Dev.	Min.	Max.
Historical Resource Fractionalization	0.554	0.087	0.22	0.724
Simulated Resource Fractionalization	0.584	0.001	0.576	0.586
N		258		

Table 8.7.

*Resource fractionalization: cross-correlation table*

Variables	1	2	3	
Historical Resource Fractionalization	1	1.000		
Simulated Resource Fractionalization	2	-0.186	1.000	
Total productive surface	3	-0.212	0.513	1.000

Table 8.8.

*Consensus in assemblies: quorums*

Quorum	Freq.	Percent
1/2	5	5.49
2/3	64	70.33
3/4	8	8.79
4/5	4	4.4
8/9	1	1.1
Unanimity	9	9.89
<i>Total</i>	<i>91</i>	<i>100</i>

Table 8.11.

*Mean number of articles per type*

Type of rules	Surname Fractionalization							
	<i>Low</i>		<i>Medium</i>		<i>High</i>		<i>Total</i>	
	Mean	SE	Mean	SE	Mean	SE	Mean	SE
Community Governance (n=228)	10.06	(1.57)	13.15	(1.81)	14.07	(1.54)	12.49	(0.95)
Resource Management (n=224)	19.06	(2.86)	25.26	(3.18)	30.64	(3.01)	24.83	(1.79)

*Source: heterogeneity6.dta.**Note:* the adjusted surname fractionalization index is used.

Table 8.13.

*Content of regulation (standardized coefficients)*

	(1)	(2)	(3)	(4)	(5)	(6)	(7)
Adjusted Surname Fractionalization	0.173**		0.221***	0.141*		0.173**	0.251***
Adj. Surname Fract. × Assembly Size	-0.589**		-0.003	-0.331		0.077	0.134
Resource Fractionalization	-0.062	-0.069	-0.060	0.064	0.060	0.066	-0.066
Villages within a community	-0.103	-0.150*	-0.142*	-0.182**	-0.210***	-0.209***	0.007
Total attendants	0.621**	0.183***		0.432	0.216**		-0.300
Total productive surface	-0.048	-0.065	-0.044	0.138*	0.126*	0.141*	-0.056
Charter amendment	-0.495***	-0.513***	-0.509***	-0.466***	-0.480***	-0.476***	-0.027
Large commons endowment	-0.010	0.014	-0.014	-0.025	-0.002	-0.028	-0.106
Distance from closest local town	-0.013	-0.016	0.005	0.006	-0.002	0.017	0.013
Observations	228	228	228	224	224	224	224
$R^2$	0.45	0.42	0.44	0.40	0.38	0.39	0.23
Number of Communities	147	147	147	145	145	145	145
Time Trend	YES	YES	YES	YES	YES	YES	YES
Area Fixed Effects	YES	YES	YES	YES	YES	YES	YES

OLS, robust standard errors in parentheses clustered per community. Dependent: number of articles of each type.

\*  $p < 0.10$ , \*\*  $p < 0.05$ , \*\*\*  $p < 0.01$

Table 8.16.

*Forward stability of the institution (uncensored observations)*

	(1)	(2)	(3)	(4)	(5)
Adjusted Surname Fractionalization	-0.059		-0.088	0.009	0.007
Adj. Surname Fract. × Assembly Size	-0.133		-0.084	0.599	1.080
Resource Fractionalization		-0.285*	-0.275*	-0.058	0.140
Villages within a community				-0.199	-0.188
Total attendants				-0.603	-1.143
Total productive surface				0.049	0.377
Charter amendment				0.319*	0.105
Large commons endowment				0.127	0.216
Distance from closest local town				0.315	0.233
Observations	62	62	62	62	62
$R^2$	0.03	0.08	0.11	0.24	0.53
Number of Communities	40	40	40	40	40
Time Trend	NO	NO	NO	NO	YES
Area Fixed Effects	NO	NO	NO	NO	YES

OLS (standardized coefficients), robust standard errors in parentheses clustered per community.  
 Dependent: forward duration (in years).

\*  $p < 0.10$ , \*\*  $p < 0.05$ , \*\*\*  $p < 0.01$

Table B.1.

*Static model. summary statistics – Year 1800*

Variable	Mean	Std. Dev.	Min.	Max.	N
Population size estimate	800.014	1346.472	46	13021	287
Temperature estimate (Celsius)	12.16	1.862	6.189	15.978	287
Forest vs. Pasture	3.163	4.882	0	60.175	286
Commons vs. Private Land	17.783	38.402	0	520.074	287
Commons above the median (dummy)	0.526	0.5	0	1	287
Distance from local town (Km)	7.091	5.784	0	26	287
Altitude difference from local town (mts)	166.449	243.819	-325	962	287



Table B.2.

*Institutional choice*

	1350	1450	1550	1650	1750	1800
Population size estimate	<b>1.863***</b> (2.68)	<b>1.696***</b> (3.83)	<b>3.154***</b> (3.90)	<b>5.363***</b> (2.81)	<b>4.871***</b> (2.68)	<b>4.329**</b> (2.53)
Temperature estimate (Celsius)	3.878** (2.23)	0.646 (0.52)	-1.081 (-1.46)	-1.530** (-2.30)	-1.494** (-2.12)	-2.018*** (-2.74)
Forest vs. Pasture	0.720* (1.80)	0.511 (1.46)	0.058 (0.19)	0.060 (0.19)	-0.131 (-0.46)	-0.195 (-0.64)
Commons vs. Private Land	1.659 (1.43)	0.551 (1.46)	0.059 (0.21)	0.196 (0.73)	0.245 (0.88)	0.235 (0.79)
Commons above the median (dummy)	3.496*** (2.89)	1.677*** (2.59)	0.454 (1.14)	0.294 (0.68)	0.300 (0.69)	0.332 (0.78)
Distance from local town (Km)	-1.467 (-1.63)	-0.425 (-0.81)	-0.171 (-0.47)	-0.402 (-1.07)	-0.430 (-1.09)	-0.375 (-0.96)
Altitude difference from local town (mts)	2.774** (1.99)	0.692 (0.78)	-0.950 (-1.61)	-1.445*** (-2.60)	-1.312** (-2.26)	-1.445** (-2.34)
Observations	166	212	239	268	278	286
Log-likelihood	-49.75	-88.37	-130.1	-141.6	-142.6	-144.3
Area Fixed Effects	YES	YES	YES	YES	YES	YES

Logit regression, standardized coefficients. Robust standard errors in parentheses.

Significance levels: \*  $p < 0.10$ , \*\*  $p < 0.05$ , \*\*\*  $p < 0.01$

Table B.3.

*Institutional choice: having a charter when pasture is prevalent*

	1350	1450	1550	1650	1750	1800
Population size estimate	<b>3.144*</b> (1.65)	<b>1.881**</b> (2.35)	<b>1.866*</b> (1.76)	<b>1.652</b> (0.91)	<b>1.636</b> (0.97)	<b>1.411</b> (0.95)
Temperature estimate (Celsius)	1.305 (0.74)	-0.039 (-0.02)	-0.733 (-0.41)	-2.161 (-1.09)	-1.051 (-0.55)	-2.022 (-1.29)
Forest vs. Pasture	1.072 (1.05)	0.404 (0.51)	0.313 (0.47)	0.064 (0.09)	0.471 (0.68)	0.627 (0.92)
Commons vs. Private Land	1.315 (1.58)	0.770 (1.28)	-0.248 (-0.54)	-0.057 (-0.13)	0.036 (0.07)	0.214 (0.46)
Distance from local town (Km)	0.097 (0.06)	-0.435 (-0.46)	-0.939 (-1.45)	-0.708 (-1.11)	-1.298* (-1.84)	-0.928 (-1.44)
Altitude difference from local town (mts)	0.953 (0.40)	0.451 (0.22)	0.242 (0.15)	-1.979 (-1.12)	-1.100 (-0.68)	-1.928 (-1.56)
Observations	40	83	88	96	95	101
Log-likelihood	-17.92	-37.50	-46.37	-48.75	-46.96	-50.54
Area Fixed Effects	YES	YES	YES	YES	YES	YES

Logit regression, standardized coefficients. Robust standard errors in parentheses.

Significance levels: \*  $p < 0.10$ , \*\*  $p < 0.05$ , \*\*\*  $p < 0.01$

Table B.4.

*Institutional choice: having a charter when forest is prevalent*

	1350	1450	1550	1650	1750	1800
Population size estimate	<b>5.730**</b> (2.40)	<b>1.815*</b> (1.67)	<b>2.243**</b> (2.05)	<b>3.799**</b> (2.05)	<b>3.863**</b> (2.06)	<b>4.298**</b> (1.98)
Temperature estimate (Celsius)	4.059** (2.00)	2.132 (1.39)	0.514 (0.40)	-1.217 (-1.03)	-1.616 (-1.48)	-2.519** (-2.06)
Forest vs. Pasture	0.900 (1.36)	0.476 (0.77)	-0.016 (-0.03)	0.168 (0.26)	-0.327 (-0.65)	-0.265 (-0.51)
Commons vs. Private Land	2.568** (2.00)	0.485 (0.67)	0.244 (0.45)	0.104 (0.20)	0.155 (0.31)	0.537 (0.98)
Commons above the median (dummy)	1.183 (0.74)	1.871* (1.76)	-0.302 (-0.43)	0.098 (0.12)	-0.269 (-0.34)	-0.478 (-0.57)
Distance from local town (Km)	-3.486* (-1.83)	0.954 (0.84)	0.296 (0.41)	-0.176 (-0.25)	-0.277 (-0.44)	-0.073 (-0.11)
Altitude difference from local town (mts)	5.581*** (3.13)	2.692*** (2.75)	-0.514 (-0.48)	-1.411 (-1.41)	-1.731* (-1.66)	-2.003* (-1.74)
Observations	53	56	79	89	98	99
Log-likelihood	-13.87	-22.90	-45.11	-50.07	-53.95	-53.20
Area Fixed Effects	YES	YES	YES	YES	YES	YES

Logit regression, standardized coefficients. Robust standard errors in parentheses.

Significance levels: \*  $p < 0.10$ , \*\*  $p < 0.05$ , \*\*\*  $p < 0.01$

Table B.5.

*Event history model: risk of adopting a charter in 1200–1800*

	Pasture is Prevalent		Forest is Prevalent	
	(1)	(2)	(3)	(4)
<i>Group Size</i>				
Population size estimate	<b>0.000613***</b> (0.000)	<b>0.000600***</b> (0.000)	<b>0.000340**</b> (0.000)	<b>0.000360**</b> (0.000)
<i>Climate and Environment</i>				
Temperature estimate above the 3rd quartile	-1.093*** (0.308)	-1.125*** (0.310)	-0.705* (0.387)	-0.707* (0.385)
Forest vs. Pasture	-0.0132 (0.015)	-0.0130 (0.015)	-0.187 (0.192)	-0.183 (0.192)
Commons vs. Private Land	0.220*** (0.072)	0.210*** (0.067)	0.00682 (0.056)	0.00781 (0.056)
Commons above the median (dummy)	0.151 (0.278)	0.161 (0.278)	-0.222 (0.255)	-0.238 (0.254)
Altitude (mts a.s.l.)	-0.00301*** (0.001)	-0.00302*** (0.001)	-0.00188*** (0.000)	-0.00189*** (0.000)
<i>Remoteness</i>				
Distance from local town (Km)	-0.0429 (0.033)	-0.0425 (0.033)	-0.0351 (0.022)	-0.0348 (0.022)
Altitude difference from local town (mts)	0.000684 (0.001)	0.000659 (0.001)	0.00105 (0.001)	0.00105 (0.001)
<i>Regional Scale Shocks</i>				
Black Death (1348)	0.794 (0.519)		-1.008* (0.520)	
Peasant War (1525)	-0.800 (0.680)		-0.227 (0.742)	
Council of Trent (1546-1565)	-0.840 (0.778)		-1.179* (0.619)	
Crisis Mid-1600	0.215 (0.665)		1.673 (1.105)	
Age of Maria Theresa (1740-1795)	0.0180 (0.682)		-0.880 (0.723)	
Double Taxation (1407)	-0.425 (0.639)		-0.953 (0.983)	
"Landlibell" (1511)	0.454 (0.463)		-0.731 (0.498)	
Observations	6520	6520	7568	7568
Log-likelihood	-435.2	-438.1	-536.8	-546.1
Clusters (Communities)	131	131	154	154
Area Fixed Effects	NO	NO	NO	NO
Century Fixed Effects	YES	YES	YES	YES

Dependent variable: adoption of a charter by the community in the time interval  $[t, t-5]$ . Discrete time event history (proportional hazard) model, logit regression, non-parametric baseline hazard function (6 century dummies, no dummy for 1800), (Allison, 1984; Jenkins, 2004). Robust standard errors clustered per community. The constant term is suppressed as I use a fully non-parametric hazard baseline. The period covered is 1200-1800 (gap of 5 years, the period is estimated using the last year in each period: 1205 stands for 1200-1205, 1800 stands for 1795-1800). The model deals also with left truncation of observations from 1000-1200, considering communities already existent before 1200 as *delayed entry* (Jenkins, 2004). We used the methodology suggested by Cohen and Cohen (2003) for missing values in population size estimate: we set population to 0 and included among the regressors a dummy indicating missing values. The coefficients of this dummy are not inserted in the table. Correlations above  $\rho=0.5$ : *Altitude vs. Temperature above the 3rd quartile* ( $\rho=-0.66$ ), *Dummy 1300 vs. Black Death* ( $\rho=0.59$ ) and *Dummy 1600 vs. Crisis Mid-1600* ( $\rho=0.68$ ), no multicollinearity detected. Source: expanded panel, produced by the Author. Significance levels: \*  $p < 0.10$ , \*\*  $p < 0.05$ , \*\*\*  $p < 0.01$

Table S.1.

*Population estimates 1350–1800*

<b>Summary statistics for all communities: samples</b>					
<b>Year</b>	<b>Obs.</b>	<b>min</b>	<b>Median</b>	<b>Max</b>	<b>IQR</b>
1350	197	24	233	3,710	319
1450	218	22	211	3,836	323
1550	248	29	262	6,074	428.5
1650	269	29	260	8,273	406
1750	279	39	359	11,150	548
1800	287	46	414	13,021	601

Obs=1498. Frequency, minimum, median, maximum and IQR for population estimates of each community in each of the selected dates. The number of communities indicated in N takes into account fission-fusion dynamics as documented in original documents, and disregards missing values in population estimates (1350=8, 1450=10, 1550=12, 1650=12, 1750=12, 1800=12, Total=66). Source: Author's estimates on reduced panel.

Table S.2.

*Assembly size: face-to-face meetings of group members (1296–1796)*

<b>Unit of obs.</b>	<b>Sample</b>	<b>Obs.</b>	<b>Median</b>	<b>IQR</b>	<b>min</b>	<b>Max</b>	<b>Period</b>
Village	2	40	25	24	2	135	1364-1796
Stand-Alone (first)	4	23	20	23	8	54	1377-1785
Stand-Alone (last)	4	29	32	34	8	70	1524-1785
Cluster	3	1	33	0	33	33	1586
Multi-village	1	13	21	52	5	281	1296-1731

Table S.3.

*Plenary meetings, last institutional change: detail*

Unit of obs.		Freq.	Percent
Village level	Single village assembly	200	97.56
Cluster level	Livo, Preghena, Scanna	3	1.46
	Bresimo, Cis	2	0.98
<b>Total</b>		<b>205</b>	<b>100</b>

Table S.4.

*Plenary meetings, first institutional change: detail*

Unit of obs.		Freq.	Percent
Village level	Single village assembly	195	95.12
Multi-village level	Cogolo, Celledizzo	2	0.98
	Condino, Brione	2	0.98
	Romeno, don, Amblar	3	1.46
	Coredo, Smarano, Sfruz	3	1.46
<b>Total</b>		<b>205</b>	<b>100</b>

Table S.5.

*Summary statistics: institutions (full charters)*

Variable	Mean	Std. Dev.	Min.	Max.	N
Governance	8.353	8.212	0	54	153
Participation	2.216	2.256	0	10	153
Constraints on outsiders	5.477	5.424	0	30	153
Resource Management	33.49	22.294	0	125	153
Governance (frac.)	0.171	0.145	0	0.700	153
Participation (frac.)	0.052	0.097	0	1	153
Constraints on outsiders (frac.)	0.12	0.124	0	1	153
Resource Management (frac.)	0.658	0.196	0	1	153
Year of the assembly	1593.952	126.933	1296	1796	165
Document Length	50.222	30.067	2	151	162
Number of roles in each assembly	3.533	1.599	1	7	165
Forward stability of the institution	203.018	128.079	1	511	165
Forward stability of the institution (Until Next Change)	121.116	93.922	1	376	43
Forward stability of the institution (Right-Censored at 1807)	231.885	126.285	11	511	122

Table S.6.

*Summary statistics: institutions (modifications and other)*

Variable	Mean	Std. Dev.	Min.	Max.	N
Governance	2.413	4.331	0	17	75
Participation	0.507	0.991	0	4	75
Constraints on outsiders	1.693	2.504	0	13	75
Resource Management	9.493	17.231	0	112	71
Governance (frac.)	0.134	0.236	0	1	71
Participation (frac.)	0.043	0.115	0	0.8	71
Constraints on outsiders (frac.)	0.201	0.28	0	1	71
Resource Management (frac.)	0.622	0.336	0	1	71
Year of the assembly	1650.441	110.571	1249	1801	93
Document Length	12.877	20.639	1	121	81
Number of roles in each assembly	3.667	1.462	1	7	93
Forward stability of the institution	157.957	108.548	6	558	93
Forward stability of the institution (Until Next Change)	184.579	46.619	88	301	19
Forward stability of the institution (Right-Censored at 1807)	151.122	118.667	6	558	74

## APPENDIX E: CASE HISTORIES

In this appendix, a detailed account of multi-village organization is provided in tabular and graphical form. For ease of reading, a legend of the statistics reported in each table is provided below:

Variable Description	
<i>Variable Description</i>	<i>Type</i>
Assembly ID	Raw, numeric
Year of the assembly.	Raw, numeric
List of government rules (articles).	Coded, string
List of participation rules (articles).	Coded, string
List of constraints on outsiders (articles).	Coded, string
Sum of the articles decided in the observed assembly.	Count, numeric
Cumulative sum of the articles until the closest complete charter.	Count, sum
Number of government rules	Count, numeric
Number of participation rules	Count, numeric
Number of constraints on outsiders rules	Count, numeric
Number of resource management rules.	Count, numeric
Source of the document (complete charter or change to charter).	Raw, string

*Source: Polity v7 (14Aug2012)*

The table of each case is divided into three parts: header, body, and statistics. The header contains the name of the multi-village organization and the following information: the years in which an institutional change has been detected, the fission or fusion event in each year (IC), and the internal structure of the multi-village organization in each year (L). The body contains information on the villages belonging to the multi-village organization: for each village, the estimated population for each village in each of the observation years is reported in the correspondent cell. The total population of the multi-village is computed. Shading indicates the start of an autonomous charter. When population is marked bold, this indicates that an institutional change occurred with that village (the first for adoption, the following for renewal). Cell borders are used to indicate whether a village is independent or whether more villages are considered as sharing a common organization. The statistics section contains relevant statistics at the village and cluster levels.

A visual profile for the population of each village follows for each multi-village organization.

Particular cases of multi-village organizations are described in detail below the respective table:

1. Valle di Fiemme
2. Comun Comunale
3. Pergine

If a description is not provided, it means that the organization is either horizontal, or that it was not possible to obtain the description of the formalized organization directly from the documents.

<b>GIOVO, FAEDO</b>	<b>Year</b>			
<b>Population in:</b>	<b>1400</b>	<b>1646</b>	<b>1680</b>	<b>1757</b>
<b>IC</b>	Individual Adoption	Fusion	Fission Coexistence	Renewal
<b>L</b>	V	MV	MV	MV
Faedo	<b>169</b>	247	<b>268</b>	334
Giovo	417	609	658	821
<b>Total</b>	586	<b>856</b>	926	<b>1155</b>
<u>By Village:</u>				
<i>N</i>	2	2	2	2
<i>Pop. largest village</i>	417	609	658	821
<i>% largest village (M)</i>	0.71	0.71	0.71	0.71
<i>% largest village (C)</i>	293	428	463	577.5
<i>Total pop./N</i>	293	428	463	577.5
<u>By Cluster:</u>				
<i>N</i>				
<i>Pop. largest cluster</i>				
<i>% largest cluster (M)</i>				
<i>Cluster pop./N</i>				

Notes: no data on cluster structure. All separate village assemblies

<b>QUATTRO VICARIATI</b>	<b>Year</b>					
<b>Population in:</b>	<b>1300</b>	<b>1411</b>	<b>1440</b>	<b>1565</b>	<b>1616</b>	<b>1619</b>
<b>IC</b>	Individual Adoption	Individual Adoption	Individual Adoption	Renewal	Individual Adoption	Fusion
<b>L</b>	V	V	V	V	V	MV
Ala	<b>692</b>	<b>1496</b>	1584	<b>2219</b>	2339	2305
Avio	0	1520	<b>1609</b>	2254	2376	2342
Brentonico	636	<b>1372</b>	1453	2037	2146	2116
Mori	687	1483	1570	2200	<b>2319</b>	2285
<b>Total</b>	2015	5871	6216	8710	9180	<b>9048</b>
<u>By Village:</u>						
<i>N</i>	3	4	4	4	4	4
<i>Pop. largest village</i>	692	1520	1609	2254	2376	2342
<i>% largest village (M)</i>	0.343654	0.258862	0.258812	0.258783	0.258799	0.258842
<i>% largest village (C)</i>	n.a.	n.a.	n.a.	n.a.	n.a.	n.a.
<i>Total pop./N</i>	671.6667	1467.75	1554	2177.5	2295	2262
<u>By Cluster:</u>						
<i>N</i>						
<i>Pop. largest cluster</i>						
<i>% largest cluster (M)</i>						
<i>Cluster pop./N</i>						

Note. No data on cluster structure. All separate village assemblies.



RONCONE, LARDARO	Year			
	1500	1702	1761	1793
Population in:				
IC	Fusion	Fission Independence	Renewal	Fission Independence
L	MV	V	V	V
Lardaro	112	150	179	<b>200</b>
Ronccone	553	<b>741</b>	<b>885</b>	986
<b>Total</b>	<b>665</b>	891	1064	1186
<u>By Village:</u>				
<i>N</i>	2	2	2	2
<i>Pop. largest village</i>	553	741	885	986
<i>% largest village (M)</i>	0.831579	0.83165	0.830986	0.831366
<i>% largest village (C)</i>	n.a.	n.a.	n.a.	n.a.
<i>Total pop./N</i>	332.5	445.5	532	593
<u>By Cluster:</u>				
<i>N</i>				
<i>Pop. largest cluster</i>				
<i>% largest cluster (M)</i>				
<i>Cluster pop./N</i>				

Note. No data on cluster structure. All separate village assemblies.

TELVE DI SOPRA	Year	
	1296	1648
IC	Fusion	Fission Coexistence
L	MV	MV
Carzano	297	174
Ronchi	0	0
Telve di sopra	387	<b>227</b>
Torcegno	0	319
<b>Total</b>	<b>684</b>	720
<u>By Village:</u>		
<i>N</i>	2	3
<i>Pop. largest village</i>	387	319
<i>% largest village (M)</i>	0.565688	0.443055
<i>% largest village (C)</i>	n.a.	n.a.
<i>Total pop./N</i>	342	240
<u>By Cluster:</u>		
<i>N</i>		
<i>Pop. largest cluster</i>		
<i>% largest cluster (M)</i>		
<i>Cluster pop./N</i>		

Note. All separate village assemblies.

<b>BRESIMO</b>	<b>Year</b>				
<b>Population in:</b>	<b>1309</b>	<b>1391</b>	<b>1587</b>	<b>1603</b>	<b>1671</b>
<b>IC</b>	Fusion	Fission Coexistence	Fission Coexistence	Renewal	Renewal
<b>L</b>	MV	MV	MV	MV	MCV
Livo	148	102	157	161	151
Preghena	135	93	143	147	137
Scanna, Cassino	0	<b>49</b>	75	77	72
Bresimo	136	94	144	148	138
Cis	135	93	<b>143</b>	147	137
<b>Total</b>	<b>554</b>	431	662	<b>680</b>	<b>635</b>
<i>Livo, Preghena (*)</i>					<b>360</b>
<i>Bresimo, Cis</i>					276
<u>By Village:</u>					
<i>N</i>	4	5	5	5	5
<i>Pop. largest village</i>	148	102	157	161	151
<i>% largest village (M)</i>	0.266923	0.237591	0.237043	0.236351	0.237369
<i>% largest village (C)</i>	n.a.	n.a.	n.a.	n.a.	0.501624
<i>Total pop./N</i>	138.5	86.2	132.4	136	127
<u>By Cluster:</u>					
<i>N</i>					2
<i>Pop. largest cluster</i>					360
<i>% largest cluster (M)</i>					0.566423
<i>Cluster pop./N</i>					

Note. The documents report a division in 1722, without specifying the villages, nor the resources involved. This change is reported in the chart on fission–fusion in the paper but not observed here.

Note 2. Presence of face-to-face plenary assemblies at multi-village level at the last institutional change.

(\*) Livo, Preghena, Scanna are compound another: Mezzalone. First charter in 1504, last 1671. The first charter is not recorded here, but is considered in the dataset.

REVO'	Year					
Population in:	1320	1550	1587	1598	1611	1633
IC	Fusion	Fission Coexistence	Fission Coexistence	Fission Coexistence	Fission Coexistence	Fission Clustering
L	MV	MV	MV	MV	MV+	MCV+
Romallo	0	369	407	423	412	384
Cagno'	245	195	215	224	218	202
Revò	918	734	809	841	818	761
Cloz	595	475	525	546	530	494
Lauregno	0	249	274	285	278	258
Proves	0	185	204	212	206	192
Rumo (*)	781	624	689	716	696	648
<b>Total</b>	<b>2539</b>	2831	3123	3247	3158	<b>2939</b>
<i>Romallo, Cagno, Revo</i>						1347
<i>Cloz, Lauregno, Proves, Rumo</i>						1593
<u>By Village:</u>						
<i>N</i>	4	7	7	7	7	7
<i>Pop. largest village</i>	918	734	809	841	818	761
<i>% largest village (M)</i>	0.361548	0.25901	0.258974	0.258939	0.25879	0.258944
<i>% largest village (C)</i>	n.a.	n.a.	n.a.	n.a.	n.a.	0.565055
<i>Total pop./N</i>	634.75	404.4286	446.1429	463.8571	451.1429	419.8571
<u>By Cluster:</u>						
<i>N</i>						2
<i>Pop. largest cluster</i>						1593
<i>% largest cluster (M)</i>						0.541737
<i>Cluster pop./N</i>						1469.5

Note 1. (\*) After 1611, Rumo is part of a multi-village community, coordinating with the following seven villages: Marcena, Mione, Mocenigo, Corte Superiore, Corte Inferiore, Alzenigo, Lanza (Giacomoni, II, 445). None has a charter, and no 1810 census data is available.

Note 2. All separate village assemblies.

<b>CONDINO, BRIONE</b>	<b>Year</b>						
<b>Population in:</b>	<b>1324</b>	<b>1341</b>	<b>1389</b>	<b>1504</b>	<b>1566</b>	<b>1721</b>	<b>1751</b>
<b>IC</b>	Fusion	Renewal	Renewal	Fission Coexistence	Renewal	Renewal	Renewal
<b>L</b>	MV	MV	MV	MV	MV	MV	MV
Brione	98	94	79	<b>97</b>	116	<b>136</b>	<b>149</b>
Condino	473	452	383	469	559	657	715
<b>Total</b>	<b>571</b>	<b>546</b>	<b>462</b>	<b>566</b>	<b>675</b>	793	864
<u>By Village:</u>							
<i>N</i>	2	2	2	2	2	2	2
<i>Pop. largest village</i>	473	452	383	469	559	657	715
<i>% largest village (M)</i>	0.828371	0.827839	0.827214	0.828622	0.828148	0.827456	0.827546
<i>% largest village (C)</i>	n.a.	n.a.	n.a.	n.a.	n.a.	n.a.	n.a.
<i>Total pop./N</i>	285.5	273	231	283	337.5	396.5	432
<u>By Cluster:</u>							
<i>N</i>							
<i>Pop. largest cluster</i>							
<i>% largest cluster (M)</i>							
<i>Cluster pop./N</i>							

Note. All separate village assemblies.

<b>PINE</b>	<b>Year</b>				
<b>Population in:</b>	<b>1388</b>	<b>1430</b>	<b>1465</b>	<b>1498</b>	<b>1764</b>
<b>IC</b>	Fusion	Renewal	Renewal	Renewal	Fission Coexistence
<b>L</b>	MV	MV	MV	MV	MV
Baselga	663	678	732	799	670
Bedollo	0	0	0	0	684
Fornace	496	507	548	598	<b>501</b>
Lona-Lases	290	295	319	348	292
Miola	0	0	0	0	693
<b>Total</b>	<b>1449</b>	<b>1480</b>	<b>1599</b>	<b>1745</b>	2840
<u>By Village:</u>					
<i>N</i>	3	3	3	3	5
<i>Pop. largest village</i>	663	678	732	799	693
<i>% largest village (M)</i>	0.457669	0.457817	0.457855	0.457651	0.244014
<i>% largest village (C)</i>	n.a.	n.a.	n.a.	n.a.	n.a.
<i>Total pop./N</i>	483	493.3333	533	581.6667	568
<u>By Cluster:</u>					
<i>N</i>					
<i>Pop. largest cluster</i>					
<i>% largest cluster (M)</i>					
<i>Cluster pop./N</i>					

Note: separate village assemblies.

<b>COREDO, SMARANO, SFRUZ</b>	<b>Year</b>				
<b>Population in:</b>	<b>1437</b>	<b>1483</b>	<b>1581</b>	<b>1582</b>	<b>1696</b>
<b>IC</b>	Fusion	Fission Coexistence	Fission Clustering	Fission Independence	Fission Independence
<b>L</b>	MV	MV	MCV	MCV	V
Smarano	169	<b>190</b>	249	249	<b>261</b>
Sfruz	210	237	310	310	324
Coredo	380	428	<b>561</b>	<b>561</b>	587
<b>Total</b>	<b>759</b>	<b>855</b>	1120	1120	1172
<i>Smarano, Sfruz</i>			<b>559</b>	559	
<i>Coredo</i>			<i>561</i>	<i>561</i>	
<b>By Village:</b>					
<i>N</i>	3	3	3	3	3
<i>Pop. largest village</i>	380	428	561	561	587
<i>% largest village (M)</i>	0.50	0.50	0.50	0.50	0.50
<i>% largest village (C)</i>	n.a.	n.a.	n.a.	n.a.	n.a.
<i>Total pop./N</i>	253	285	373	373	390
<b>By Cluster:</b>					
<i>N</i>			2	2	
<i>Pop. largest cluster</i>			561	561	
<i>% largest cluster (M)</i>			0.50	0.50	
<i>Cluster pop./N</i>			560	560	

Presence of face-to-face plenary assemblies at the multi-village level (first), and at the cluster level (1581, 1582).

<b>ROMENO, DON AMBLAR</b>	<b>Year</b>			
<b>Population in:</b>	<b>1459</b>	<b>1493</b>	<b>1691</b>	<b>1694</b>
<b>IC</b>	Fusion	Fission Independence	Fission Independence	Renewal
<b>L</b>	MV	MCV	V	V
Don	112	123	162	164
Amblar	95	104	<b>138</b>	140
Romeno	266	<b>290</b>	383	<b>389</b>
<b>Total</b>	<b>473</b>	<b>517</b>	683	693
<i>Don, Amblar</i>		227		
<i>Romeno</i>		290		
<b>By Village:</b>				
<i>N</i>	3	3	3	3
<i>Pop. largest village</i>	266	290	383	389
<i>% largest village (M)</i>	0.561181	0.558767	0.559942	0.560519
<i>% largest village (C)</i>	n.a.	1	n.a.	n.a.
<i>Total pop./N</i>	157.6667	172.3333	227.6667	231
<b>By Cluster:</b>				
<i>N</i>		2		
<i>Pop. largest cluster</i>		290		
<i>% largest cluster (M)</i>		0.558767		
<i>Cluster pop./N</i>		258.5		

Note: presence of face-to-face plenary assemblies at cluster level in 1493.

<b>SAN SISINIO</b>	<b>Year</b>				
<b>Population in:</b>	<b>1492</b>	<b>1551</b>	<b>1586</b>	<b>1632</b>	<b>1728</b>
<b>IC</b>	Individual Adoption	Individual Adoption	Fusion	Fission Clustering	Fission Clustering
<b>L</b>	MV	MV	MV	MCV	MCV
Sanzeno	115	<b>137</b>	<b>151</b>	145	174
Salter-Malgolo	135	160	<b>177</b>	169	203
Tavon	<b>86</b>	102	113	108	129
Banco	112	133	147	141	<b>169</b>
Casez	135	160	177	<b>169</b>	203
<b>Total</b>	583	692	<b>765</b>	732	878
<i>Sanzeno, Salter-Malgolo, Tavon</i>				422	506
<i>Banco, Casez</i>				310	372
<b><u>By Village:</u></b>					
<i>N</i>	5	5	5	5	5
<i>Pop. largest village</i>	135	160	177	169	203
<i>% largest village (M)</i>	0.230769	0.229885	0.230769	0.230559	0.230944
<i>% largest village (C)</i>	n.a.	n.a.	n.a.	1	0.545699
<i>Total pop./N</i>	116.6	138.4	153	146.4	175.6
<b><u>By Cluster:</u></b>					
<i>N</i>				2	2
<i>Pop. largest cluster</i>				563	506
<i>% largest cluster (M)</i>				0.575716	0.575654
<i>Cluster pop./N</i>				366	439

Note. All separate village assemblies.

TELVANA	Year			
	1267	1574	1595	1631
<b>Population in:</b>				
<b>IC</b>	Fusion	Renewal	Fission Clustering	Fission Clustering
<b>L</b>	MV	MV	MCV	MCV
Castelnuovo	312	374	395	367
Novaledo	238	286	302	281
Telve	617	740	781	727
Roncegno	988	1186	1250	<b>1164</b>
Borgo Valsugana	1621	1946	<b>2053</b>	1910
<b>Total</b>	<b>3776</b>	<b>4532</b>	<b>4781</b>	<b>4449</b>
<i>Castelnuovo, Novaledo, Telve</i>			1478	1376
<i>Borgo Valsugana, Roncegno</i>			2053	3073
<b>By Village:</b>				
<i>N</i>	5	5	5	5
<i>Pop. largest village</i>	1621	1946	2053	1910
<i>% largest village (M)</i>	0.429222	0.429346	0.429309	0.429292
<i>% largest village (C)</i>	n.a.	n.a.	1	0.621419
<i>Total pop./N</i>	755.2	906.4	956.2	889.8
<b>By Cluster:</b>				
<i>N</i>			2	2
<i>Pop. largest cluster</i>			2728	3073
<i>% largest cluster (M)</i>			0.429309	0.690825
<i>Cluster pop./N</i>			2390.5	2224.5

Note. Telvana is a jurisdiction. All separate village assemblies.

MALOSCO		Year							
Population in:	1469	1578	1582	1586	1587	1593	1616	1624	1746
IC	Individual Adoption	Fusion	Fission Clustering	Fission Clustering	Fission Coexistence	Renewal	Fission Coexistence	Fission Coexistence	Renewal
L	V	MV	MCV	MCV	MV	MV	MV	MV	MV
Ronzone	160	160	<b>191</b>	<b>191</b>	194	199	193	<b>188</b>	231
Sarnonico	156	156	<b>186</b>	<b>186</b>	<b>189</b>	194	188	183	225
Malosco	<b>178</b>	178	213	213	217	222	215	210	258
Seio	0	0	81	81	82	84	<b>82</b>	80	98
<b>Total</b>	494	<b>494</b>	671	671	682	<b>699</b>	678	661	<b>812</b>
<i>Ronzone, Sarnonico</i>			<b>378</b>	<b>378</b>					
<i>Malosco, Seio</i>			294	294					
<u>By Village:</u>									
<i>N</i>	3	3	4	4	4	4	4	4	4
<i>Pop. largest village</i>	178	178	213	213	217	222	215	210	258
<i>% largest village (M)</i>	0.361132	0.361132	0.317437	0.317437	0.318113	0.317528	0.31711	0.317629	0.317734
<i>% largest village (C)</i>	n.a.	n.a.	0.724488	0.724488	n.a.	n.a.	n.a.	n.a.	n.a.
<i>Total pop./N</i>	164.6667	164.6667	167.75	167.75	170.5	174.75	169.5	165.25	203
<u>By Cluster:</u>									
<i>N</i>			2	2					
<i>Pop. largest cluster</i>			378	378					
<i>% largest cluster (M)</i>			0.561847	0.561847					
<i>Cluster pop./N</i>			335.5	335.5					

Note. The organization of Malosco is horizontal, and the assemblies were held in Malosco. All separate village assemblies.



COMMEZZADURA	Year	
	1494	1731
Population in:	IC	Fusion
	Individual Adoption	
	L	MV
Almazago	72	107
Deggiano	100	149
Mastellina	74	110
Piano	102	151
<b>Total</b>	348	<b>517</b>
<u>By Village:</u>		
<i>N</i>	4	4
<i>Pop. largest village</i>	102	151
<i>% largest village (M)</i>	0.292404	0.29233
<i>% largest village (C)</i>	n.a.	n.a.
<i>Total pop./N</i>	87	129.25
<u>By Cluster:</u>		
<i>N</i>		
<i>Pop. largest cluster</i>		
<i>% largest cluster (M)</i>		
<i>Cluster pop./N</i>		

Note. The organization of Commezzadura is horizontal, all separate village assemblies.

COMUN COMUNALE	Year											
	1492	1544	1611	1656	1662	1750	1753	1759	1768	1786	1796	
Population in:	IC	Fusion	Renewal	Fission Clustering	Fission Coexistence	Fission Coexistence	Fission Coexistence	Renewal	Fission Coexistence	Fission Coexistence	Fission Coexistence	Fission Coexistence
L	MV	MV	MCV	MCV	MCV	MCV	MCV	MCV	MCV	MCV	MCV	MCV
Aldeno	0	752	850	751	<b>762</b>	994	<b>1011</b>	1027	1061	1111	1144	
Castellano	508	500	565	499	508	662	673	684	706	739	761	
Cimone	406	399	451	398	404	529	537	546	<b>563</b>	590	607	
Isera	379	373	422	<b>372</b>	<b>379</b>	<b>494</b>	<b>503</b>	<b>511</b>	<b>527</b>	<b>552</b>	<b>569</b>	
Marano	159	157	177	157	159	207	211	214	222	232	<b>239</b>	
Nomi	762	749	847	748	761	992	1009	1025	1058	1109	1142	
Pederzano	421	414	468	413	420	548	557	567	585	612	631	
Villa Lagarina	413	406	459	406	412	537	547	<b>556</b>	<b>574</b>	<b>601</b>	<b>619</b>	
Brancolino	0	114	129	113	115	150	153	155	160	168	173	
Folas-Revian	86	83	95	84	85	111	113	115	118	125	128	
Sasso	0	0	0	123	126	164	166	170	175	184	189	
Noarna	152	149	169	149	152	<b>197</b>	<b>201</b>	<b>205</b>	<b>211</b>	<b>221</b>	<b>228</b>	
Piazzo	0	0	0	0	0	0	0	0	0	<b>0</b>	<b>0</b>	
Pomarolo	698	686	777	685	696	909	924	939	970	1015	1046	
Savignano	223	220	248	219	223	291	296	301	310	325	335	
Nogaredo	364	358	405	358	364	474	482	490	506	530	546	
<b>Total</b>	<b>4571</b>	<b>5360</b>	<b>6062</b>	<b>5475</b>	<b>5566</b>	<b>7259</b>	<b>7383</b>	<b>7505</b>	<b>7746</b>	<b>8114</b>	<b>8357</b>	
<i>Aldeno, Castellano, Cimone, Isera, [...]</i>			<i>4644</i>	<i>3351</i>	<i>4168</i>	<i>5438</i>	<i>5529</i>	<i>5620</i>	<i>5803</i>	<i>6076</i>	<i>6259</i>	
<i>Brancolino, Folas-Revian</i>			<i>223</i>	<i>197</i>	<i>200</i>	<i>261</i>	<i>266</i>	<i>270</i>	<i>279</i>	<i>292</i>	<i>301</i>	
<i>Sasso, Noarna</i>			<i>169</i>	<i>273</i>	<i>227</i>	<i>361</i>	<i>367</i>	<i>375</i>	<i>386</i>	<i>404</i>	<i>417</i>	
<i>Piazzo, Savignano, Pomarolo</i>			<i>1025</i>	<i>905</i>	<i>920</i>	<i>1200</i>	<i>1220</i>	<i>1239</i>	<i>1280</i>	<i>2485</i>	<i>1381</i>	
<u>By Village:</u>												
<i>N</i>	12	14	14	15	15	15	15	15	15	15	15	
<i>Pop. largest village</i>	762	752	850	751	762	994	1011	1027	1061	1111	1144	
<i>% largest village (M)</i>	0.16 672	0.14 0246	0.14 0176	0.13 7056	0.13 6899	0.13 6946	0.13 6988	0.13 6912	0.13 6916	0.13 6957	0.13 6942	
<i>% largest village (C)</i>	n.a.	n.a.	1.00 005	0.75 7307	0.75 7054	0.75 7728	0.75 7296	0.75 7691	0.75 7546	0.57 436	0.75 7365	
<i>Total pop./N</i>	380. 9167	382. 8571	433	365	371. 0667	483. 9333	492. 2	500. 3333	516. 4	540. 9333	557. 1333	
<u>By Cluster:</u>												
<i>N</i>			4	4	4	4	4	4	4	4	4	
<i>Pop. largest cluster</i>			4644	3351	4168	5438	5529	5620	5803	6076	6259	
<i>% largest cluster (M)</i>			0.76 6161	0.61 1889	0.74 8958	0.74 8941	0.74 8955	0.74 8935	0.74 8993	0.74 8936	0.74 89	
<i>Cluster pop./N</i>			1515 .5	1368 .75	1391 .5	1814 .75	1845 .75	1876 .25	1936 .5	2028 .5	2089 .25	

Note. In the 1544 charter, four informal clusters are identified at the beginning: 1) Aldeno, Castellano, Cimone, Isera, Marano; 2) Brancolino, Folas-Revian; 3) Sasso, Noarna; 4) Piazzo, Savignano, Pomarolo. A short list of elected members from each cluster is provided, together with a list of three officers (massari) from Pomarolo and a list of nine mayors (three from Castronovo, three from Rovereto, and three from Nomi), which were “probos et discretos” (just and confidential). From the text, it is learned that only the representatives are sent to the multi-village level assembly. Thus, this case is interpreted as having multiple separate assemblies at the village level.

PIEVE DEL BANALE		Year								
Population in:	1300	1468	1469	1472	1570	1584	1593	1718	1749	1751
IC	Individual Adoption	Individual Adoption	Fusion + F. Clustering	Fission Coexistence	Fission Coexistence	Fission Coexistence	Fission Coexistence	Renewal	Renewal	Fission Coexistence
L	V	V	MCV	MCV	MCV	MCV	MCV	MCV	MCV	MCV
Andogno	0	65	65	65	86	<b>90</b>	92	100	109	109
S. Lorenzo in Banale	0	393	393	393	521	542	<b>557</b>	604	657	657
Dorsino	0	110	110	110	<b>146</b>	152	156	169	184	184
Sclemo	0	76	76	76	49	51	52	51	128	128
Premione	0	63	63	63	40	41	43	41	105	105
Stenico	<b>347</b>	293	293	<b>293</b>	189	197	201	194	<b>489</b>	489
Seo	0	0	0	0	0	0	0	50	129	<b>129</b>
Tavodo	0	<b>35</b>	35	35	23	24	24	24	59	59
Villa Banale	0	0	0	0	88	92	94	90	229	229
<b>Total</b>	347	1035	<b>1035</b>	1035	1142	1189	1219	1323	2089	2089
<i>Andogno, S. Lorenzo in Banale, Dorsino</i>		568	<b>568</b>	568	753	784	805	<b>873</b>	950	950
<i>Sclemo, Premione, Stenico, Seo, [...]</i>		347	467	<b>467</b>	467	388	404	414	450	1139
<u>By Village:</u>										
<i>N</i>	1	7	7	7	8	8	8	9	9	9
<i>Pop. largest village</i>	347	393	393	393	521	542	557	604	657	657
<i>% largest village (M)</i>	1	0.379 71	0.379 71	0.379 71	0.456 617	0.456 229	0.456 932	0.456 538	0.314 505	0.314 505
<i>% largest village (C)</i>	1	0.691 901	0.691 901	0.691 901	0.691 899	0.691 327	0.691 925	0.691 867	0.691 579	0.691 579
<i>Total pop./N</i>	347	147.8 571	147.8 571	147.8 571	142.7 5	148.6 25	152.3 75	147	232.1 111	232.1 111
<u>By Cluster:</u>										
<i>N</i>	1	2	2	2	2	2	2	2	2	2
<i>Pop. largest cluster</i>	347	568	568	568	753	784	805	873	1139	1139
<i>% largest cluster (M)</i>	1	0.548 792	0.548 792	0.548 792	0.659 947	0.659 933	0.660 377	0.659 864	0.545 237	0.545 237
<i>Cluster pop./N</i>	347	517.5	517.5	517.5	571	594.5	609.5	661.5	1044. 5	1044. 5

PERGINE	Year					
	1364	1401	1419	1516	1589	1780
Population in:	Individual Adoption	Fusion	Fission Coexistence	Renewal	Renewal	Fission Coexistence
IC	V	MV	MV	MV	MV	MV
L	V	MV	MV	MV	MV	MV
Canezza	0	0	0	0	0	333
Castagne	0	0	0	0	0	426
Costasavina	0	0	0	0	0	218
Falesina	0	0	0	0	0	0
Frassilongo	511	451	413	448	554	559
Ischia	0	0	0	0	0	470
Madrano	<b>326</b>	287	263	285	<b>353</b>	357
Nogare	0	0	0	0	0	289
Pergine	2177	1925	1760	1911	2363	2384
Roncogno	0	0	0	191	236	238
Serso	0	0	0	177	219	221
Susa-Canale	407	360	329	357	441	445
Tenna	0	0	0	265	327	<b>330</b>
Viarago	525	464	424	460	570	575
Vigalzano, Costa(Savina), [Casalino], etc.	0	0	<b>436</b>	474	<b>586</b>	592
Vignola	0	0	0	0	0	0
<b>Total</b>	3946	<b>3487</b>	3625	<b>4568</b>	5649	7437
<u>By Village:</u>						
<i>N</i>	5	5	6	9	9	14
<i>Pop. largest village</i>	2177	1925	1760	1911	2363	2384
<i>% largest village (M)</i>	0.55185 4	0.55194 1	0.48551	0.41830 5	0.41832 2	0.320555
<i>% largest village (C)</i>	n.a.	n.a.	n.a.	n.a.	n.a.	n.a.
<i>Total pop./N</i>	789.2	697.4	604.1667	507.555 6	627.666 7	531.2143
<u>By Cluster:</u>						
<i>N</i>						
<i>Pop. largest cluster</i>						
<i>% largest cluster (M)</i>						
<i>Cluster pop./N</i>						

Note. In 1516, the general assembly of Pergine had the following participation: one mayor per village, one captain and pievano (priest), one gastaldo, one massaro (officer) elected among those having the requirements. During the assembly, the general assembly, the general mayor, and the gastaldo were elected by the captain, and the regolano (head of the assembly) was elected by the attendants. In addition, 12 good and prudent men were elected in charge for a yearly appointment, together with several other charges. From the text of the charter, it is evident that the assembly was participated in by village representatives; therefore, this case was counted as separate unclustered village meetings.

<b>VAL DI GRESTA</b>	<b>Year</b>		
<b>Population in:</b>	<b>1678</b>	<b>1787</b>	<b>1789</b>
<b>IC</b>	Fusion	Fission Coexistence	Fission Coexistence
<b>L</b>	MV	MV	MV
Nomesino	0	0	0
Manzano	202	276	280
Chienis	310	424	<b>431</b>
Pannone	383	524	531
Ronzo	305	<b>419</b>	425
<b>Total</b>	<b>1200</b>	1643	1667
<i>Nomesino, Manzano, Chienis</i>		700	711
<i>Pannone, Ronzo</i>		943	956
<b>By Village:</b>			
<i>N</i>	4	4	4
<i>Pop. largest village</i>	383	524	531
<i>% largest village (M)</i>	0.319094	0.318685	0.318652
<i>% largest village (C)</i>	n.a.	1	0.654798
<i>Total pop./N</i>	300	410.75	416.75
<b>By Cluster:</b>			
<i>N</i>		2	2
<i>Pop. largest cluster</i>		943	956
<i>% largest cluster (M)</i>		0.57395	0.57348
<i>Cluster pop./N</i>		821.5	833.5

VAL DI LEDRO	Year					
	1435	1567	1590	1736	1781	1793
Population in:						
IC	Fusion	Renewal	Renewal	Fission Coexistence	Fission Coexistence	Renewal
L	MCV	MCV	MCV	MCV	MCV	MCV
Barcesino	69	85	75	68	78	81
Bezzecca	343	420	373	336	386	404
Biacesa	0	0	0	200	229	240
Concei (Locca, Lenzumo) Enguiso	0	0	454	409	469	490
Legos	302	369	328	295	339	355
Mezzolago	0	0	0	124	142	148
Molina	0	332	295	266	305	320
Pieve di Ledro	171	211	187	168	193	202
Pre	0	0	0	<b>217</b>	<b>249</b>	<b>261</b>
Pregasina	0	0	0	116	133	139
Tiarno di Sopra	397	487	433	390	447	468
Tiarno di Sotto	481	590	524	472	<b>542</b>	<b>566</b>
<b>Total</b>	<b>1763</b>	<b>2494</b>	<b>2669</b>	3061	3512	3674
<i>Tiarno di Sopra, Tiarno di Sotto</i>	878	1077	957	861	988	1034
<i>Barcesino, [...]</i>	885	1417	1712	2201	2525	2640
<u>By Village:</u>						
<i>N</i>	6	7	8	12	12	12
<i>Pop. largest village</i>	481	590	524	472	542	566
<i>% largest village (M)</i>	0.272812	0.236593	0.196246	0.154022	0.154219	0.154035
<i>% largest village (C)</i>	0.547577	0.547761	0.547465	0.547674	0.548125	0.547481
<i>Total pop./N</i>	293.8333	356.2857	333.625	255.0833	292.6667	306.1667
<u>By Cluster:</u>						
<i>N</i>	2	2	2	2	2	2
<i>Pop. largest cluster</i>	885	1417	1712	2201	2525	2640
<i>% largest cluster (M)</i>	0.501785	0.568072	0.641537	0.718771	0.718644	0.718648
<i>Cluster pop./N</i>	881.5	1247	1334.5	1530.5	1756	1837

VALLE DI FIEMME		Year								
Population in:	1304	1480	1533	1605	1608	1613	1615	1624	1776	1783
IC	Individual Adoption	Fusion + F. Clustering	Fission Coexistence	Renewal	Fission Coexistence	Renewal	Renewal	Fission Coexistence	Renewal	Fission Coexistence
L	v	MCV	MCV	MCV	MCV	MCV	MCV	MCV	MCV	MCV
Predazzo	0	962	1029	1196	<b>1179</b>	1163	<b>1163</b>	1130	<b>1454</b>	1499
Moena	1484	783	837	972	959	946	946	919	1184	1220
Dajano	0	134	143	166	164	161	161	157	202	208
Tesero	1335	704	754	875	863	851	851	828	1065	1098
Panchia'	0	0	0	0	0	0	0	0	395	<b>407</b>
Ziano	0	497	532	618	609	601	601	583	751	774
Cavalese	1633	861	921	1070	1055	1040	1040	<b>1011</b>	1302	1342
Forno	0	0	0	108	106	105	105	102	131	136
Varena	0	181	193	225	222	219	219	212	273	283
Carano	453	239	256	297	293	289	289	281	361	372
Castello	<b>776</b>	409	<b>438</b>	<b>508</b>	501	495	495	481	618	638
Valfloriana	0	0	487	565	557	550	550	534	687	709
Stramentizzo	0	0	0	0	0	0	0	0	44	45
Trodona	0	216	232	269	266	262	262	254	328	338
<b>Total</b>	5681	<b>4986</b>	<b>5822</b>	6869	6774	<b>6682</b>	6682	6492	8795	9069
<i>Predazzo, Moena, Daiano</i>		1878	2010	2334	2302	2270	2270	2207	2840	2927
<i>Tesero, Panchia, Ziano</i>		1201	1285	1493	1473	1452	1452	1411	2212	2280
<i>Cavalese, Forno, Varena</i>		1042	1115	1403	1384	1365	1365	1326	1707	1760
<i>Carano, Castello, Valfloriana, Stramentizzo</i>		864	1412	1640	1616	1595	1595	1550	2039	2102
<u>By Village:</u>										
<i>N</i>	5	10	11	12	12	12	12	12	14	14
<i>Pop. largest village</i>	1633	962	1029	1196	1179	1163	1163	1130	1454	1499
<i>% largest village (M)</i>	0.287 365	0.192 905	0.176 81	0.174 027	0.174 035	0.174 069	0.174 069	0.174 007	0.165 319	0.165 29
<i>% largest village (C)</i>		0.826	0.826	0.76	0.76	0.762	0.762	0.762	0.762	0.762
<i>Total pop./N</i>	1136	498	529.	572	564	556	556	541	628	647
<u>By Cluster:</u>										
<i>N</i>		4	4	4	4	4	4	4	4	4
<i>Pop. largest cluster</i>		1878	2010	2334	2302	2270	2270	2207	2840	2927
<i>% largest cluster (M)</i>		0.376	0.345	0.339	0.339	0.339	0.339	0.339	0.322	0.322
<i>Cluster pop./N</i>		1246	1455	1717	1693	1670	1670	1623	2198	2267

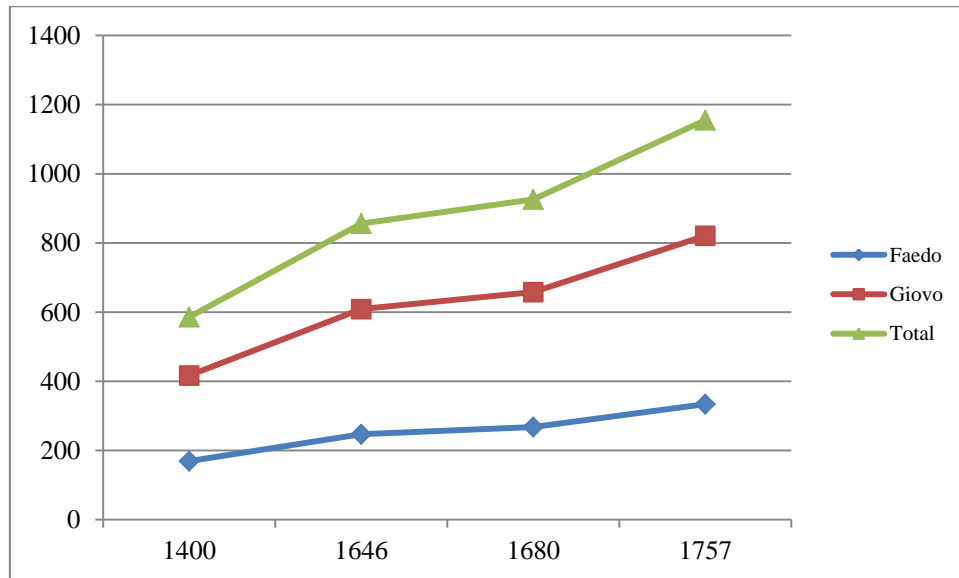
Note 1. Predazzo 1608 is actually a charter of Vardabio, a fraction of Predazzo of which there is no 1810 census data. Predazzo 1615 is the charter of Rucadin, another fraction of Predazzo of which there is no 1810 census data.

Note 2. In the 1533 charter, the organization of collective action of the Valley was structured in three layers. Studies by local historians (Ciresa & Salvotti, 1978) confirm that at the first level there are village meetings where the villagers had to vote (at unanimity or simple majority) the election jurors and regolani (heads of village assembly) for each village, plus a variable number of other village appointments, like officers to monitor private and common forests and arable land to prevent trespassing. At the second level (cluster), the villages ("ville") were organized into four zones (clusters) having separate assemblies of representatives. The third level was the Valley League, having an assembly of a variable number of representatives: the sovereign body of the Valley was the

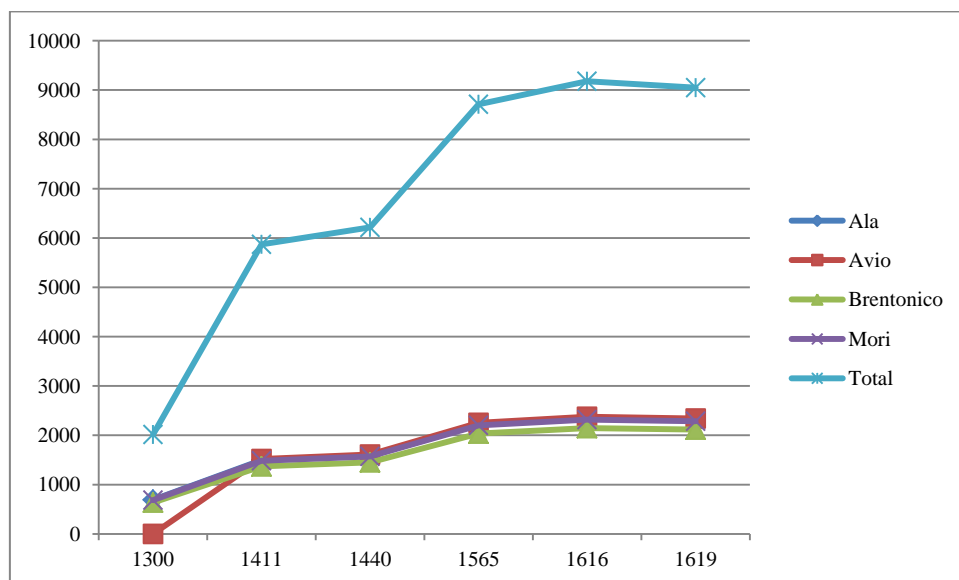
General Assembly (Giunta), which could meet in the *ordinary* form (assembly of 25 village regolani together with all the village members: the 1544 apparently was not an ordinary assembly) or *extraordinary* form (40 participants including the 25 village regolani and the scario). The largest face-to-face interaction unit was the village; therefore, this case is considered as separate village meetings.

### Case Histories: charts.

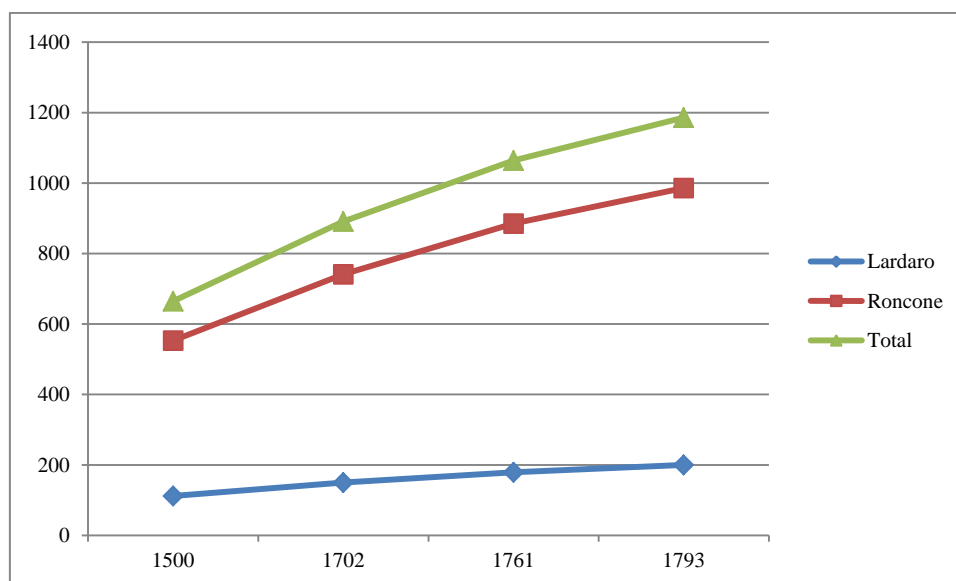
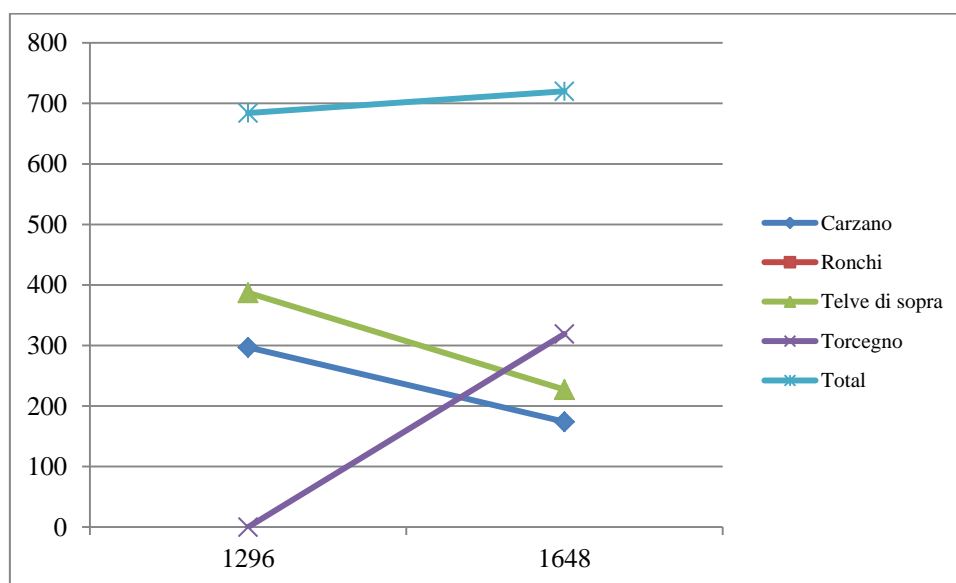
#### *Giovo, Faedo*



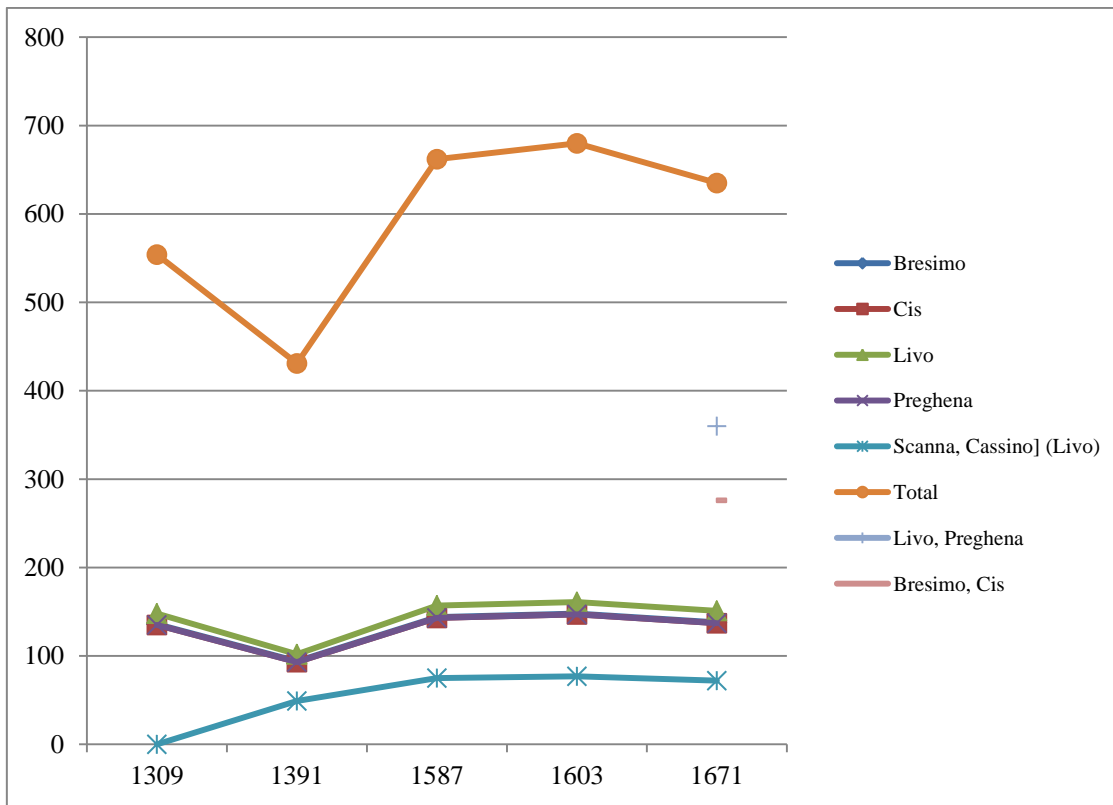
#### *Quattro Vicariati*



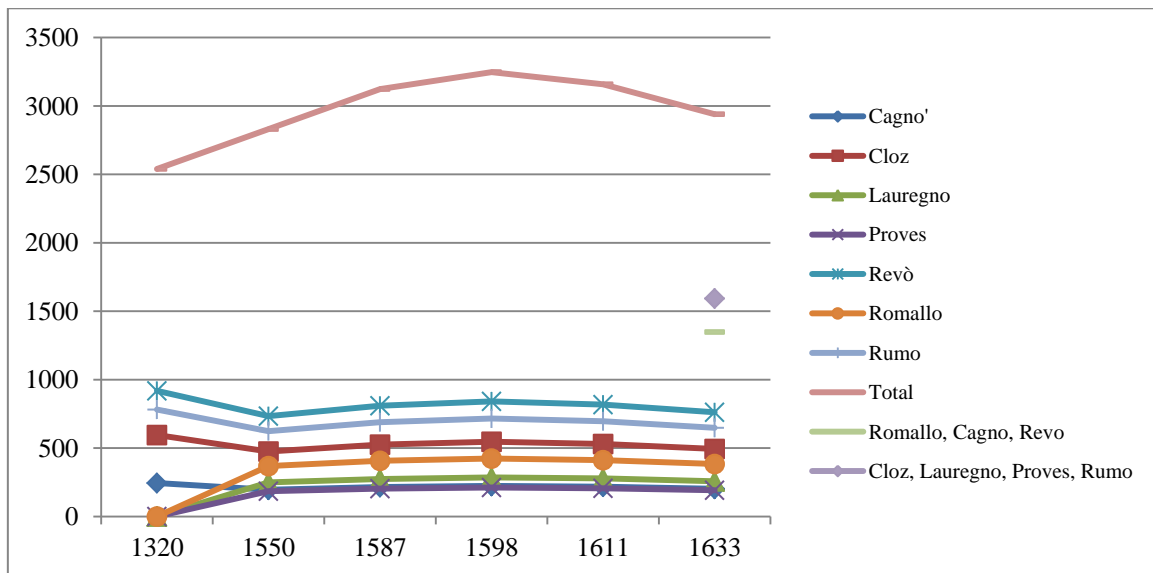


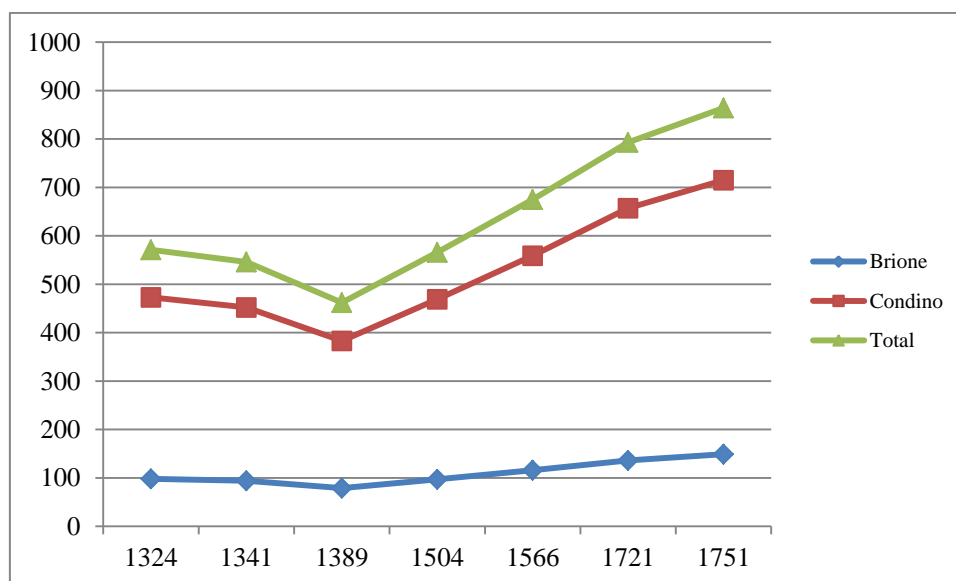
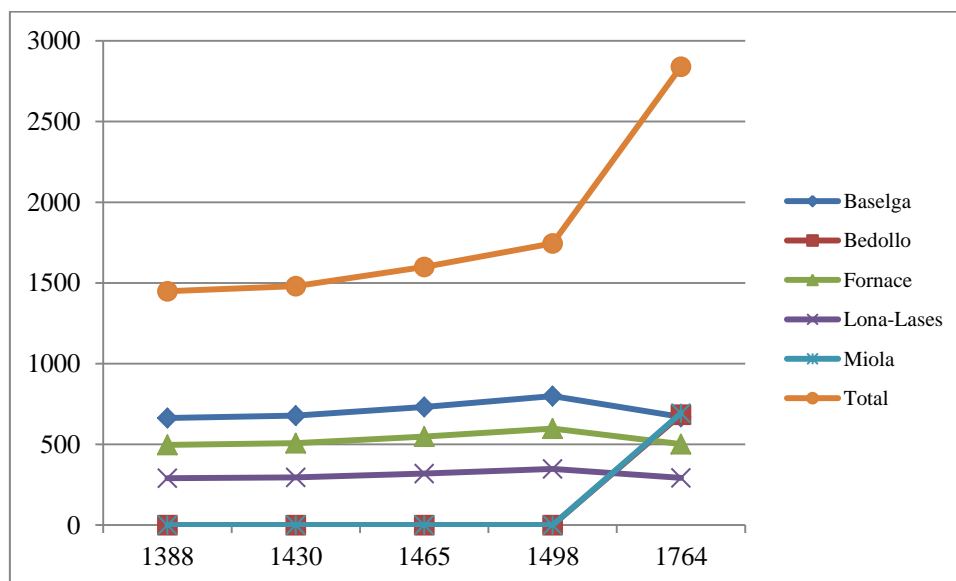
***Roncone, Lardaro******Telve di Sopra***

**Bresimo**

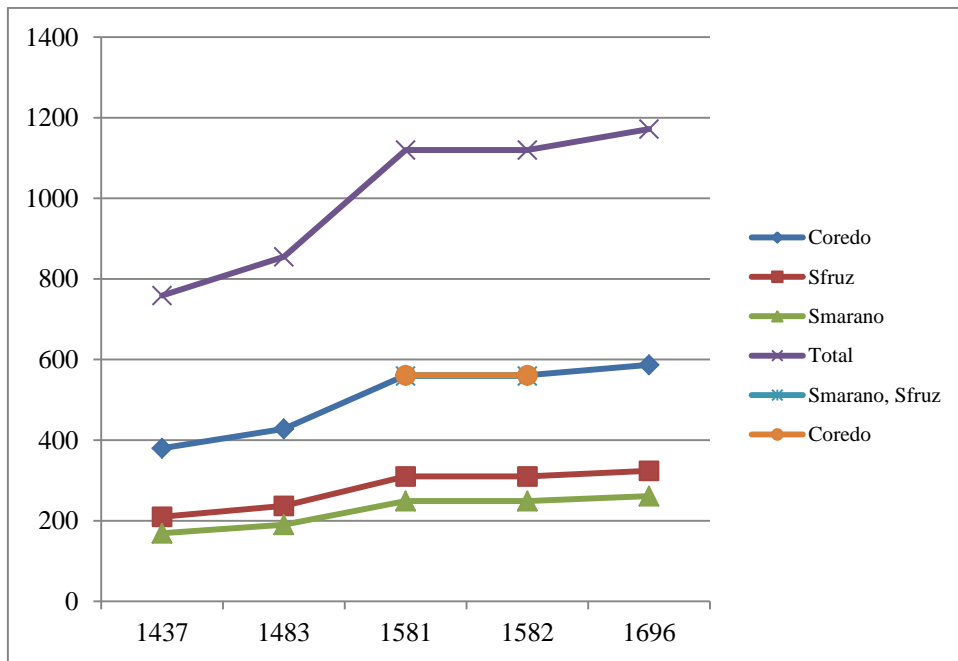


**Revo**

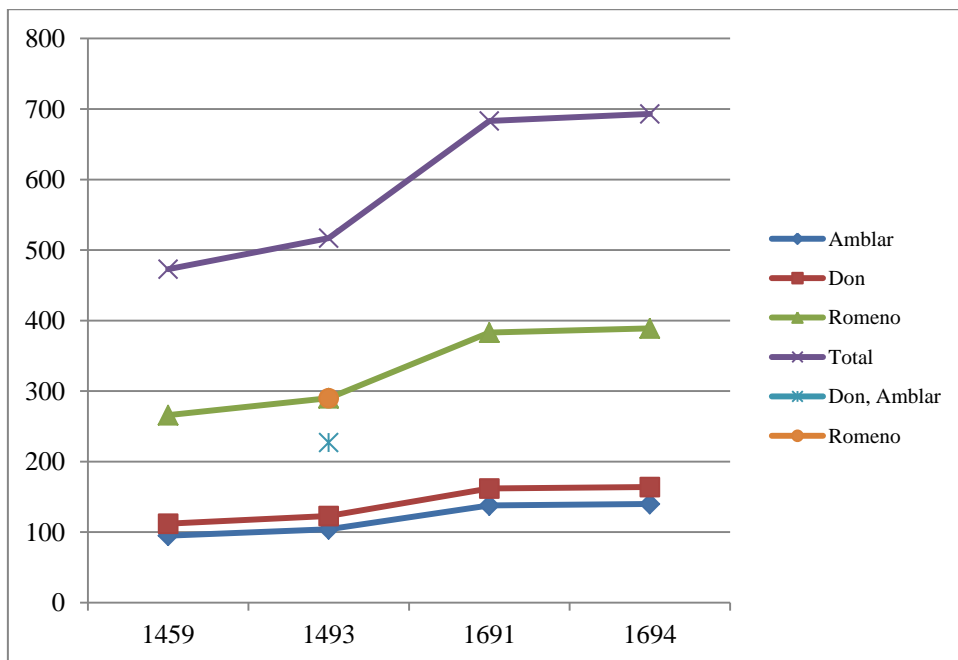


*Condino, Brione**Pine*

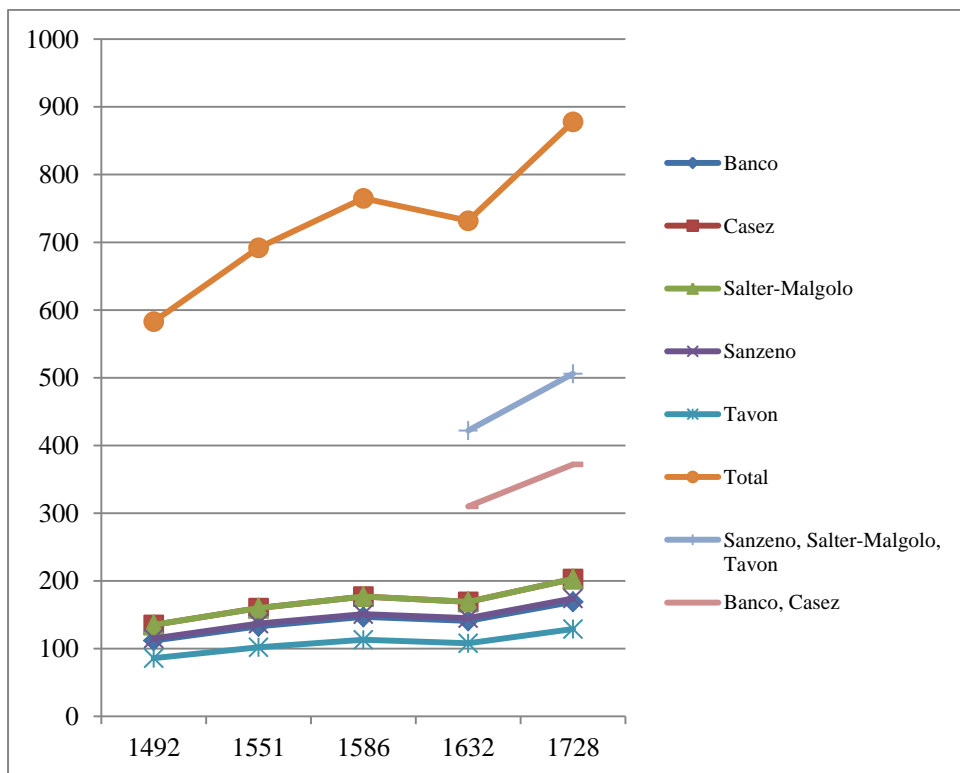
*Coredo, Smarano, Sfruz*



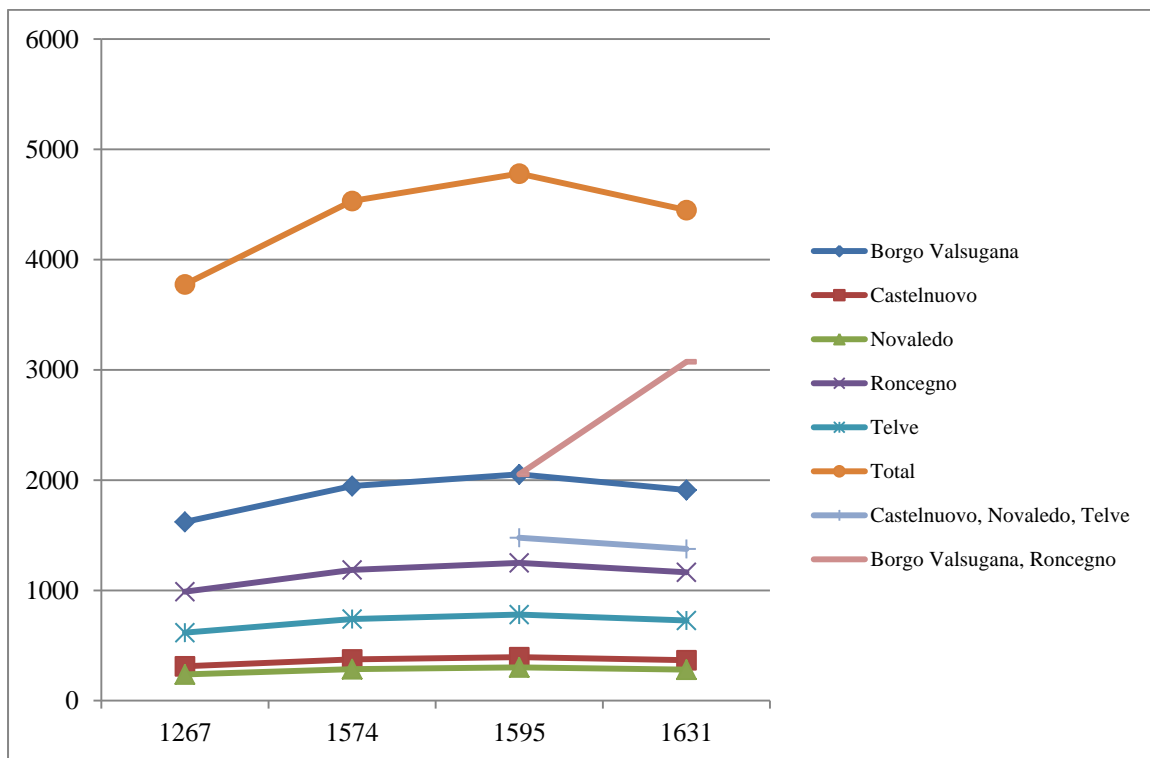
*Romeno, Don, Amblar*



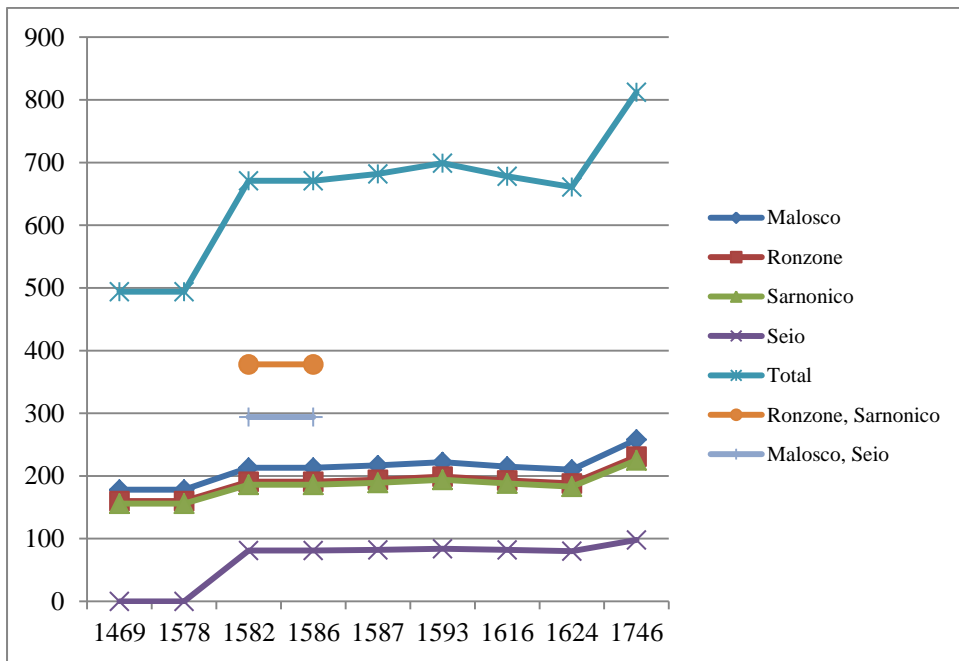
**San Sisinio**



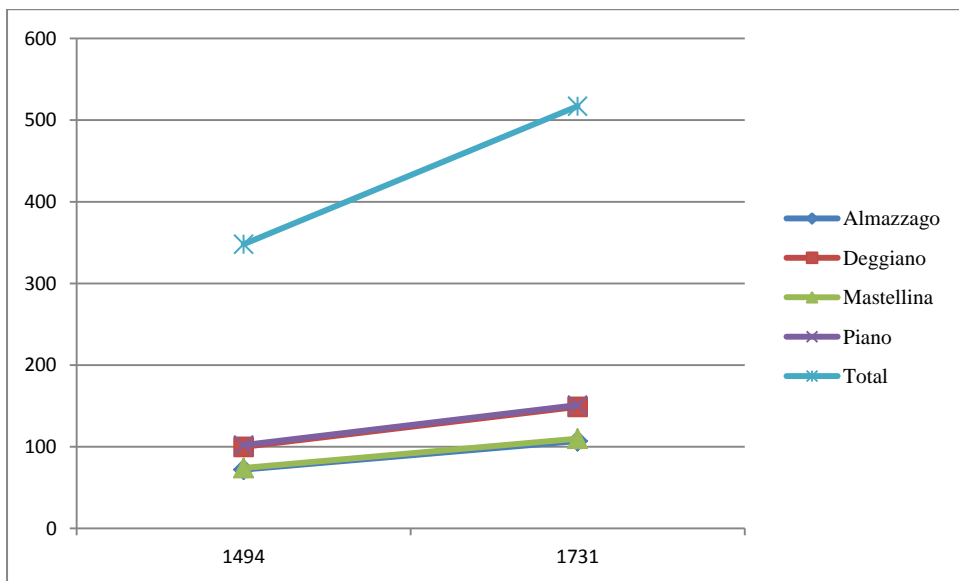
**Telvana**



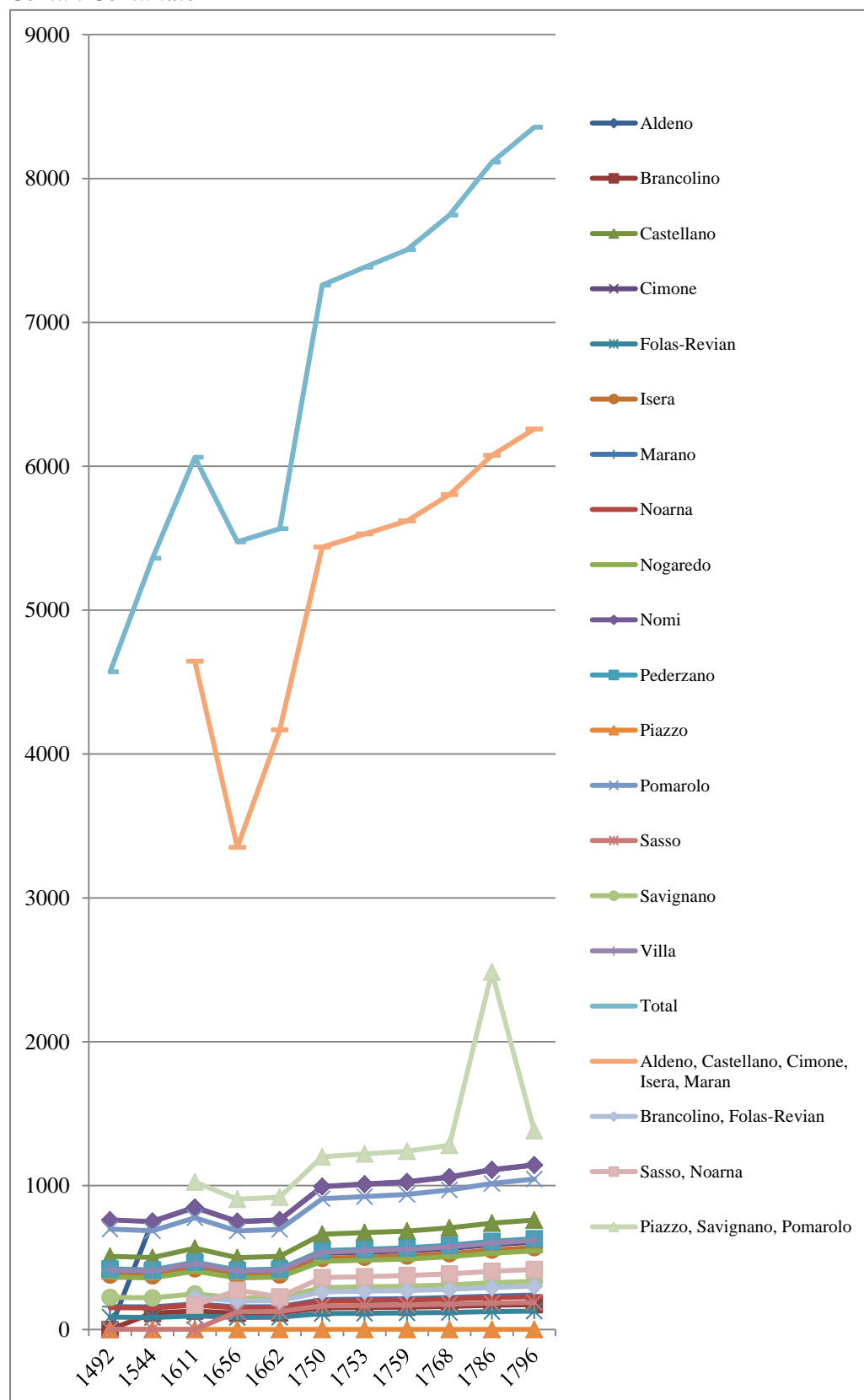
**Malosco**



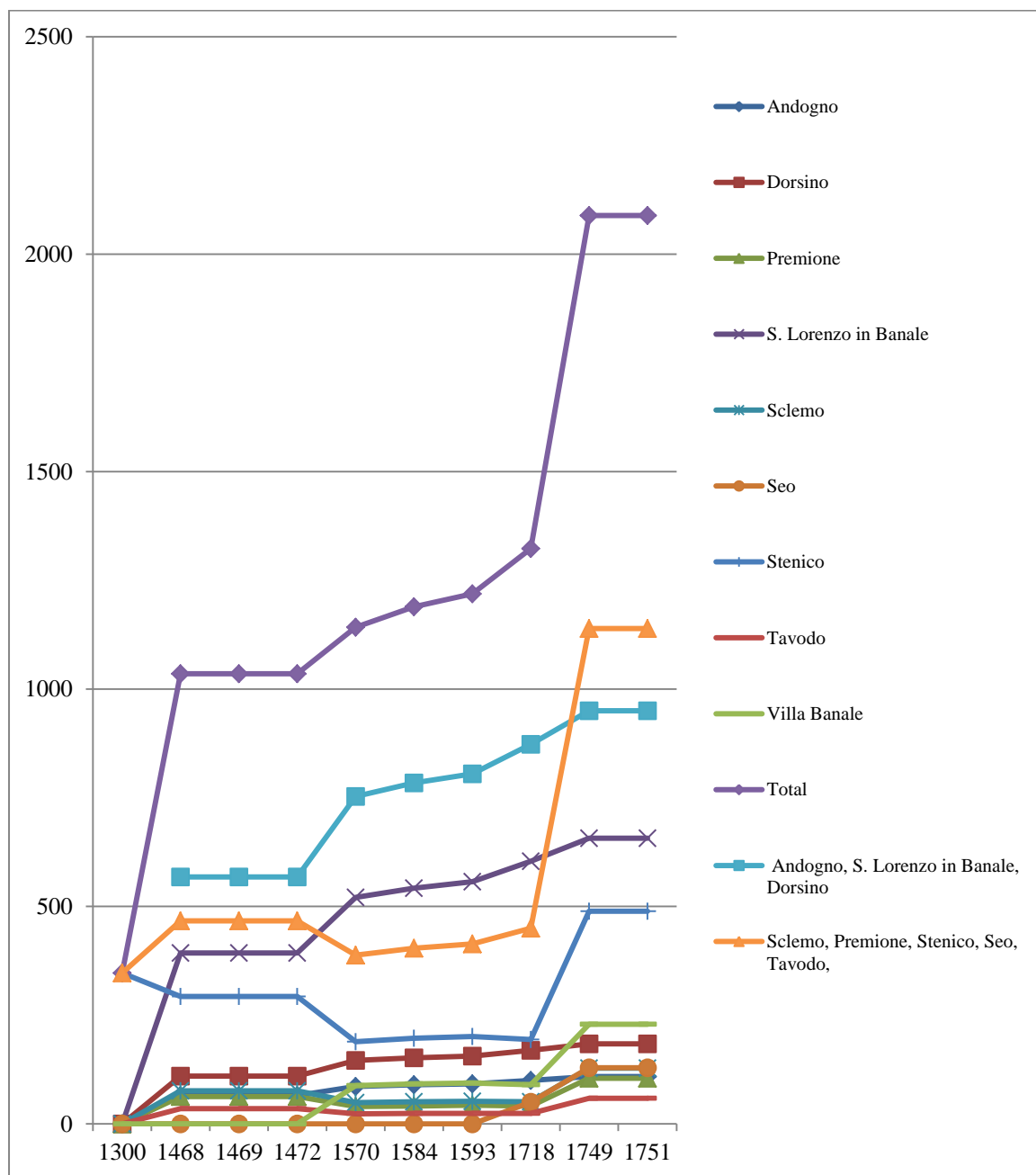
**Commezzadura**



**Comun Comunale**



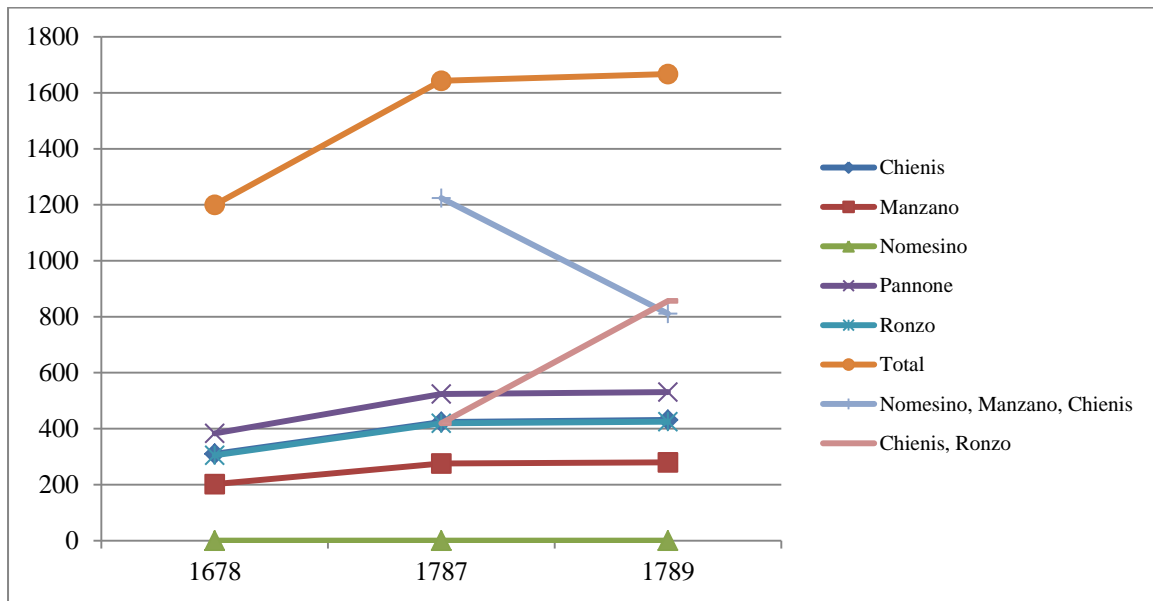
**Pieve del Banale**



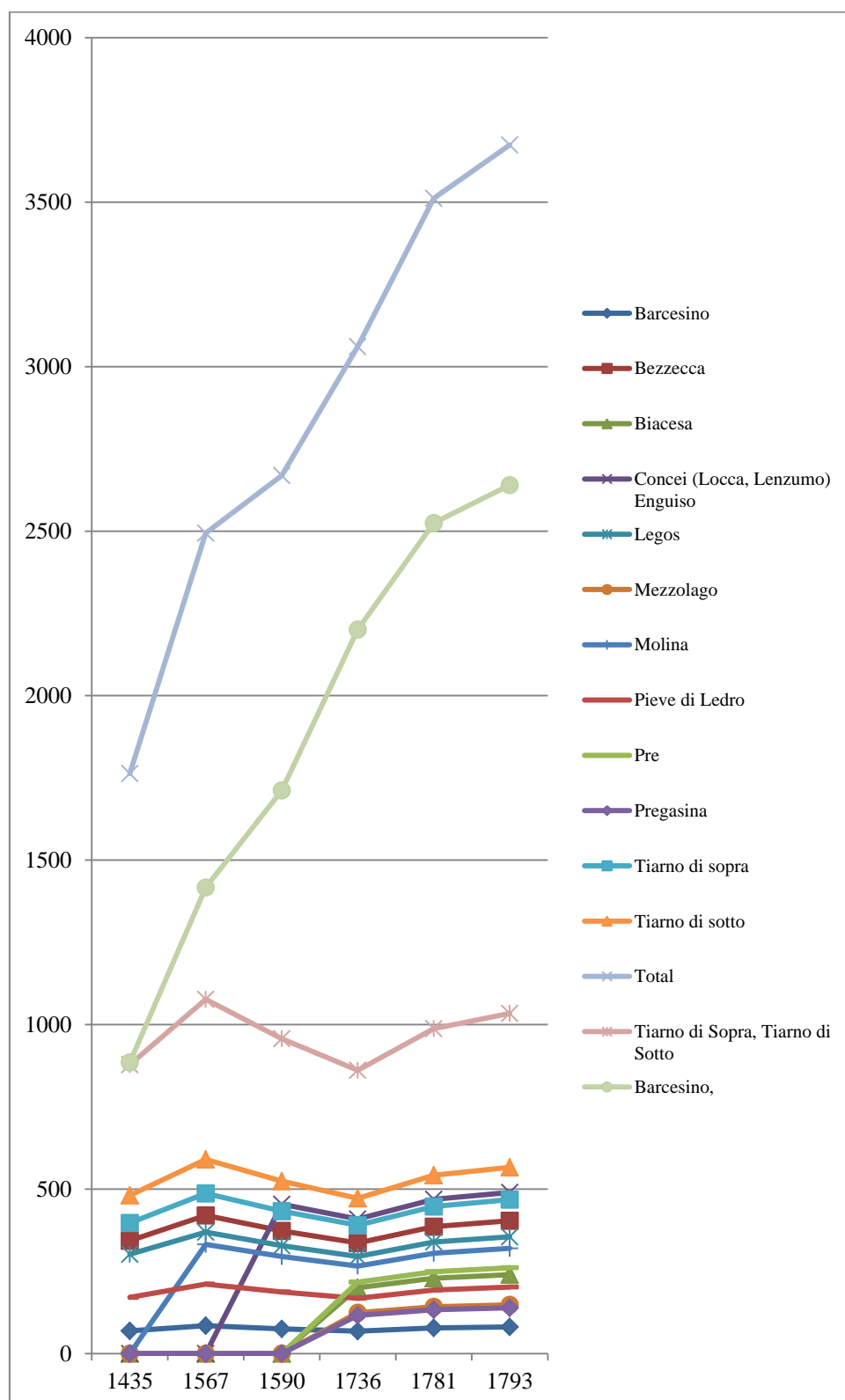




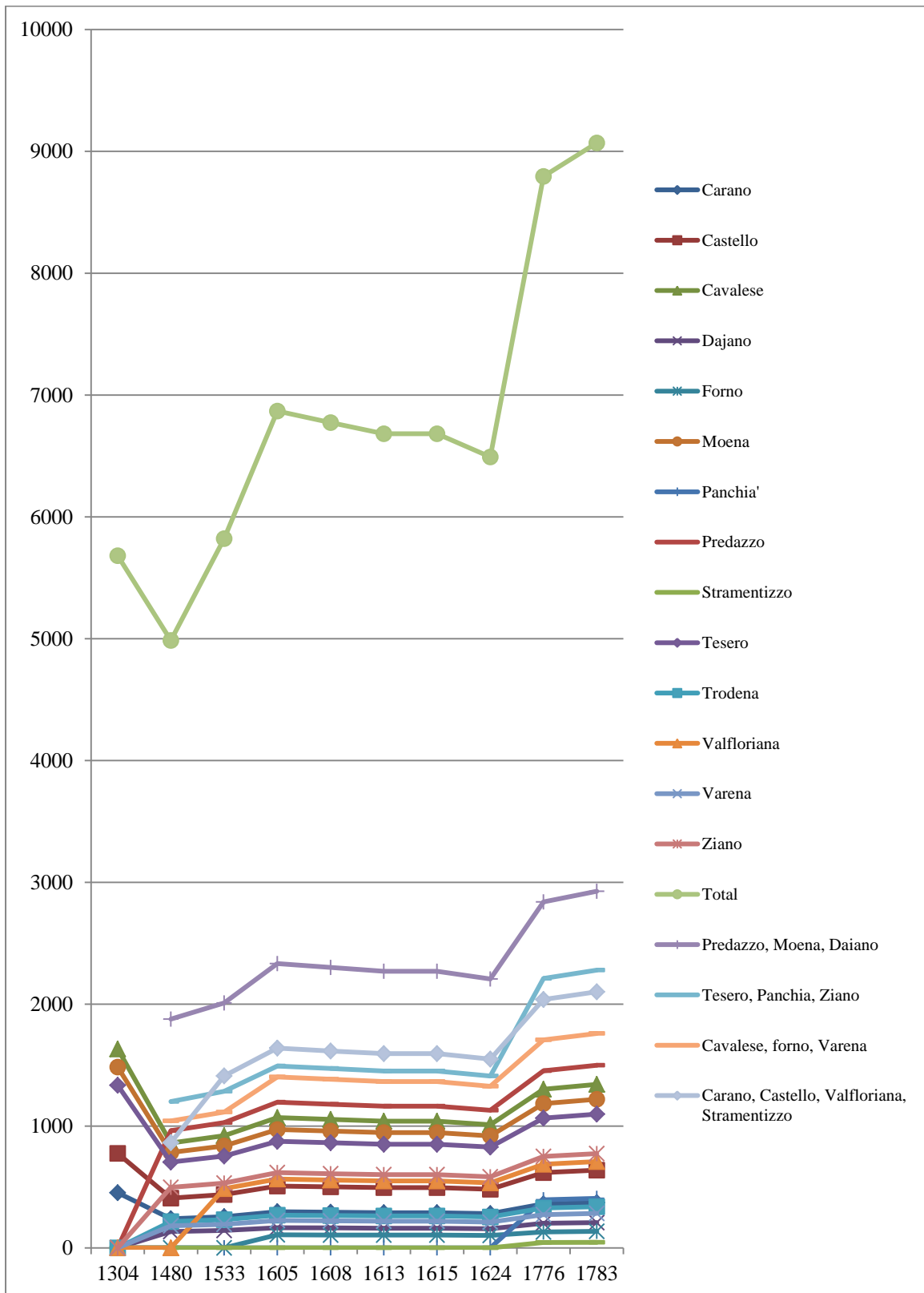
## Val di Gresta



## Val di Ledro



Val di Fiemme



## Appendix F: Codebook of the *Polity* database

### Introduction

The Polity database (version 7, dated **August 14, 2012**) for each of the documents (complete charters and change to charters) reports the following information:<sup>210</sup>

Variable Description	
<i>Variable Description</i>	<i>Type</i>
Assembly ID	Raw, numeric
Year of the assembly.	Raw, numeric
List of government rules (articles).	Coded, string
List of participation rules (articles).	Coded, string
List of constraints on outsiders (articles).	Coded, string
Sum of the articles decided in the observed assembly.	Count, numeric
Cumulative sum of the articles until the closest complete charter.	Count, sum
Number of government rules	Count, numeric
Number of participation rules	Count, numeric
Number of constraints on outsiders rules	Count, numeric
Number of resource management rules.	Count, numeric
Source of the document (complete charter or change to charter).	Raw, string

*Source: Polity v7 (14Aug2012)*

### Inizio e fine del documento

1. Saltare il paragrafo iniziale dove vengono elencati i partecipanti all'assemblea
2. Iniziare la codifica a partire dal primo articolo del documento. Il primo articolo è identificato da diciture come:
  - (a) "Capitolo 1"
  - (b) <1>, [1], etc.
  - (c) "i," "I," etc. seguito da segno di punteggiatura ." "oppure "-"
3. Ogni articolo identifica una "norma." Ciascun articolo è di lunghezza variabile, e può essere approssimato dalla lunghezza del paragrafo che inizia con

<sup>210</sup> This version of the codebook is dated August 14, 2012. The codebook is written in *Italian*: it is assumed that the coder willing to replicate the analyses contained in the paper is able to read the original text of the *Carte di Regola*. The fruitful fruition of the original sources requires a certain degree of familiarity with archives (a comprehensive guide is offered by Casetti (1961)), proficiency in Legal Italian, Medieval Legal Latin (in particular with notarial acts), French (to read the Medieval Latin dictionary by Du Cange (1887)), and knowledge in Medieval and Italian Law.

(a) “Capitolo #”

(b) <#>, [#], etc.

(c) “i...,” “I...,” etc. seguito da segno di punteggiatura .” “oppure “-”

4. Si assume due set di articoli appartenenti a due documenti diversi, ma riferiti alla stessa comunità, siano stati decisi nella stessa assemblea quando hanno congiuntamente

(a) Stessa data:

i. gg-mm-aaaa

ii. mm-aaaa quando gg-mm-aaaa non è disponibile

iii. aaaa quando mm-aaaa

(b) Contiguità/ continuità rispetto allo stesso documento

i. Non vi sono segni o separazioni (come ad esempio una approvazione, o un sigillo notarile) che fanno apparire i due set di documenti come decisi in due assemblee distinte.

5. 5. Interrompere la codifica all’ultimo articolo deciso nella stessa assemblea.

## **Codifica**

1. Gli articoli che compongono il documento così come definiti nella sezione 1 sopra vengono divisi in 4 categorie “normative.”

(a) Government

(b) Participation

(c) Constraints on Outsiders

(d) Resource Management

2. Le sezioni successive contengono una descrizione dettagliata di come ciascuna delle categorie è determinata per consentire la replica della codifica.

3. Ciascun articolo può essere identificato da una e una sola di queste categorie.

4. La somma delle frequenze di tutte le categorie restituisce il totale degli articoli. I totali sono già stati contati dall’Autore.

5. Definizioni delle categorie:

(a) *Government rules*. Norme che definiscono il governo della comunità. Trattano delle modalità attraverso cui gli abitanti del villaggio (gruppo dei “vicini”) sono chiamati a cariche di governo comunitario e i meccanismi di controllo e bilanciamento (checks and balances)

per la gestione efficiente della comunità e la minimizzazione dei costi di agency. Trattano anche del contenuto dei diritti e dei doveri di coloro che sono chiamati a cariche di governo.

(b) *Participation rules*. Norme che stabiliscono le modalità di partecipazione dei “vicini” al governo della comunità nel sistema assembleare. Trattano di modalità di convocazione delle assemblee, condotta da mantenere nelle assemblee, meccanismi di voto per l’assunzione di decisioni, stabiliscono requisiti per la partecipazione a tali riunioni. Stabiliscono quando le assemblee devono tenersi.

(c) *Constraints on Outsiders*. Norme stabilite dal gruppo dei “vicini” a protezione dal rischio di espropriazione da parte dei non residenti nella comunità (siano essi abitanti nella comunità ma privi del diritto di residenza, o anche residenti in comunità limitrofe che hanno interesse nelle risorse della comunità), fattore che a causa dell’incontrollato incentivo al free-riding porterebbe allo sovrasfruttamento delle risorse e al rischio di tragedy of the commons. Sono norme che prevedono un trattamento diverso per i “forestieri” rispetto ai “vicini,” nel senso che prevedono restrizioni (o preclusioni) all’utilizzo di particolari risorse, o prevedono modalità di godimento più onerose o in subordine ai “vicini,” o sanzioni maggiori rispetto a quelle dei “vicini,” o l’esportazione di beni al di fuori della comunità. Sono in genere norme che, ponendo un limite al godimento o dei costi maggiori a carico della frangia dei forestieri, chiudono la comunità (intesa sia come gruppo di persone che come insieme definito di risorse) verso l’esterno mantenendo l’uso delle risorse collettive a solo beneficio della gruppo dei vicini.

(d) *Resource Management Rules*. Tutte le altre norme nel testo.

## Government rules

- Definisco “cariche di governo” gli incarichi determinati validamente dall’assemblea e assunti da individui afferenti alla comunità’ in merito a:
  - cariche di governo (governance)
  - azionamento della carta di regola (enforcement)
  - cariche che impongono un obbligo di fare
  - \* monitoraggio (monitoring)
  - \* riscuotere tasse (enforcement)
  - \* riscuotere di pegni (enforcement)
  - \* sequestri (enforcement)
  - \* comminare sanzioni (enforcement)
  - \* riscuotere sanzioni (enforcement)
- Si considerino nel conteggio solo gli articoli in cui chi ha incarico di governo è soggetto o è destinatario di un obbligo di fare: criteri di selezione, procedure di nomina, deposizione, sostituzione. Sono escluse le facoltà (“liceat,” “ha il potere di,” “può,” etc.)
- Norme che definiscono chi può assumere cariche all’interno della comunità
- Norme che definiscono il numero (preciso, minimo o massimo) di chi può assumere cariche all’interno della comunità
- Norme che definiscono chi può eleggere rappresentanti e giurati del gruppo dei vicini
- Norme che definiscono chi è qualificato a scegliere coloro che assumeranno cariche di governo all’interno della comunità
- Norme che definiscono la periodicità con cui vengono rinnovate le cariche
- Norme che definiscono le assemblee (se ci sono, quando e dove) in cui vengono nominate le persone che assumeranno le cariche
- Norme che determinano le maggioranze richieste per l’approvazione/rinnovo/revoca della nomina
- Norme che definiscono il compenso monetario o altre forme di retribuzione di coloro che assumono cariche di governo
- Norme che definiscono le sanzioni per coloro che si dimostrino negligenti o commettano degli illeciti all’interno della comunità e che detengono un incarico di governo



- Norme che definiscono la periodicità e le modalità del rendimento dei conti (accountability) dell'amministrazione della comunità
- Norme che definiscono e disciplinano modalità e procedure per la risoluzione delle controversie tra abitanti della comunità, tra abitanti della comunità e coloro che hanno incarichi di governo, tra abitanti della comunità e autorità centrale (signori feudali, il Principe Vescovo), tra coloro che hanno incarichi di governo.
- Norme che disciplinano le modalità attraverso le quali chi ha incarico di governo può modificare/introdurre/abrogare nuove Norme.
- Altre Norme che impongono un obbligo di fare/non fare/ astenersi a coloro che hanno incarico di governo.
- Norme che escludono forestieri da cariche di governo e determinano i criteri per elezione dei vicini a cariche di governo.
- Si fornisce, a scopo illustrativo, un elenco di cariche tratto dalla codifica degli elenchi dei partecipanti alle assemblee (in ordine alfabetico):<sup>211</sup>

*Attuario e coauditore massile; Capitano; Capitano militare; Capoconsole; Cavaliere; Comissario; Consigliere; Consigliere e Massaro; Consigliere-giurato; Console; Console-giurato; Console-saltaro; Correggente; Curato; Delegato; Eletto; Gastaldo; Giurato; Giurato e Regolano; Mansionatore; Massaro; Notaio; Notaio pubblico; Notaio rogante; Notaio verbalizzante; Notaio e Giurato; Notaio e accettante; Notaio e cancelliere massarile; Notaio ufficiante; Notaio rogante; Notaio testimone; Notaio-giurato; Notaio-regolano; Procuratore; Rappresentante; Regolano; Regolano maggiore; Regolano minore; Regolano e Giurato; Regolano e Saltaro; Regolano-giurato; Saltaro; Saltaro-giurato; Scrivano; Scrivano e testimone; Scrivante vicinale; Segretario; Segretario verbalizzante; Sindaco; Sindaco speciale; Sindaco e Massaro; Sindaco, Regolano e Massaro; Testimone; Testimone-notaio; Vicario; Vice regolano; Vice regolano maggiore; Vice regolano e giurato; Vice-console; Vicemassaro; Vicereggente.*

---

<sup>211</sup> Si includono anche notai e giurati in quanto a volte sono residenti nella comunità in cui esercitano il loro ufficio e in quanto fisicamente presenti alla gestione faccia a faccia dell'azione collettiva in assemblea.

**Participation rules**

- Norme che disciplinano le modalità e i criteri di partecipazione alle assemblee di comunità
- Norme che disciplinano forme di partecipazione obbligatoria alle assemblee (inclusa anche la convocazione ad assemblee ad hoc).
- Norme che definiscono il quorum costitutivo e deliberativo delle delibere assembleari, o per particolari decisioni.
- Regola che definiscono i poteri di controllo dei vicini sull'operato di coloro che hanno cariche di governo
- Norme che disciplinano la frequenza delle assemblee
- Norme che disciplinano il numero di rappresentanti per ciascuna famiglia e per ciascun villaggio
- Norme che disciplinano la condotta da tenere in assemblea (es: non bestemmie, non portare armi in assemblea, non insultare o far mentire i vicini)
- Norme che disciplinano l'esclusione di particolari categorie di vicini (non forestieri) dalla decisione in merito a particolari materie.
- Norme che demandano all'assemblea il potere di modificare le norme contenute nella carta di regola, determinandone o meno le maggioranze necessarie.

### Constraints on Outsiders

- Norme che contengono la parola “forestieri”/ “advena”/ “forenses”/ “non terrigeno”/ “non residenti”/ “abitante” e simili locuzioni, sia in latino che in italiano o dialetto locale che indicano individui non appartenenti al gruppo dei residenti convocati e abilitati al voto in assemblea, siano essi abitanti nella comunità o anche esterni alla comunità (residenti in una comunità confinante o con rapporti con quella in cui si osserva l’assemblea)
- Norme che determinano una disparità di trattamento tra vicini (gruppo dei residenti) e gruppo dei forestieri in termini:
  - di accesso, estrazione e gestione dei beni comuni (foreste, pascoli, fontane, specchi d’acqua, fonti e pozzi dei villaggi, et similia). Es. Norme di esclusione dal godimento dei beni comuni. Es “Chiunque forestiero non può pascolare sui prati della comunità,” etc.
  - di acquistare la “vicinanza,” il diritto di residenza, di ereditarlo, o di negoziarlo in compravendita o altra figura contrattuale.
  - di acquistare la “vicinanza” tramite matrimonio con residenti nella comunità
  - di essere parte contrattuale nell’affitto o acquisto di terreni (o in altro rapporto contrattuale agrario) nella comunità di cui si osserva l’assemblea
  - di portare i propri animali al pascolo insieme a quelli della comunità di cui si osserva l’assemblea
  - di transitare con i propri animali attraverso i territori della comunità
  - di portare i propri animali al pascolo sui territori della comunità
  - di maggiorazione della pena prevista per illeciti a danno di beni comunitari e beni privati, bestiame, oggetti, etc, solo a danno dei forestieri (per i vicini la pena è prevista in misura minore).
  - di pagamento di somme per poter acquisire il diritto di accesso, uso o usufrutto dei beni collettivi.
- Nel caso in cui in uno stesso articolo vi siano norme che si riferiscono sia ai vicini e ai forestieri (con formule del tipo “sia vicino che forestiero,” ma non “di qualunque condizione”), la norma viene riferita ai forestieri (in quanto comporta comunque una situazione di differenza di comportamento tra le due classi).
- Sono escluse le norme che escludono forestieri da cariche di governo e determinano i criteri per elezione dei vicini a cariche di governo (vanno tra le *Government rules*)
- Sono incluse le norme che, includendo nel novero dei vicini anche abitanti di paesi confinanti, escludono tutti gli altri dalla definizione e pertanto contribuiscono a meglio definire il gruppo dei forestieri e il campo di applicazione delle norme a loro detrimento (es. Vigo Lomaso 1756, n. 77).

**Resource Management rules**

- Categoria residuale che raccoglie tutte le norme che non rientrano nelle precedenti tre categorie, indipendentemente dal loro contenuto.
- Si tratta normalmente di norme riferite alla generalità dei residenti
- Si tratta normalmente di norme riferite alle modalità di gestione delle risorse comunitarie: divieti, permessi, etc. spesso accompagnati da sanzioni (monetarie e non) per la violazione dei precetti contenuti nelle norme.

## Examples

The following are exemplary excerpts from a sample of charter articles extracted from Giacomoni (1991). The selection of the examples from this book was considered an opportunity to allow the reader the easiest access to a large compilation of rural charters.

One example from each century is chosen, but before the French Revolution (1789) and Maria Theresa (1740).

Each example is representative of one of the categories illustrated before, and a translation into English follows each example. The present author's own translations from the sources written in Medieval Latin in the Polity database have been produced using the specialist lexicon (Du Cange, 1887).<sup>212</sup>

The following is an example of governance rule stating the election and replacement of new community officers:

**Example 1.** “<1.>Primo ogni anno sian mudati et cambiati il massaro de' dicti logi et quatro consiglieri, quali cu[m] sagramento] debiano custodir, regere et gubernar bene et dritamente el comune predicto” [Lizzanella, 1494]

*Translation:* “<1.>[it has been decided] that every year the monitoring officer and the four counsels shall be replaced with new ones, who will have to swear the oath and keep, govern, and manage rightfully the aforementioned community.”

The following is an example of participation rule imposing for mandatory attendance to village assemblies for community members, backed by the threat of a monetary fine:

**Example 2.** “<1.>Primo quod quilibet persona comunis dictarum villarum de Dro et de Cenicha qui non venerit ad regullam solvere debeat quinque solidos denariorum parvorum Tridentinorum pro unaquaque vice dicte communitati.” [Dro and Ceniga, 1385]

*Translation:* “<1.>[it has been decided] that whoever from the mentioned villages of Dro and Ceniga do not show up at the community assembly shall pay five small Trentino coins for each of the mentioned villages.”

The following is an example of rule punishing generally non-cooperative behavior in assemblies, backed by a monetary fine:

**Example 3.** “62. Item se alcuno, tanto teriero quanto forestiero, ingiuriasse qualunche persona sopra la regola, che l'ingiuriante sii condannato in lire cinque per cadeuna volta e persona: salva l'accione d'ingiuria all'ingiuriato, sì come anco venisse offeso in factis, al fisco e al medemo ingiuriato.” [Amblar, 1691]

---

<sup>212</sup> The lexicon is available online at <http://ducange.enc.sorbonne.fr/>.

*Translation:* “62. [It has been decided] that if one, both resident and foreigner, were to insult someone during the assembly, he shall be condemned to pay 5 lire per each time and person: [...]”

The following is an example of rule stating the requirement of an assembly quorum for particular decisions:

**Example 4.** “Decimoquarto che non si possa concludere cose di rilievo pubbliche e straordinarie se non con l'intervento di tre delle quattro parti di tutti li vicini di Comezzadura.” [Commezzadura, 1731]

*Translation:* “Fourteen, [it has been decided] that it shall not be possible to decide on issues of public and extraordinary interest without the participation of 3/4 of all the community members of Commezzadura.”

The following is an example of rule placing a constraint on foreigners:

**Example 5.** “<3.>Item si aliquis extraneus fuerit inventus cum bestiis in dictis montibus vel in dicto nemore, si erit claptum admitat pocionem, si non erit claptum amitat .xx. solidos vel unam besstiam meliorem.” [Civezzano, 1202]

*Translation:* “<3.>[it has been decided] that if a foreigner were caught with his cattle on the grazing land of the mentioned mountains or in the mentioned forest, if he was unaware shall he be acquitted, if he did it willfully shall he pay 20 coins or lose one of his better beasts.”

The following is an example of a resource management rule:

**Example 6.** “10. Item che niuno ardisca pascolar cavalli ne' pratti della montagna: in pena de grossi sei per cadaun cavallo, oltre la refacione del danno al danneggiato.” [Cloz, 1550]

*Translation:* “10. [it has been decided] that nobody shall graze horses in the alps: upon a fine of 6 “grossi” for each horse, and in addition to repair the harm to the victim.”