

DOTTORATO DI RICERCA IN
BIOTECNOLOGIE, FARMACOLOGIA E TOSSICOLOGIA
Progetto Formativo 2: “FARMACOLOGIA E TOSSICOLOGIA”

Ciclo XXIII

Settore/i scientifico-disciplinare di afferenza: BIO 14

**INTERACTION BETWEEN APOE4 GENOTYPE AND
ENVIRONMENTAL RISK FACTORS IN ALZHEIMER’S
DISEASE**

Presentata da: Dott.ssa Silvia Maioli

Coordinatore Dottorato

Chiar.mo Prof Giorgio Cantelli-Forti

Relatore

Dott. Roberto Rimondini-Giorgini

Esame finale anno 2011

ABSTRACT

Alzheimer's disease (AD) is probably caused by both genetic and environmental risk factors. The major genetic risk factor is the $\epsilon 4$ variant of apolipoprotein E gene called apoE4. Several risk factors for developing AD have been identified including lifestyle, such as dietary habits. The mechanisms behind the AD pathogenesis and the onset of cognitive decline in the AD brain are presently unknown. In this study we wanted to characterize the effects of the interaction between environmental risk factors and apoE genotype on neurodegeneration processes, with particular focus on behavioural studies and neurodegenerative processes at molecular level.

Towards this aim, we used 6 months-old apoE4 and apoE3 Target Replacement (TR) mice fed on different diets (high intake of cholesterol and high intake of carbohydrates). These mice were evaluated for learning and memory deficits in spatial reference (Morris Water Maze (MWM)) and contextual learning (Passive Avoidance) tasks, which involve the hippocampus and the amygdala, respectively. From these behavioural studies we found that the initial cognitive impairments manifested as a retention deficit in apoE4 mice fed on high carbohydrate diet. In these mice spatial memory retention processes were already compromised at this age. Thus, the genetic risk factor apoE4 genotype associated with a high carbohydrate diet seems to affect cognitive functions in young mice, corroborating the theory that the combination of genetic and environmental risk factors greatly increases the risk of developing AD and leads to an earlier onset of cognitive deficits.

The cellular and molecular bases of the cognitive decline in AD are largely unknown. In order to determine the molecular changes for the onset of the early cognitive impairment observed in the behavioural studies, we performed molecular studies, with particular focus on synaptic integrity and Tau phosphorylation. The most relevant finding of our molecular studies showed a significant decrease of Brain-derived Neurotrophic Factor (BDNF) in apoE4 mice fed on high carbohydrate diet. Our results may suggest that BDNF decrease found in apoE4 HS mice could be involved in the earliest impairment in long-term reference memory observed in behavioural studies.

The second aim of this thesis was to study possible involvement of leptin in AD. There is growing evidence that leptin has neuroprotective properties in the Central Nervous System (CNS). Recent evidence has shown that leptin and its receptors are widespread in the CNS and may provide neuronal survival signals. The signaling cascade that leptin generates are shared by other neuroprotective molecules including insulin and erythropoietin. Chronic administration of leptin resulted in a significant improvement in the cognitive performance of transgenic animal models of AD. However, there are still numerous questions, regarding the molecular mechanism by which leptin acts, that remain unanswered.

Thus, given to the importance of the involvement of leptin in AD, we wanted to clarify the function of leptin in the pathogenesis of AD and to investigate if apoE genotype affect leptin levels through studies in vitro, in mice and in human.

Our findings suggest that apoE4 TR mice showed an increase of leptin in the brain. Leptin levels are also increased in the cerebral spinal fluid of AD patients and apoE4 carriers with AD have higher levels of leptin than apoE3 carriers. Moreover, leptin seems to be expressed by reactive glial cells in AD brains. In vitro, ApoE4 together with $A\beta$ increases leptin production by microglia and astrocytes. Taken together, all these findings suggest that leptin replacement might not be a good strategy for AD therapy. Our results show that high leptin levels were found in AD brains. These findings suggest that, as high leptin levels do not promote satiety in obese individuals, it might be possible that they do not promote neuroprotection in AD patients. Therefore, we hypothesized that AD brain could suffer from leptin resistance. Further studies will be critical to determine whether or not the central leptin resistance in SNC could affect its potential neuroprotective effects.

Contents

1.1 ALZHEIMER'S DISEASE.....	6
1.1.1 Neuropathology	7
1.1.1.1 Amyloid plaques	7
1.1.1.2 Neurofibrillary tangles.....	10
1.1.1.3 Synaptic and neuronal loss	11
1.1.2. Brain-derived neurotrophic factor	14
1.1.3 Activity-regulated cytoskeletal-associated protein.....	15
1.2.1 Familial Alzheimer's disease (FAD).....	18
1.2.2. Sporadic Alzheimer's disease (SAD).....	18
1.2.3 Apolipoprotein E4	19
1.2.3.1 Role of apoE in CNS	20
1.2.3.2 ApoE and A β	20
1.2.3.3 ApoE and neurofibrillary tangles.....	21
1.2.3.4 ApoE, cholesterol and synaptic integrity.....	22
1.2.3.5 ApoE and cholinergic dysfunction.....	23
1.2.3.6 ApoE and signalling.....	23
1.2.3.7 ApoE and neurotoxicity.....	24
1.2.4 Other risk and protective factors in AD	25
1.2.4.1 Cerebrovascular disease	25
1.2.4.2 Blood pressure.....	26
1.2.4.3 Type 2 diabetes	26
1.2.4.4 Plasma lipid levels	26
1.2.4.5 Smoking.....	27
1.2.4.6 Depressive symptoms	27
1.2.4.7 Psychological stress	27
1.2.4.8 Physical and intellectual activity.....	27
1.2.4.9 Diet.....	28
1.3.1 High saturated fat diet and AD	30
1.3.2 Cholesterol and AD	31

1.3.3 High carbohydrate diet and AD.....	32
1.3.4 Insulin-signaling pathway	33
1.3.6 Leptin.....	35
1.4 THERAPY FOR AD	40
3. MATERIALS AND METHODS.....	43
3.1. ANIMALS	43
3.2 BEHAVIOURAL TESTING.....	44
3.2.1. Morris Water Maze.....	44
3.2.2 Passive Avoidance.....	45
3.3 TISSUE PREPARATION.....	46
3.3.1. Immunoblotting	46
3.4 CELL CULTURES AND TREATMENTS.....	47
3.4.1 Microglial human cells CHME3.....	47
3.4.2 Primary cultures of astrocytes.....	47
3.4.3 Neuroblastoma SH-SY5Y.....	48
3.4.4 Cell treatments	48
3.5 HUMAN SAMPLES.....	49
3.5.1 CSF samples.....	49
3.5.2. Postmortem samples and Brain tissue preparation.....	49
3.5.2.1 Samples for immunoistochemistry	49
3.5.2.2 Samples for RT PCR.....	50
3.5.3 Immunostochemistry and Immunofluorescence.....	50
3.5.4 mRNA levels.....	51
3.6. STATISTICAL ANALYSIS	51
4. RESULTS.....	53
7. FIGURES	67
7. REFERENCES.....	89

1. INTRODUCTION

1.1 ALZHEIMER'S DISEASE

In 1907 Alois Alzheimer described the case of a 51-years old woman who presented a relatively rapid deteriorating memory along with psychiatric disturbances. She died 4 years later.¹ While a variety of progressive and fatal neurologic conditions were known at that time, including dementia. The early age of the onset and the new pathological finding, the neurofibrillary tangle (NFT), made this condition unique. Alzheimer's disease is the most common cause of dementia, accounting for an estimated 60-80 percent of all dementia cases. It is one of the most important public health problem of the 21st century and the seventh cause of death. Last year's World Alzheimer Report, estimated that there are 35.6 million people worldwide living with AD (5.5 million in the United States) and the estimated cost were \$ 422 billion US dollars for 2009.² The main risk factor for developing AD is age and the risk is doubled every 5 years after 65 years of age. The diagnosis is of 1275 new cases per year per 100.000 persons older than 65 years of age.³ As the aging population increases, the prevalence will approach 13.2 to 16.0 million cases in the US by mid-century.⁴

The symptoms of this irreversible neurodegenerative disorder occur gradually and result in memory loss, progressive impairment of activities of daily living, unusual behaviour, personality changes and a decline in thinking abilities. Episodic memory, which is defined as the ability to recall past experiences, is disrupted in AD and typically appears to be the first cognitive domain that is affected in AD patients:^{5,6} Impaired ability to learn new information or to recall previously learned information, such as difficulty remembering names and recent events is often an early clinical symptom. The disease onset is insidious and manifestations evolve over a period of years from mildly impaired memory to severe cognitive loss. A transitional state, referred to as mild cognitive impairment (MCI), often precedes the earliest manifestations of AD.⁷ As the disease progresses, other cognitive deficits manifest, particularly in attention, executive functions, semantic memory, language and spatial orientation.⁸ The course of Alzheimer's disease is inevitably progressive and terminates in mental and functional incapacity and death.

In AD, the progressive nature of neurodegeneration suggests an age-dependent process that ultimately leads to degeneration of synaptic afferent systems, dendritic/neuronal damage and the formation of abnormal protein aggregates throughout the brain.

1.1.1 Neuropathology

As clinical AD symptoms overlap substantially with other disorders of the central nervous system, a definite diagnosis of AD can only be obtained after post-mortem brain examination. The key pathological changes that are observed in AD brain tissue are increased levels of amyloid- β ($A\beta$) peptide and hyperphosphorylated tau protein (p-tau). $A\beta$ is deposited extracellularly in diffuse and neuritic plaques and p-tau is a microtubule assembly protein that accumulates intracellularly as neurofibrillary tangles (NFTs). In addition to these pathological hallmarks of AD, widespread loss of neurons and synapses is observed.⁹ The temporal and regional distribution differs between NFTs and plaques. NFT pathology starts in the medial temporal lobe (entorhinal cortex and hippocampus), spreads to the limbic areas and finally to neocortical association areas.¹⁰ The plaques are first visible in orbitofrontal and temporal cortices. The spread continues further to parietal cortex and throughout the neocortex. The clinical symptoms reflect the NFTs neuropathology: the first signs are short-term memory problems, which reflect the early pathology in the hippocampus. The memory problems will later develop into difficulties with executive functions, including planning and initiation of actions, as well as emotional disturbances and apathy. Executive functions are mainly controlled by the prefrontal cortex, interconnected cortical and subcortical brain structures.

1.1.1.1 Amyloid plaques

An important pathological feature of AD is the presence of extracellular amyloid plaques in the brain. Amyloid plaques are composed of aggregations of small peptides called β -amyloid ($A\beta$). $A\beta$ is a peptide of 39-43 amino acids (aa) that is able to form β -sheets structures and fibrillar aggregates.^{9,11} There are two forms of amyloid plaques in the AD brain: neuritic plaques (also called senile plaques) and diffuse plaques. The neuritic plaques are extracellular deposits of fibrillar $A\beta$ in dystrophic neurites that show NFT pathology, containing activated microglia within the central amyloid core. Reactive astrocytes surround the neuritic plaques. The plaques can also be diffuse without a compacted core and neuritic dystrophy. It is believed that diffuse plaques are immature precursors of neuritic plaques. It has been shown that the activation of microglia by fibrillar $A\beta$ is a very early phenomenon in the AD pathogenesis. The localization of astrocytes at the neuritic plaques occurs much later when dementia is already developing. One explanation for this could be that microglia has been found to be involved in the clearance of $A\beta$ by phagocytosis. The activated microglia can also

produce toxic products, like reactive oxygen species and pro-inflammatory cytokines that could contribute to neurodegeneration.¹²

The amyloid cascade hypothesis is the most dominant theory that has been proposed over the years to explain the pathogenesis of AD.¹³ Multiple lines of evidence demonstrate that overproduction/aggregation of A β in the brain is a primary cause of AD so that inhibition of A β generation has become a hot topic in AD research. According to the amyloid cascade hypothesis a chronic imbalance between the production and clearance of A β leads to synaptic dysfunction, formation of intraneuronal fibrillary tangles, glial activation and eventually neuron loss in affected areas of the brain.^{14,15} There are two main toxic species, A β 40 and A β 42, with A β 42 more hydrophobic and more prone to fibril formation.¹⁶ Studies done on familial AD mutations consistently show increases in the ratio of A β 42/40,¹⁷ suggesting that elevated levels of A β 42 relative to A β 40 is critical for AD pathogenesis, probably by providing the core for A β assembly into oligomers, fibrils and amyloidogenic plaques.¹⁸ Extracellular neuritic plaques are deposits of small peptides with different length called β -amyloid. These peptides are derived via sequential proteolytic cleavages of the β -amyloid precursor protein (APP), a transmembrane protein with a large extracellular domain and one transmembrane region. The *APP* gene is located on chromosome 21 in humans with three major isoforms arising from alternative splicing (APP695, APP751 and APP770).¹⁹ APP751 and APP770 are expressed in most tissues and contain a 56 amino acid Kunitz Protease Inhibitor (KPI) domain within their extracellular regions. APP695 is predominantly expressed in neurons and lacks the KPI domain.²⁰ There are reports showing that the protein and mRNA levels of KPI-containing APP isoforms are elevated in AD brains and associated with increased A β deposition.²¹ Prolonged activation of extra synaptic NMDA receptor in neurons can shift APP expression from APP695 to KPI containing APP isoforms, accompanied with increased production of A β .²² These findings may suggest that a dysregulated splicing of *APP* RNA contributes to disease pathogenesis. APP belongs to a protein family that includes APP-like protein 1 (APLP1) and 2 (APLP2) in mammals.²³ All these proteins are type-I transmembrane proteins and are processed in a similar fashion. The A β domain is unique to the APP protein. Although APP has been the subject of much study since its identification, its physiological function remains largely undetermined. Different roles of the APP protein have been suggested, such as in neurite outgrowth and synaptogenesis, neuronal protein trafficking along the axon, transmembrane signal transduction, cell adhesion, calcium metabolism. All of these different functions requires additional *in vivo* evidence.²⁴ APP is proteolyzed into

various fragments during its intracellular trafficking and these APP metabolites mediate various and sometimes adverse functions. Therefore, the net effect of full-length APP on cellular activity may be a combination of its metabolites' functions, temporospatially depending on the proportion of levels of each APP metabolite. APP can be cleaved by different secretases in an intricate cascade manner, giving rise to an amyloidogenic and to a non-amyloidogenic pathway. APP and the secretases are transmembrane proteins and the APP processing occurs in the membrane environment. Firstly β -secretase (β -site amyloid precursor protein-cleaving enzyme, BACE) cleaves APP extracellularly, and produces soluble APP (sAPP β) and a membrane bound C-terminal fragment (CTF, C99). C99 is further cleaved in the transmembrane region by γ -secretase resulting in the release of APP intracellular domain (AICD) and A β .²⁵ This is called amyloidogenic pathway. Two forms of the amyloidogenic peptide are produced, A β 40 and A β 42. A β 42 is more prone to aggregate and more toxic than the more abundant A β 40.²⁶ In the non amyloidogenic pathway, APP is cleaved by α -secretase within the A β domain, resulting in the release of sAPP α into the extracellular space. Membrane bound C83 is further processed by γ -secretase, and the presumably non toxic P3 and AICD are produced. P3 is a short hydrophobic protein with the size of 3 kDa and includes A β 17-40 and A β 17-42.²⁷

There are several observations that suggest that the amyloid cascade hypothesis is lacking in detail. The biggest concern is that it does not explain the reason for the increased A β production in sporadic cases, where no mutation in the genes encoding amyloid precursor protein (*APP*) or presenilin1/2 (*PSEN 1/2*) is present. Another concern is that similar plaques were found in non-demented subject without affecting the cognitive performance.²⁸ Moreover, the number of plaques is not well correlated with the severity of the disease and there is evidence for A β not being an initial trigger of the AD. In frontotemporal dementia with Parkinsonism mutations in the tau gene only and tangle formation but not deposition of A β were observed. The final test for the amyloid cascade hypothesis in humans is to study if cognitive performance is affected by a reduction in A β levels in the brain. Results from a small phase I immunization study, using active A β (1-42) were recently published. In this study immunisation resulted in clearance of plaques, but this did not prevent further progressive neurodegenerative changes in AD patients.²⁹ Larger studies with passive immunisation are ongoing. Despite many efforts to elucidate the deficiencies of the A β

hypothesis, an alternative hypothesis explaining the cause and early pathogenesis of AD has not yet emerged.

1.1.1.2 Neurofibrillary tangles

Studies on the clinical-to-pathological correlation have consistently demonstrated that the number of neurofibrillary tangles, and not the plaques, correlates best with the presence and/or the degree of dementia in AD.^{30,31} Neurofibrillary degeneration appears to be required for the clinical expression of the disease, while amyloid plaques in the absence of neurofibrillary degeneration does cause clinical symptoms. Not only in AD but also in every known human tauopathy, the tau pathology symptoms were associated with the abnormally hyperphosphorylated protein.^{32,33}

NFTs are intra neuronal inclusions of abnormally hyperphosphorylated tau, a microtubuli-associated protein, which self-assembles into paired helical filaments (PHF) building the tangles.³⁴ Two major normal functions of tau are its ability to promote the assembly of tubulin into microtubules and to stabilize the microtubule structure. In the central nervous system, Tau is a family of six proteins derived from a single gene by alternative splicing of its pre-mRNA.³⁵ The human brain Tau isoforms range from 352 to 441 amino acids. All six isoforms have been reported to be present in an abnormally hyperphosphorylated state in neurofibrillary tangles of paired helical filaments. The functions of tau are regulated by its degree of phosphorylation.³⁶ AD brains contain 4-8 fold of abnormally hyperphosphorylated tau.³⁷ The hyperphosphorylated form of tau will no longer bind tubulin, or promote the assembly into microtubules. The disruption of the main structure for axonal transport will compromise the transport within cell, preventing vesicles to reach the synapse, and slowly the synapses will degenerate associated with retrograde degeneration.

The state of phosphorylation of a phosphoprotein is a function of the balance between the activities of the protein kinases and the phosphatases that regulate its phosphorylation. Tau, which is phosphorylated at over 38 serine/threonine residues in AD is a substrate for several kinases.³⁸ Among these kinases, glycogen synthase kinase-3 (GSK-3), cyclin dependent protein kinase-5 (cdk5), protein kinase A (PKA), calcium and calmodulin-dependent protein kinase II (CaMKII), casein kinase-1 (CK-1), MAP kinase ERK1/2 and stress activated protein kinases have been most implicated in the abnormal phosphorylation of tau.³⁹ GSK-3 β and cdk5 phosphorylate tau at a large number of sites, most of which are common to the two enzymes. The expressions of GSK-3 β and cdk5 have been associated with all stages of

neurofibrillary pathology in AD.^{40,41} Overexpression of GSK-3 β in cultured cells and in transgenic mice results in hyperphosphorylation of tau at several of the same sites seen in AD.^{42,43} Cdk5 requires for its activity interaction with p39 or p35, or their proteolytic products p29 or p25,^{44,45} which are generated in post mitotic neurons by digestion with calpains. Overexpression of p25 in transgenic mice also produces hyperphosphorylation of tau.⁴⁶ The MAP kinase family, which includes ERK1, ERK2 and the stress activated kinase JNK and p38 kinase, have been shown to phosphorylate tau at several sites. Some of these sites are the same as for the abnormally hyperphosphorylated tau, suggesting the association of these enzymes with the progression of the neurofibrillary degeneration in AD. The sequential phosphorylation of tau by priming kinases (PKA, CaMKII), that will markedly increase tau phosphorylation of the other kinases, is believed to be important for hyperphosphorylation to occur.⁴⁷ It has been shown that certain sites such as Thr²¹², Ser²¹⁴, Thr²³¹, Ser²³⁵ and Ser²⁶² are the major sites in the inhibition of the binding of tau to microtubule.⁴⁸ The protein phosphatase (PP) 2A is believed to be the major phosphatase for tau, but PP-1 is also involved in the dephosphorylation. The activities of both enzymes have been reported to be decreased by 20% in AD brain.⁴⁷

1.1.1.3 Synaptic and neuronal loss

The dementia in AD is associated with neurodegeneration, that is characterized initially by synaptic injury followed by neuronal loss.⁴⁹ The cognitive alterations in AD are closely associated with synaptic loss and neurofibrillary tangles. Brain regions involved in AD typically exhibit reduced numbers of synapses and neurons. Neurons using glutamate or acetylcholine as neurotransmitters appear to be particularly affected. Loss of neurons in the entorhinal cortex, hippocampus, frontal, parietal and temporal cortices of AD patients has been reported.^{50,51} Neurons in layer II of the entorhinal cortex and hippocampal CA1 neurons are particularly vulnerable. Alzheimer's disease may primarily be a disorder of synaptic failure. Hippocampal synapses begin to decline in patients with mild cognitive impairment (a limited cognitive deficit often preceding dementia) in whom remaining synaptic profiles show compensatory increases in size. In mild Alzheimer's disease, there is a reduction of about 25% in the presynaptic vesicle protein synaptophysin. With advancing disease, synaptic loss correlates well with decline in cognitive functions.⁴⁹ Aging itself causes synaptic loss, which particularly affects the dentate region of hippocampus. Basal transmission of single impulses and long-term potentiation, an experimental indicator of memory formation at synapses, are

impaired in plaque-bearing mice after the A β peptide has been applied to brain slices.^{52,53} Subsequent to this impairment, signaling molecules are inhibited. Disruption of the release of presynaptic neurotransmitters and postsynaptic glutamate receptor ion current occur partially as a result of endocytosis of N-methyl-D-aspartate (NMDA) surface receptors and endocytosis of α -amino-3-hydroxy-5-methyl-4-isoxazole propionic acid (AMPA) surface receptors.⁵⁴⁻⁵⁶ A similar shift in the balance between potentiation and depression in synapses occurs with normal aging. Intraneuronal A β can trigger these synaptic deficits even earlier.⁵⁷

It is presently unknown how the hallmark features of AD neuropathology, plaques and tangles, relate to emergence of cognitive impairment. It is well established that the number of plaques does not correlate with cognitive performance in AD patients,³¹ although, the number of tangles is a better predictive measure of overall cognitive function in humans with a clinical AD diagnosis. Still, tangles cannot be used as a reliable biomarker for the onset of early cognitive changes. Synaptic loss appears the marker that best correlates with cognitive dysfunction in AD patients⁵⁸. This is an early pathological hallmark of Alzheimer's disease, although the trigger underlying the synaptic dysfunction is not yet resolved. The human studies are corroborated by data from various transgenic mouse models of AD. These models show that cognitive impairment emerge prior to any overt neuropathology and correlate poorly with plaque number, supporting the notion that synaptic damage occurs early in disease progression. The pattern of neuronal loss in AD overlaps with, but is not identical to, that of normal ageing, suggesting that AD pathogenesis is not simply acceleration of normal brain ageing.

The underlying molecular mechanisms of AD pathogenesis have not yet been identified; therefore, three major hypotheses have been advanced regarding the primary cause. The earliest hypothesis suggests that deficiency in cholinergic signalling initiates the progression of the disease. Loss of cholinergic neurons seems to be specifically associated with typical clinical symptoms, like memory deficits, impaired attention, cognitive decline, and reduced learning abilities. The first-generation therapeutics against AD was based on this hypothesis and work to preserve acetylcholine by inhibiting its degrading enzyme acetylcholine esterase (AChE). These medications have not led to a cure. In all cases, they have served to only treat symptoms of the disease and can delay the progression of AD by 1-2 years but failed to reverse it. Therefore, it was concluded that ACh deficiencies may not be the direct cause of the disease.

The hypothesis that Tau is the primary factor causing the disease has been grounded on the fact that AD neuropathology starts in most individuals with hyperphosphorylated Tau and neurofibrillary tangles long before the first signs of A β occur.^{10,59} One mechanism for neurotoxicity could be that hyperphosphorylated and aggregated Tau impairs axonal transport in murine Tau transgenic models and cellular models. Problems with axonal transport are believed to be a major cause leading to the pathological observed in AD and other neurodegenerative diseases. Advances in the understanding of AD pathogenesis provide strong support for a modified version of the amyloid hypothesis. The basic tenant of this modified hypothesis is that an intermediate misfolded form of A β , neither a soluble monomer nor a mature aggregated polymer but an oligomeric species, triggers a complex pathological cascade leading to neurodegeneration.⁶⁰ The relationship between APP, axonal transport and aberrant A β processing is not as easy as for Tau. Axonopathy and transport deficit can be detected long before extracellular A β deposition in AD patients. Impairment of axonal transport might be a cause or an effect of aberrant A β production or a result from APP overexpression. Axonal transport is of great importance for proper neuronal function. Finally, ApoE4, the major risk factor for sporadic AD, may directly disrupt the cytoskeleton and hence impair axonal transport.

Neurotrophins may be the actors allowing to link between cholinergic degeneration, amyloid and tau pathologies and axonal transport. Neurotrophic factors (NTF) are small, versatile proteins that maintain neuronal survival, axonal guidance, cell morphology and play key roles in cognition and memory formation. Axonal transport processes are essential for proper neurotrophin factor signaling. Most neurodegenerative diseases are linked to failure in axonal transport, and not surprisingly, the majority of them are associated with impaired regulation and imbalance of neurotrophins. Neurotrophic factors are key regulators not only for development, maintenance and survival but also for cognition, formation and storage of memory. The normally high levels of neurotrophin receptors in cholinergic neurons in the basal forebrain are severely reduced in late-stage AD. Injection of nerve growth factor (NGF) can rescue basal neurons in animal models⁶¹ and a phase 1 trial of treatment with NGF gene in AD shows improvement in cognition and brain metabolism.⁶² Moreover, in AD and mild cognitive impairment, levels of brain-derived neurotrophic factor (BDNF), another member of the neurotrophin family, are depressed.⁶³ BDNF treatment in rodents and non-human primates support neuronal survival, synaptic function, and memory, suggesting that BDNF replacement could be another option for the treatment of AD.⁶⁴

1.1.2. Brain-derived neurotrophic factor

BDNF is an activity-dependent secreted protein, which along with its receptors, is widely expressed in the central nervous system. It is critical to organization of neuronal networks and synaptic plasticity, especially in the hippocampus, in a variety of animal models and in humans. BDNF is critical for memory formation and long term potentiation (LTP). Further, BDNF is thought to regulate neurogenesis. The induction of LTP increases BDNF mRNA⁶⁵ as well as TrkB mRNA⁶⁶ in the dentate gyrus. In addition, it has been shown that hippocampal LTP and spatial learning are impaired in mice lacking BDNF⁶⁷ as well as in mice lacking *trkB*.⁶⁸ BDNF has been directly related to learning rates in spatial memory paradigms.^{69,70} By blocking either the release of BDNF or the binding of BDNF to its receptor (TrkB), long term potentiation is effectively eliminated in the hippocampus.⁷¹ Furthermore, inducing BDNF production and secretion in the hippocampus can rescue long term potentiation and relieve spatial memory deficits in aged mice.⁷² In a rodent of successful aging with a longer life span and preserved memory capacities, BDNF levels were higher than in animals that experience normal age-related patterns of decline. Based on the age-related decline in the expression of BDNF and TrkB in the hippocampus, one would expect that BDNF-induced LTP may be weaker in older animals. Concerning this, it has been shown that in aged rats, BDNF-LTP is significantly impaired within the hippocampus and that the activation of TrkB is reduced in hippocampal tissue derived from aged rats.⁷³ Thus, BDNF seems to play a key role in synaptic plasticity, memory formation and storage, probably through induction of morphological changes. Therefore, the involvement of BDNF in neurodegenerative diseases has been discussed extensively. BDNF has been convincingly demonstrated to relate Alzheimer's disease pathology. In this light, it is not surprising that mRNA expression as well as BDNF protein are decreased in hippocampus and neocortex of AD brains.^{63,74,75} Three of six transcripts, which code for BDNF, are down regulated⁷⁶ and two of these are controlled by a cyclic adenosine 5-phosphate response element-binding protein (CREB) responsive promoter. CREB deregulation appears to be involved in the pathogenesis of AD.⁷⁷ BDNF also moderates tau formation⁷⁸, β -amyloid neurotoxicity⁷⁹ and hippocampal-dependent memory performance in animal models of Alzheimer's disease.^{80,81} BDNF and its precursor PRO-BDNF deficiencies were found to be present not only in cases of severe AD, but even in earlier mild stages of the disease such as mild cognitive impairment.⁸² Therefore, BDNF deficiency may be an early hallmark of AD and a factor in the progression of the disease. Moreover, a recent study showed that increased serum BDNF levels were associated with

poorer memory performance in Alzheimer's disease cases.⁸³ However, the degree to which serum BDNF reflects BDNF levels in brain remains a matter of speculation.⁸⁴ A link combining BDNF and AD pathogenesis is BDNF as regulator of GSK-3 β . BDNF increases the phosphorylation of S9-GSK-3 β , which turn the kinase activity off.⁸⁵ BDNF regulation is maintained through cholinergic innervations and through NMDA receptors.

Concerning a possible role of BDNF in Alzheimer's disease, it has been shown that BDNF post-mortem brains from Alzheimer's disease patients display an absence of BDNF. This has been shown in both reactive glial cells of microglia cells and in neurons containing neurofibrillary tangles. Most neurons, which are intensely immunoreactive for BDNF, did not exhibit massive neurofibrillary degeneration.^{86,87} The age-related decline in BDNF could contribute to changes seen in conditions of normal aging. Further disturbances in the BDNF-system may be related to pathological changes in the brain. Along this line, there is not only evidence to suggest that disturbances in the hippocampal BDNF-system contribute to neurodegenerative diseases such as Alzheimer's disease, but also to psychopathological conditions such as depression.

1.1.3 Activity-regulated cytoskeletal-associated protein

The Activity-regulated cytoskeletal-associated protein (Arc) is a single copy gene that is highly conserved in vertebrates. Since the 1960s it has been known that long term storage of information in the brain is dependent on rapid, de novo RNA and protein synthesis.⁸⁸ Similar macromolecular synthesis is essential for long-term forms of synaptic plasticity such as long-term potentiation (LTP) and long-term depression (LTD). These activity-dependent changes in synaptic efficacy are suggested to underlie learning and memory. Among all the genes that mediate protein synthesis-dependent plasticity, the immediate early gene Arc has proven to be the most tightly couples to behavioural encoding of information in neuronal circuits in vivo.⁸⁹ Arc mRNA and protein induction during behavioural learning is so robust and reproducible that cellular imaging of Arc induction is a powerful methodology for detecting neural networks that underlie information processing and memory.⁸⁹ In vivo, Arc is coordinately induced in populations of neurons that mediate learning such as place cells of the hippocampus⁹⁰ and behaviour-specific neural networks in the cortex.⁹¹ For example, 5 min of spatial exploration elicits transcriptional induction of Arc in ~40% of CA1 neurons.⁸⁹

Unlike most other immediate early gene products, the Arc protein is not a transcription factor. It is instead a cytosolic protein that acts as an effector protein downstream of multiple neuronal signaling pathways.

Arc expression is confined to the brain and testis and seems to almost exclusively be expressed in CaMKII-positive glutamatergic neurons in hippocampus and neocortex, with little or no expression in glial cells.⁹² Arc protein is found in the postsynaptic density (PSD) and copurifies with the NMDA receptor complex⁹³, but it is not found in presynaptic terminals or axons. The tight transcriptional regulation of Arc seems to be determined by multiple transcriptional enhancer sites that contain binding domains for a set of transcription factors, including SRF, MEF2 and CREB. The precise signaling cascades involved in Arc transcription are not well defined. One study showed that PKA and MAPK cascades are involved in Arc induction.⁹⁴ Arc transcription is also regulated by neuronal spiking and calcium influx through voltage-sensitive calcium channels (VSCCs)⁹⁵ and by group 1 metabotropic glutamate receptors (mGluRs).⁹⁶ The precise kinetics of transcription and translation of Arc appear to differ according to which receptors and signaling pathways are used and this has important implications for Arc's role in neuronal plasticity.

Arc mRNA is transported to dendrites and becomes enriched at the site of local synaptic activity, suggesting that Arc protein is locally synthesized. In addition to regulated transport of Arc mRNA in dendrites, Arc mRNA undergoes a form of nonsense-mediated decay in dendrites that results in limited translation of protein from a single mRNA. This exquisite regulation of mRNA and protein localization and expression suggests that Arc is important for synaptic function and that dysregulation of Arc expression may have dire consequences for brain function.⁹⁷

The properties of activity-dependent Arc protein and mRNA induction immediately suggested a role in memory consolidation, so it is not surprising that the first studies on Arc was concentrated on its regulation and function in the hippocampus. Arc knockout (Arc^{-/-}) mice exhibit impaired consolidation of long-term memory, without alteration of short-term memory.⁹⁸ Infusion of Arc antisense oligodeoxynucleotides (ODNs) in the rat hippocampus blocked consolidation in a spatial memory task.⁹⁹ Similarly, Arc antisense ODN infusion in the lateral amygdala blocked the consolidation of Pavlovian fear conditioning.¹⁰⁰ These findings suggest that Arc has a conserved role in information storage in limbic forebrain memory systems.

Dysregulation of Arc expression has been implicated in Alzheimer's disease. Amyloid β peptide is the major component of neuronal plaques in AD and as already described, contributes to the pathogenesis of the disease. Even at low levels A β may interfere with signaling cascades critical for the synaptic plasticity that underlies learning and memory. Moreover, it is becoming clear that oligomeric species of A β may even have a normal role in homeostatic regulation of glutamate transmission.¹⁰¹ A number of findings suggest that Arc may contribute to the cognitive and A β -dependent synaptic dysfunction observed in Alzheimer's disease. A β depresses AMPA receptor currents in slices and induces AMPAR endocytosis via a process similar to mGluR LTD.⁵⁶ Oligomeric forms of A β have been shown to induce Arc expression.¹⁰² Arc expression is severely disrupted in Alzheimer's disease mouse models. In some cases extremely high levels of Arc have been observed and in others there is a lack of normal Arc induction after experience. BDNF is well known to be capable of inducing the synthesis of Arc. Recent studies suggest that A β blocks BDNF-induced Arc expression, perhaps by inhibiting the PI3-Akt-mTOR pathway.¹⁰³ However, the role of the mTOR pathway in Arc expression is controversial, as another study found no role for mTOR in Arc induction or Arc-dependent plasticity in vivo.¹⁰⁴ These studies highlight the need to understand precisely how Arc expression is affected in Alzheimer's disease.

Taken together, these findings suggest that overexpression or dysregulation of Arc protein levels is potentially a causative factor in a number of neurological disorders, since Arc is a critical effector molecule downstream of many signaling pathways, dysfunction of Arc could be a nexus point for synaptic dysfunction in neurodegenerative diseases. As dysregulation of Arc expression is found in many cognitive disorders, it will be critical to assess the role of Arc in these disorders. Although Arc dysregulation may be a manifestation of the disease pathogenesis and not a causative agent, correcting Arc expression may still be a very relevant target for alleviating disease symptoms. However, it will be important to know precisely why and how Arc expression is disrupted in these disorders.

1.2 GENETICS AND RISK FACTORS OF AD

In general, two subgroups of AD are recognized upon the age at which the first clinical symptoms become apparent; early-onset AD (onset age <65years), termed familial Alzheimer's disease (FAD), and late-onset AD (onset age >65years), termed sporadic Alzheimer's disease (SAD).

1.2.1 Familial Alzheimer's disease (FAD)

FAD is genetically inherited in an autosomal dominant fashion and has an early onset of the disease.¹⁰⁵ Although most patients develop AD at later age, it is mainly the research performed on the rare autosomal dominant early-onset form of AD that provided valuable insights into disease pathogenesis. There are mutation in three known genes causing FAD: the amyloid precursor gene (APP, on chromosome 21), the presenilin 1 gene (PSEN1 on chromosome 14), and the presenilin 2 gene (PSEN2 on chromosome 1). Currently, 23 missense mutations have been reported in APP, 178 mutations in PSEN1, and 14 mutation in PSEN2 (AD mutation database, [http://www.molgen.ua.ac.be/AD mutation](http://www.molgen.ua.ac.be/AD%20mutation)). An increase dosage of APP also enhances the severity of AD. Duplicate APP is linked to early onset AD with several cerebral amyloid angiopathy.¹⁰⁵ Down syndrome patients with trisomy 21 (three copy of APP) show features of AD over the age of 35¹⁰⁶ and A β was found in the plaque core of aged Down syndrome patients.¹⁰⁷ In most of the cases APP mutations increase the ratio of A β 42/A β 40 or total A β production. The mutations in PSEN are missense mutations, insertions or deletions and they are located in the transmembrane regions or in the hydrophilic loops in the cytosol. PSEN mutations result in increased ratio of A β 42/A β 40.¹⁰⁵

1.2.2. Sporadic Alzheimer's disease (SAD)

SAD has a late onset (>65 years of age) and is responsible for over 95% of all AD cases. SAD is probably caused by several both genetic and environmental risk factors.¹⁰⁵ The major genetic risk factor is the ϵ 4 variant of apolipoprotein E gene (*ApoE*, on chromosome 19) called *apoE4*.¹⁰⁸ The apolipoproteins are cholesterol transporters of high importance for repairing neurons and for maintaining lipid and cholesterol homeostasis. In addition to AD, *apoE4* is also associated with several other neurodegenerative disorders. Recently, high-throughput genomic association studies on extensive populations have opened up new avenues in detecting susceptibility factors for late-onset AD. Three novel risk genes have been identified: the clusterin gene (CLU, also known as apolipoprotein J gene, APOJ) CR1

(the receptor gene for the complement C3b protein), PICALM1 (encoding for the phosphatidylinositol-binding clathrin assembly protein)¹⁰⁹.

Risk factors for developing AD have been identified including health conditions, genetic and heredity, gender, education, age, and lifestyle. Taken together these evidences show that AD is a multifactorial disease. However, the mechanisms behind the AD pathogenesis are still unknown.

1.2.3 Apolipoprotein E4

The strongest known risk factor influencing the incidence of sporadic AD is the genotype for apolipoprotein E (apoE). ApoE is a polymorphic 299-aa protein and is the major carrier of cholesterol in the central nervous system. The gene, located on chromosome 19, encodes three alleles: apoE2 (frequency in population 7-8%), apoE3 (60-70%) and apoE4 (15-20%). In 1991, familial studies demonstrated linkage of AD with markers on chromosome 19.¹¹⁰ Two years later apoE was implicated in late onset familial and sporadic AD.¹¹¹ Individual with one or two copies of apoE4 have a higher risk of developing AD and also an earlier onset of the disease (from 84 in non carriers to 68 in E4 homozygotes)^{112,113} compared with carriers of other isoform.¹¹⁴ On the other hand, the presence of apoE2 had a protective effect by delaying the onset and decreasing the risk for AD. This discovery has been confirmed by epidemiological and genetic studies with a large number of study subjects. It is estimated that 65% of late onset and 80% of early onset AD can be accounted by the presence of apoE4.¹¹⁵ The apoE polymorphism seen in humans is unique and it has been proposed to appear as a result of evolutionary adaptative changes. The three isoforms differ only at residues 112 and 158. ApoE3 has Cys-112 and Arg-158, whereas apoE4 has arginine at both sites, and apoE2 has cysteine. This substitution affects the three-dimensional structure and the lipid-binding properties between isoforms. In apoE4 the amino acid substitution results in a changed structure with the formation of a salt-bridge between an arginine in position 61 and a glutamic acid in 255 that causes this isoform to bind preferentially to VLDL. ApoE3 and apoE2 bind preferentially high-density lipoprotein (HDL).¹¹⁶

ApoE is a major determinant of the recognition and uptake of lipoproteins through the low density lipoprotein (LDL) receptor, the LDL receptor related protein (LRP), the apoE receptor 2, the very low density lipoprotein (VLDL) receptor and megalin. ApoE plays an important role in the distribution and metabolism of cholesterol and triglycerides within many organs and cell types in the human body.¹¹⁷

1.2.3.1 Role of apoE in CNS

The largest production of apoE is found in the liver, followed by the brain. In the CNS, astrocytes are the major cell type that produces apoE, although neurons express apoE under physiological and pathological condition.¹¹⁸⁻¹²⁰ ApoE has critical functions in redistributing lipids among CNS cells, through the LDL receptor-related family for normal lipid homeostasis, repairing injured neurons, maintaining synaptodendritic connections and scavenging toxins. ApoE3 seems more effective in the normal maintenance and repair of cells than ApoE4, which may be detrimental in these processes.

1.2.3.2 ApoE and A β

Decreased A β clearance or increased A β deposition has been suggested to play an important role in AD pathogenesis.²⁵ The discovery of autosomal dominant mutations in the APP and presenilin genes (PS) genes, which result in an overall increase in production of A β (1-42) emphasized the idea that overproduction of A β is a causative agent of AD. Several lines of evidence suggest that at least some of the pathological effects of apoE4 may be mediated by interactions with the A β cascade. Both in vitro and in vivo studies demonstrate that apoE4 inhibits A β clearance and/or stimulates A β deposition, leading to plaque formation.¹²¹

ApoE is present in neuritic plaques and A β levels are elevated in brains of AD patients carrying apoE4.¹²² Similar findings have been observed with transgenic mice expressing human apoE isoforms.^{123,124} Moreover, several studies showed differences in the binding of apoE3 and apoE4 to A β . However, it remains to be elucidated if apoE4 has an active role in facilitating A β aggregation and/or deposition. In contrast, apoE3 and E2 may have a protective role by inhibiting A β aggregation or favouring A β clearance. ApoE4, in a lipid-free form has a greater avidity for A β than apoE3, but it has also been shown that apoE3 and E2 bind more rapidly to A β when associated with lipoproteins.¹²⁵ The dosage of apoE was found to be determinant for plaque deposition in a mice overexpressing the mutant human APPV717F.¹²⁶ In APPV717F mice bred onto a mice expressing human apoE in astrocytes, it was found that apoE3 favours A β clearance, as apoE3-APPV717F mice showed reduced A β deposition compared with apoE4-APPV717F mice. Interestingly, in another mice model overexpressing a mutant variant of human APP, it has been shown that levels of A β and apoE in brain increased in parallel with age, at the expense of a decrease of A β in plasma. This would suggest that elevations of brain apoE levels during aging would deregulate A β

clearance and increase A β sequestration. Post-mortem studies have shown that A β deposition is increased in ApoE4 carriers in both sporadic and genetic AD cases. Recently, it has been shown that the cognitive impairment seen in APP transgenic mice depends both on apoE and on amyloid formation.¹²⁷

Neuronal ApoE receptors may also have several roles in APP trafficking and processing as well as in A β clearance and apoE4 has been found to enhance the synthesis of A β by promoting endocytic recycling of APP.¹²⁸ Finally, in vitro data demonstrate that apoE increases the neurotoxicity of A β in an isoform-specific manner (E4 > E3). In addition, a study has shown that the impairments in neuroplasticity induced by apoE4 following environmental stimulation in a transgenic mice model are associated with the accumulation of intraneuronal A β .¹²⁹ These findings suggest the existence of synergistic pathological effects between A β and apoE4.

1.2.3.3 ApoE and neurofibrillary tangles

Abnormal phosphorylation of the tau protein leading to the formation of NFTs is a common feature of AD and several other neurodegenerative disorders. Tau hyperphosphorylation compromises the normal functioning of the neuron leading to its death. The hypothesis that apoE isoforms may differently influence tau pathology derives from in vitro studies, where apoE3 and not apoE4 forms a (SDS)-stable complex with tau. Phosphorylation of tau inhibits its interaction with apoE3 suggesting that apoE3 only binds to non-phosphorylated tau. This further suggests that apoE3 might be able to prevent abnormal tau hyperphosphorylation and destabilization of the neuronal cytoskeleton.¹³⁰ Transgenic mice studies have shown increased phosphorylation of tau in mice expressing human apoE4 in neurons, but not in mice expressing apoE4 in astrocytes¹³¹. This indicates a neuron-specific effect of apoE4 on tau phosphorylation. In addition, intraneuronal accumulation of hyperphosphorylated tau has been found in apoE KO mice fed with a high cholesterol diet, suggesting a synergic interaction of dietary cholesterol and lack of apoE function.¹³²

It has been proposed that the amino terminal domain of apoE3 is responsible for binding to tau. Additionally, studies in transgenic mice have shown that carboxyl-terminal-truncated apoE stimulates tau phosphorylation and intracellular NFT-like inclusion formation. A direct molecular interaction between the apoE or apoE fragments and tau molecules would require that both meet in the same cytosolic compartment. The question of how apoE accesses the neuronal cytoskeleton remains puzzling. An alternative mechanism in which apoE isoforms

would differentially contribute to tau hyperphosphorylation is the modulation of tau kinases and phosphatases.

1.2.3.4 ApoE, cholesterol and synaptic integrity

The major function of apoE is to redistribute lipids and participate in cholesterol homeostasis. In cultured neurons, cholesterol uptake is lower when the lipid is bound to ApoE4 compared to ApoE2 and ApoE3. ApoE4 is less efficient than other forms in promoting cholesterol efflux from both neurons and astrocytes.¹³³ The structural differences between different apoE isoforms may account for these alterations. In AD, there is a decrease of cholesterol levels in brain and growing evidence indicates that cholesterol itself is involved in AD pathogenesis.¹³⁴ The first indication has come from clinical and epidemiological studies showing that patients with elevated plasma cholesterol levels have increased susceptibility to AD. Several studies have shown that the use of statins, which inhibit the cholesterol synthesis, decreases the prevalence and the progression of AD. In addition to apoE, other genes involved in the transport or in the metabolism of cholesterol have been suggested as putative risk factors for AD. Polymorphisms in receptors for the uptake of cholesterol, such as low-density lipoprotein receptor-related protein (LRP) and the very-low-density lipoprotein (VLDL) receptor, as well as in enzymes that regulate the cholesterol catabolism, such as Cyp46, have been associated with an increased risk for AD.^{135,136} Furthermore, a number of studies suggest that cholesterol regulates the A β production.

β -secretase and γ -secretase are localized in cholesterol-rich lipid rafts, while the non-amyloidogenic α -secretase is associated with the membrane surface outside raft domains. β -secretase activity is increased by cholesterol. In addition, changes in cholesterol levels or distribution within the membrane have been shown to alter the localization of APP and their availability to be cleaved by these secretases.¹³⁷ On the other hand, A β modulates the synthesis and the distribution of cholesterol in neurons. Moreover, it has been shown that cholesterol reduces the effects of A β on calcium signalling and neurotoxicity in several models.¹³⁸ Such data illustrate that the interactions between cholesterol and A β are very complex. Regarding the different ability of variant apoE isoforms for carrying lipids, it is likely that the cholesterol/A β interactions would be modulated by the apoE genotype.

In the nervous system, interaction between neurons and glial cells is very important in processes of growth, regeneration and synaptic plasticity. There, the apoE-mediated redistribution of lipids plays a fundamental role. In AD, there is extensive neuronal loss in the

limbic system and neocortex, as well as an important synaptic dysfunction that affect the normal being of the surviving neurons. It has been suggested that the variant apoE isoforms participate differently in repair processes and synaptic plasticity. Synaptic plasticity in the CA1 region has been found to be impaired in apoE KO mice. ApoE KO and apoE4 but not E3 transgenic mice have an age-dependent disruption of synaptic organization.¹³⁹ These apoE isoform differences have also been reported in humans. ApoE4 carriers show a poor compensation of neuronal loss in different brain regions, whereas non-E4 carriers exhibit marked regenerative changes in the same areas.¹⁴⁰ Such data suggest a lack of function of apoE4 in synaptic regeneration compared with other apoE isoforms. It is likely that this lack of function will also affect synaptic function. Supporting this idea, it has been reported that LTP is reduced in apoE4-transgenic mice compared with wild-type mice and apoE3 mice.¹⁴¹

1.2.3.5 ApoE and cholinergic dysfunction

Cholinergic signal transduction is well known to be impaired in AD. ApoE4 carriers with AD show greater deficits than non-carriers in cholinergic activity in the hippocampus and the cortex, as well as a reduction in the total number of cholinergic neurons markers, such as choline acetyltransferase activity and nicotinic ACh receptor binding. In contrast, there are no significant differences in muscarinic receptor levels between AD patients with different apoE genotypes.¹⁴² Variant apoE isoforms have different effects on ACh muscarinic receptor stimulated signalling in vitro. ApoE4 impaired carbachol-stimulated phosphoinositide hydrolysis, whereas apoE3 alone was without effect.¹⁴³ In addition, ApoE3, but not E4, could protect against A β (1-42)-mediated disruption. In a double transgenic mice model, it has recently been reported that modulation of AD-like cholinergic deficits depends on the apoE isoform, the overproduction of A β , and the age of the animal, but not on plaque deposition.¹⁴⁴ In this study, human APP/apoE4 mice showed synaptic and cholinergic deficits prior to plaque formation. However, old human APP/apoE4 and human APP/apoE3 mice had similar synaptic and cholinergic deficits, despite their differences in plaque load.¹⁴⁴

A direct negative influence of apoE4 on cholinergic signalling may participate in the lower effectiveness of cholinergic replacement treatments reported for apoE4-AD patients.¹⁴²

1.2.3.6 ApoE and signalling

ApoE has been shown to modulate various signalling pathways, some of which are relevant to AD. In several in vitro models, apoE was shown to affect multiple signalling cascades in an

isoform-specific manner. ApoE isoforms differentially influence calcium channels causing different increases in free intracellular calcium. Also, apoE has isoform-specific effects on the activities of PKC, GSK-3¹⁴⁵, Akt, ERK, JNK and on CREB.^{146,147} Recently, a large microarray study with hippocampal samples from AD patients demonstrated that patterns of gene expression differ substantially between have apoE4 and non-apoE carriers.¹⁴⁸ ApoE4 individuals have more expression of tumour suppressors, and negative regulators of cell growth that may lead to increased apoptosis. In contrast, they showed decreased expression of genes associated with synaptic plasticity, neuronal outgrowth, several neurotransmitter receptors, as well as genes involved in mitochondrial oxidative phosphorylation/energy metabolism.

Alteration in neurotransmitter receptors and down-stream signalling may contribute to the development of resistance to some pharmacological therapies seen in individuals with apoE4.¹⁴⁹

1.2.3.7 ApoE and neurotoxicity

ApoE may also contribute to neurodegenerative processes by being directly toxic to neurons. In this context, lipid-free apoE (E4 > E3) and apoE-derived fragments have been shown to be toxic to neurons in vitro.¹⁵⁰ In vivo studies using transgenic mice that express human apoE3, apoE4 or both, have demonstrated that apoE3/E3 animals were more protected than apoE3/4 against age-induced neurodegeneration and that apoE4/4 showed no protection. This would imply that apoE4 is not only less neuroprotective than apoE3, but also acts as a dominant negative factor interfering with the beneficial function of apoE3.¹⁵¹

It has been reported that a N-terminal proteolytic fragment is responsible for apoE toxicity by increasing intracellular calcium levels.¹⁵² Conversely, several reports from another group have shown that the C-terminal fragment of apoE is neurotoxic in vitro by a mechanism that involves mitochondrial and cytoskeletal alterations. In vivo, apoE4 C-terminal fragments were shown to induce neurodegeneration and behavioural deficits in transgenic mice. Importantly, apoE C-terminal fragments were present at much higher levels in the brains of AD patients (especially associated with NFTs) than in controls, although the difference between truncated apoE levels in E3 and E4 carriers was not demonstrated.¹⁵³

In view of the different results obtained with lipid-free or lipid-bound apoE, it is possible that apoE will be more resistant to proteolysis when associated with other lipoproteins or that compositional and/or structural differences of lipoprotein containing apoE particles may be

important for neurodegeneration. Since each apoE isoform possesses structurally defined abilities in lipid binding, it is also important to consider that the composition of lipoprotein particles may differ with apoE genotype. Therefore, it is possible that apoE4 is more susceptible to cleavage than apoE3. Hatters et al. reported that apoE forms soluble fibrillar aggregates in vitro and that the rate of aggregation vary substantially between isoforms (E4 > E3 > E2).¹⁵⁴ ApoE fibrils were significantly more toxic to cultured neuronal cells than the tetramers. Previously, the same group demonstrated that lipid-binding protects apolipoproteins from misfolding into amyloid fibrils, suggesting that the formation of apoE fibrils may require the presence of lipid-free apoE. However, the presence of apoE fibrils (as well as the isoform differential fibrillation) in AD brain has still to be demonstrated. Understanding the factors that govern the apoE neurotoxicity as well as its neuroprotective effects remains crucial for elucidating the role of apoE in neurodegenerative processes.

1.2.4 Other risk and protective factors in AD

Various risk factors have been found to be associated with dementia and/or AD. Identification of risk factors might prove beneficial in preventing AD, since the current treatments have modest effects on symptoms and do not significantly alter the outcome.

Possible risk factors such as a strong association factors (stroke, high blood pressure in mid-life, obesity), moderate factors (depression, diabetes, hyperinsulinemia, excessive alcohol consumption and high cholesterol levels in mid-life) and mild factors (chronic stress, head trauma, low vitamin B12 levels, smoking, saturated fats and cholesterol intake) have been reported.¹⁵⁵⁻¹⁵⁹ Possible protective factors for AD include strong association factors (education and physical activity), moderate factors (leisure activities) and mild factors (moderate alcohol consumption, challenging occupation, eating fish (omega-3) and eating fruits/vegetables (anti-oxidants)).

1.2.4.1 Cerebrovascular disease

Cerebrovascular changes such as hemorrhagic infarcts, small and large ischemic cortical infarcts, vasculopathies all increase the risk of dementia.¹⁶⁰ Stroke may lead to cognitive impairment and AD through several different mechanisms. It is possible that it leads directly to damage of brain regions that are important in memory function. Another explanation might be increased A β deposition, which in turn can lead to cognitive decline. Further, it may induce inflammatory responses that impair cognitive function. Hypoperfusion can lead to

overexpression of cyclin-dependent kinase 5 (CDK5), a serine-threonine kinase that is critical to synapse formations and synaptic plasticity, and, hence to learning and memory.¹⁶¹

1.2.4.2 Blood pressure

In middle age, elevated blood pressure increases the risk of cognitive impairment, dementia and AD. Hypertension may increase the risk of AD by decreasing the vascular integrity of the blood-brain barrier (BBB) resulting in protein extravasation into brain tissue. This protein extravasation can lead to cell damage, reduction in synaptic and neuronal functions, apoptosis and an increase of A β accumulation, resulting in cognitive impairment.¹⁶² Recent studies have evaluated the benefit of antihypertensive treatments in patients with cognitive impairment.^{163,164}

1.2.4.3 Type 2 diabetes

In observational studies, type 2 diabetes (T2D) has been found to nearly double the risk of AD.¹⁶⁵ Various mechanisms have been proposed whereby diabetes might influence the development of AD. In cases of hyperinsulinemia accompanying diabetes, insulin may compete with A β for the insulin degrading enzyme (IDE), thereby hindering clearance of A β from the brain.¹⁶⁶ Moreover, a histopathological study of hippocampal tissue from AD patients and healthy controls showed a relative reduction in IDE expression and *IDE* messenger RNA levels in AD brain tissue.¹⁶⁷ Diabetes and impairment of glucose tolerance lead to the formation of advanced glycosylation end products (AGE_s). Amyloid plaques and NFT_s contain receptors for AGE_s (RAGE_s). Glycation of A β enhances its propensity to aggregate in vitro. In addition RAGE_s may facilitate the neuronal damage caused by A β .¹⁶⁸

1.2.4.4 Plasma lipid levels

Conflicting data are available concerning the relationship between dyslipidemia and cognitive impairment or AD.^{169,170} Amyloid precursor protein (APP) can be broken down by enzymes, termed the secretases, via the nonamyloidogenic and the amyloidogenic pathways. In the second pathway, APP is proteolytically cleaved by β -secretase and subsequently, γ -secretase to generate A β . The most common isoforms of which comprise 40 (A β 1-40) and 42 (A β 1-42) amino acids, with the latter being the most fibrogenic of the two peptide species. Evidence exists that depletion of membrane cholesterol inhibits secretase cleavage of APP, thereby lowering A β 1-40 and A β 1-42 accumulation. Nevertheless, dyslipidemia increases the risk of

vascular disease, which in turn is associated with a heightened risk of AD. In people at risk of cardiovascular and cerebrovascular disease, statins are the first-line treatments for reducing cholesterol levels. The results of a large scale trial of simvastatin to slow AD progression have yet to be published.¹⁷¹

1.2.4.5 Smoking

Smoking could affect the risk of AD via several mechanisms. Smoking may increase the generation of free radicals, leading to high oxidative stress, or affect the inflammatory immune system, leading to activation of phagocytes and further oxidative damage.⁷⁴ In addition, smoking may promote cerebrovascular disease. Evidence also exists, however, that smoking can have a protective effect against AD. Nicotine has been suggested to induce an increase in the level of nicotinic acetylcholine receptors, thereby counterbalancing the loss of these receptors, and subsequent cholinergic deficits, observed in AD.¹⁷²

1.2.4.6 Depressive symptoms

Depressive symptoms occur in 40–50% of patients with AD. Some longitudinal and case–control studies have found an increase in the risk of AD or MCI in individuals with a history of depression, but other studies have been unable to link AD with this mood disorder. The potential mechanisms underlying the possible association between these conditions might involve vascular pathways and effects of depression on the hippocampal formation or the hypothalamic-pituitary-adrenal axis.^{173,174}

1.2.4.7 Psychological stress

Evidence from rodent studies suggests that chronic psychological stress can alter brain morphology (such as hippocampal structure) and, as a result, exert a detrimental effect on brain function, including memory.¹⁷⁵ Thus, chronic psychological stress might increase the risk of AD.

1.2.4.8 Physical and intellectual activity

Epidemiological and experimental data suggest that physical exercise may promote brain health. Conflicting results have emerged from cross-sectional and longitudinal observational studies that examined the relationship between exercise levels and cognitive decline. Some studies indicated that physical activity has a beneficial effect on brain health while others

showed no association between these variables.¹⁷⁶ Physical activity could affect cognition via multiple mechanisms. An improvement in aerobic fitness increases cerebral blood flow, oxygen extraction and glucose utilization.¹⁷⁶ It activates growth factors that promote structural brain changes, such as an increase in capillary density.¹⁷⁷ In addition, studies in rodents suggest that physical activity decreases the rate of amyloid plaque formation.

Following initial reports that elderly people with higher levels of education had a lower incidence of dementia than individuals with no education, cognitive activity was suggested to decrease the risk of cognitive decline by increasing cognitive reserve. Several prospective studies subsequently found that both young and old people who engage in cognitively stimulating activities, such as learning, reading or playing games, were less likely to develop dementia than individuals who did not engage in these activities.^{178,179}

1.2.4.9 Diet

Recent findings show that elderly persons from different ethnicities (for example African Americans and Japanese living in the USA) have higher prevalence of AD than those still living in their countries of origin. This suggests that diet and lifestyle exert more influence than genetics.^{180,181} Several aspects concerning dietary habits as a protective or a risk factor for developing cognitive decline as well as AD are described below.

1.3 DIET AND AD

In 1997, William Grant correlated the amount and type of food consumed in different countries with the prevalence of AD.¹⁸² He found a positive association between total calories, total fat and the incidence of the disease. Kalmijn et al. also noted a correlation between fat intake and dementia in a study of 5400 participants in Rotterdam.¹⁸²

Diets high in fish, fruit and vegetables are high in antioxidants and polyunsaturated fatty acids (PUFAs). In some observational population-based studies, people who had a high intake of vitamins E and C (both antioxidants) were less likely to show cognitive decline and had a lower risk of AD than individuals with a low intake of these vitamins.^{183,184} In contrast, other large prospective studies found no associations between vitamins and the risk of developing AD. Investigations examining the effect of dietary PUFAs on the risk of cognitive dysfunction proved inconclusive.¹⁸⁵ Several studies showed that the consumption of PUFAs led to decreased risk of dementia and cognitive decline, other studies found no association between dietary PUFAs and cognitive impairment.¹⁸⁶ Scarmeas et al. reported that consumption of a Mediterranean-type diet (MeDi) characterized by a high intake of plant foods, fish (with olive oil as the primary source of monounsaturated fat), a moderate intake of wine, a low intake of red meat and poultry reduced the incidence of AD¹⁸⁷ and showed a trend towards reducing the risk of MCI.¹⁸⁸ These effects were independent of levels of physical activity and vascular comorbidity. To date, prospective clinical trial data for dietary supplementation with omega-3 PUFAs have shown no overall effect on cognition in patients with MCI or AD. Although, it suggests that docosahexaenoic acid supplementation has a beneficial effect on cognitive function in people harbouring the apoE $\epsilon 4$ allele and in the earliest stages of AD.^{189,190}

Reactive oxygen species are clearly associated with neuronal damage in AD. However, whether the presence of these molecules reflects a primary or secondary event in the neurotoxic process remains unclear. Depositions of A β , which is an early event in AD leads to a decrease in cerebral iron and copper concentrations, resulting in oxidative stress and neuronal damage.¹⁹¹ Evidence from in vitro studies indicates that vitamin E reduces the extent of A β -induced lipid peroxidation and cell death.¹⁹² In addition, carotenes and vitamin C protect against lipid peroxidation. Furthermore, vitamin C reduces the formation of nitrosamines and may affect catecholamine synthesis.¹⁹³ Evidence also exists that antioxidant intake reduces the risk of AD through a reduction in the risk of cerebrovascular disease.¹⁹⁴

Besides reducing oxidative stress, PUFAs have positive effects on neuronal and vascular functions as well as inflammatory processes.¹⁹⁵

1.3.1 High saturated fat diet and AD

The presence of saturated fats in our diets may affect memory function and possibly increase people's risk of developing AD.¹⁹⁶ Much, but not all of the evidence comes from animal studies. In these studies, mice and rats were fed with diets of different fat levels and then tested for learning and memory. The animals fed with a high proportion of saturated fat displayed worse learning and memory than those on the lower-fat diet. In one study performed on rats, investigators examined whether the adverse effects were from saturated fat specifically, or from any fat at all. One group of rats was fed coconut oil, known for its high saturated fat content for eight weeks. Another group was fed soybean oil, low in saturated fat and high in unsaturated fat for the same amount of time. After eight weeks the animals fed the coconut oil had higher triglycerides, higher total cholesterol, and higher low-density lipoproteins. The rats fed the diet high on soybean oil did much better on memory and learning tests than did the rats fed the diet high in saturated fat.¹⁹⁷ In another study, transgenic mice were fed a diet high in saturated fat and cholesterol with a control group of mice who did not receive the fatty diet. After two months, the mice were tested for memory-related tasks. Those that had been fed the diet of saturated fat were not able to remember the tasks, but the control group could perform them.¹⁹⁸ In another study, when brains of rats were examined, researchers found increased levels of the toxic amyloid- β protein in the mice fed the high-saturated-fat diet, and this might be altered by a ketogenic diet.¹⁹⁹ These data suggest a link between diets high in saturated fat and the development of AD changes in the brain. Researchers found that people who were apoE ϵ 4 carriers and who had a high intake of saturated fat had an increased risk for the development of AD when compared with ApoE4 carriers who had a lower intake of saturated fat. On the other hand, the intake of unsaturated fats did not appear to influence the development of AD among ϵ 4 carriers and noncarriers.²⁰⁰ However, researchers in the Rotterdam population study found no cross-sectional association between high levels of saturated fat intake and an increased risk of dementia, so that what seemed to be a clear link in the rat and mice studies was not confirmed by clinical observations.¹⁸⁶ High fat diets appear to interfere with glucose tolerance and insulin sensitivity, and again have different effects depending on the type of fat.²⁰¹ The risk of type II diabetes is also associated with a high trans-fatty acid intake and a low unsaturated/saturated

fat intake ratio.²⁰² There are reports that saturated and trans-fatty acids increase insulin resistance, whereas mono- and poly-unsaturated fats decrease resistance and offer protection against disease.²⁰³ Therefore, the detrimental effect of a prolonged high fat diet on cognitive performance may, at least in part, be due to abnormalities in glucose regulatory mechanisms.

1.3.2 Cholesterol and AD

A strong correlation between high fat/high cholesterol diets and increased brain A β levels has been shown in numerous experimental animal models. These studies demonstrate that an inappropriate diet rich in cholesterol is likely to increase the risk of AD. For example, in rabbits with diet-induced hypercholesterolemia, increased levels of A β and apoE protein have been found in the temporal and frontal cortex of the brain.²⁰⁴ In Watanabe rabbits with a genetic defect in the LDL receptor, both hypercholesterolemia and neuronal A β deposition occur.²⁰⁵ AD transgenic mouse models develop A β plaque-like deposits more quickly if fed a high fat /high cholesterol diet. The levels of brain A β in these mice correlate strongly with both plasma and CNS total cholesterol levels.²⁰⁶ In contrast, caloric restriction decreases A β peptide generation and neuritic plaque deposition in the brains of such mouse models.²⁰⁷ Interestingly, guinea pigs fed a high cholesterol diet show increases in plasma but not brain cholesterol levels. Many clinical studies, as well animal studies such as those mentioned above have shown that high fat/high cholesterol diets lead to increases in brain A β levels and to HDL/cholesterol and LDL/cholesterol levels linked to AD. Therefore, it is understandable that obesity is now also recognized as an important risk factor for AD.²⁰⁸

A β , apoE, cholesterol, and cholesterol oxidase have been shown to colocalize in the core of fibrillar plaques in transgenic mice models of AD,²⁰⁹ supporting the suggestion that cholesterol and apoE are involved in fibrillar plaque formation. Cholesterol may be directly involved in A β aggregation: abnormal oxidative metabolites such as cholesterol-derived aldehydes can modify A β , firstly promoting Schiff base formation, then accelerating the early stages of amyloidogenesis.²¹⁰ Other studies have shown that a novel A β species, having a conformation distinct from that of soluble A β , is characterized by its tight binding to GM1 ganglioside (GM1). This binding appears to be facilitated in cholesterol-rich environments and is dependent on the cholesterol-induced clustering of GM1 in the membranes. The changes in HDL- and LDL-cholesterol levels in AD suggest a disturbed cholesterol metabolism in AD. The cholesterol metabolite 24S-hydroxycholesterol is more soluble than

cholesterol, and is more easily exported from the brain.²¹¹ The amount of 24S-hydroxycholesterol exiting the brain is thought to reflect brain cholesterol synthesis levels, and CSF 24S-hydroxycholesterol levels are higher in AD individuals when compared with appropriate controls.²¹² However, in severe cases of AD, plasma 24S-hydroxycholesterol/cholesterol ratios have been found to be reduced.²¹³ Cholesterol is converted to 24S-hydroxycholesterol by cholesterol 24-hydroxylase encoded by the CYP46 gene, and it has been suggested that its levels may play a role in AD.²¹² Some studies have found CYP46 gene polymorphisms are associated with AD pathophysiology,²¹⁴ however others have found CYP46 polymorphisms not to affect AD risk.^{215,216}

Cholesterol can be synthesized in the brain, therefore brain cholesterol homeostasis may be independent from the periphery.²¹⁷ In support of this, dietary levels of cholesterol have marked effects on de novo peripheral cholesterol synthesis, yet appear to have little or no effect on brain cholesterol synthesis or metabolism.²¹⁸ In addition, although one study has found that LDL can cross the blood-brain barrier (BBB) by receptor-mediated transcytosis,²¹⁹ most studies suggest that plasma lipoproteins do not cross the BBB. In AD, brain cholesterol flux is elevated: when compared to controls, higher levels of the more soluble form of cholesterol, 24S-hydroxycholesterol, are found in both CSF and plasma of AD patients, even in early stages of dementia, although the cause of this is unknown. AD patients respond positively to cholesterol-lowering drugs. This underscores the relevance of cholesterol metabolism in AD, despite the fact that brain cholesterol levels are not necessarily affected by the drugs.

1.3.3 High carbohydrate diet and AD

High carbohydrate diet and possession of apoE4 suppress the lipid metabolism in a similar manner and in combination greatly increase the risk for AD. Since E4 and high carbohydrate diet inhibit lipid metabolism in a similar way, this may explain the natural selection against E4 in long-time agricultural societies when intake of carbohydrates in the diet became higher. Prior the development of agriculture, E2, E3 and E4 may have been neutral alleles that arose when human ancestors began to eat more animal matter and hence more fat. This led to a selection of apoE. The development of agriculture then imposed a new selection on apoE reducing E4 in Middle Eastern and Mayan populations.²²⁰

The high carbohydrate diet leads to high glucose serum levels, induces lipogenesis and hypertriacylglycerolemia. This would be worsened by possession of E4 allele. Therefore, E4

allele in combination with an high carbohydrate diet could be deleterious. Population with little exposure to high carbohydrate diets have higher E4 frequencies suggesting that there was no selection against E4 in these conditions.^{221,222} Further, having the E4 allele may not be a risk factor for AD in all population.⁹⁷ Nigerians who eat considerably less high-glycemic carbohydrates than US show a low incidence of AD despite the relative high frequency of E4. ApoE4 and high carbohydrate diet contribute to decreased lipid metabolism in the central nervous system, altering the function of glucose transporters and APP. This leads to a chronic elevated insulin/IGF signaling. The combination of the increase of insulin signaling (a consequence of the diet) and the action of ApoE4 (that preferentially binds triglyceride rich particles such as VLDL and chylomicrons, with consequent decrease of lipoprotein lipases activity) leads to the decrease of free fatty acid use and of essential fatty acid delivery to the CNS. This compromises the integrity of cellular membranes and the function of membrane proteins such as glucose transporters and APP. Decrease in glucose uptake leads to lower level of acetyl-Coenzyme A and Acetylcholine. A consequence of lower acetyl-Coenzyme A levels is alterations in cholesterol homeostasis. An important protein, sensitive to disturbances in cholesterol homeostasis is APP. The final results of all these processes will lead to A β accumulation, cellular damage and cell death.

Several evidences indicates that excess consumption of carbohydrates plays an important role in the epidemic of obesity around the world.²²³ Numerous epidemiologic studies suggest that obesity, hyperinsulinemia and type II diabetes are associated with an increased risk of AD, independent of the risk for vascular dementia.

1.3.4 Insulin-signaling pathway

Adiposity, hyperinsulinemia, glucose intolerance and diabetes are often treated as separate constructs and have been separately related to the risk of AD. However, they are related sequentially and often occur simultaneously. Understanding this relation is fundamental in the study of the role of adiposity and metabolic risk factors in AD. Glucose intolerance and diabetes are abnormal elevation of blood glucose. Glucose normal levels are achieved by the balance between the ability of peripheral tissues to take glucose into cells and the pancreas ability to secrete insulin. Insulin is the hormone in charge of glucose tissue uptake. Thus, abnormal glucose levels are caused by a resistance of tissues to the action of insulin (insulin resistance) and by the pancreas inability to secrete enough insulin at normal levels. It can also be caused by higher than normal insulin levels (hyperinsulinemia) to overcome insulin

resistance in tissues. The greatest determinant of insulin resistance and hyperinsulinemia is adiposity. One of the main consequences of adiposity is hyperinsulinemia.

The role of insulin in AD has attracted increasing attention. Insulin can cross the blood brain barrier from the periphery to the central nervous system and compete with A β for insulin degrading enzyme in the brain, including the hippocampus. Insulin is also produced in the brain and alternatively may have a beneficial effect in amyloid clearance. Hyperinsulinemia may inhibit brain insulin production which in turn results in impaired amyloid clearance and a higher risk of AD. A study found that rosiglitazone, which decreases insulin resistance and decreased peripheral insulin levels used in the treatment of diabetes may also be beneficial in AD. Hyperinsulinemia is related to a higher risk of AD in epidemiological studies.¹⁵⁸ Manipulation of insulin levels in humans has been demonstrated to affect cognition and levels of A β in the cerebrospinal fluid, supporting the potential direct role of insulin in AD. Subgroups of patients with advanced Alzheimer's disease have high fasting insulin levels and low rates of glucose disposal (peripheral resistance).²²⁴ Levels of insulin receptors, glucose-transport proteins and other insulin pathway components in the brain are reduced in some studies of Alzheimer's disease (central resistance).²²⁵

Insulin and brain-derived insulin-like-growth factor (IGF) are extracellular ligands that regulate metabolic activity and activate many of the same intracellular signaling cascades as neurotrophins.⁷⁸ While insulin is not a classic neurotrophic factor, it exhibits many neurotrophic and protective effects on neurons. Endogenous insulin signaling is important for maintaining relatively low phosphorylation levels of Tau and downregulation of insulin signaling may be a factor leading to Tau hyperphosphorylation levels and cytoplasmic aggregation in AD. In general, insulin signaling and metabolism is reduced in the aging brain, regardless of disease pathology. Resistance to insulin signaling renders neurons energy-deficient and vulnerable to oxidizing or other metabolic insults and impairs synaptic plasticity. Moreover, the higher serum glucose levels that are common in normal aging directly damage hippocampal structures²²⁶, up-regulate the tau kinase, GSK-3 β ²²⁷ and reduce levels of insulin-degrading enzyme in AD brains.¹⁶⁷ Therefore, decreased insulin signaling may increase other genetic and environmental factors to induce AD disease progression. Importantly, apoE4 has been found to modulate the effect of other risk factor, such as diabetes and hyperinsulinemia.²²⁸

1.3.5 Adipokines and cytokines

Adipose tissue used to be conceived as a passive storage of energy in the form of fats. Recent evidence shows that adipose tissue is active and produces a series of substances that are important in metabolism (adipokines) and inflammation (cytokines). The adipokines (adiponectin, leptin and resistin) and the inflammatory cytokines (TNF α and IL-6), all correlated with insulin resistance and hyperinsulinemia. At this point it is unclear if adipokines and cytokines produced by adipose tissue are directly related to AD or only markers of insulin resistance and hyperinsulinemia. Recently, it has been reported that leptin has widespread actions in the central nervous system. Leptin reduces the activity of beta secretase in neurons and increases APOE dependent uptake of A β in vitro. Chronic administration of leptin in AD transgenic mice can decrease brain A β in vitro, supporting a potentially important role for adipokines in AD, in addition or independent of insulin.²²⁹

1.3.6 Leptin

The hormone leptin was originally discovered in 1994. The primary amino acid sequence of leptin indicates that leptin adopts a three-dimensional helical structure similar to that of certain cytokines, such as interleukin-2. The 16 kDa protein, encoded by the obese (*ob*) gene²³⁰ is mainly synthesized in adipose tissue. It was first linked to obesity by demonstrating its function in controlling body mass size via inhibition of appetite behaviours.²³¹ Circulating leptin serves to communicate the state of body energy repletion to the central nervous system in order to suppress food intake and permit energy expenditure. Leptin is taken into the brain across the blood brain barrier (BBB), where its main functional role is in the hypothalamus, inhibiting the arcuate nucleus. In addition to its main role in feeding and homeostatic energy control, leptin is now known to exert significant effect on reproduction²³², thermogenesis²³³, insulin sensitivity²³⁴, synaptic plasticity²³⁵ and more recently neuroprotective activity in several brain regions.²³⁶

Adipocytes are the major leptin-producing organ in the periphery. Peripheral leptin can be bound in the serum by soluble leptin receptor and/or taken up across the BBB. The amount of leptin that crossed the BBB is much less than what is found in the periphery. The transport across the BBB is proposed to be saturable and the transport of leptin is unidirectional, from the blood into the brain parenchyma. Any excess of leptin is cleared via the CSF.²³⁷ In addition to adipose tissue, it is known that leptin is also synthesized by other tissue and organs: placenta, fetus, skeletal muscle, heart and stomach. There is also evidence for leptin

synthesis in the brain itself. In rats, brain regions that contain high levels of leptin receptors, also show leptin mRNA and protein.²³⁸ It is yet to be determined if leptin produced endogenously by the brain is functionally independent from that produced in the periphery. Since the concentration of leptin is considerably low in the CSF even after exogenous supplementation, an endogenous source of leptin production may provide signaling that is more relevant to brain areas outside of the hypothalamus.²³² Endogenous synthesis and release of leptin in the brain itself might help to explain how localized leptin production could be involved in promoting the survival of neurons. Although, there is some evidence that leptin could be synthesized within the brain, it is believed that the majority of leptin in the CNS is derived from peripheral adipose tissue. Evidence has been provided for a specific transport system for leptin to cross the blood brain barrier and enter in the brains of mice, rats and humans. The rate of transport can be decreased by high plasma concentration of leptin. Thus, reduced entry of leptin to the brain may be one of the mechanisms of reduced sensitivity of the leptin pathway in obese individuals. Decreased availability of leptin to the brain is now known to be the basis for obesity. Obese individuals often have highly elevated blood levels of leptin in response to the increase of adipocyte mass. These high levels would be expected to depress appetite, but leptin fails to do so. Experiments demonstrate that triglycerides can reduce leptin transport across the BBB and can be one of the reasons that create a form of leptin resistance.²³⁹ This explains the failure of exogenously administered leptin as treatment for obesity in some individuals, since leptin is prevented from entering the brain.

Functional leptin receptors have been found in many regions of the brain. The ventral hypothalamus, in particular the arcuate nucleus has the greatest density of leptin receptors.²⁴⁰ The high numbers of leptin receptors correlate with the functional role of leptin in regulating feeding and energy homeostasis. Leptin receptors are abundantly expressed in other brain regions, including cortex, thalamus, cerebellum, midbrain and hippocampus (primarily in the dentate gyrus and CA1, areas heavily affected in AD). This finding demonstrates that leptin is biologically active in extra-hypothalamic regions.

There are six forms of the leptin receptors (ObR).²⁴¹ The Ob receptors are members of the interleukin-6 receptor family of the class I cytokine receptor super family. Ob receptors are classified in three structural groups: the short, the long and the soluble forms. The external leptin-binding N-terminal is identical among all variants. All forms contain a transmembrane domain, except the soluble form which only contain extracellular domains that binds circulating leptin. This might regulate the concentration of free leptin.²⁴² The long form

contains three additional phosphorylation sites on its intracytoplasmic tail, compared to the short form. It is thought that many of the physiological actions mediated by leptin are due to the long form receptor because of its greater ability to activate downstream signaling pathway. The short form receptors appear to be important in mediating the transfer of leptin from the periphery through the BBB.

Intracellular signaling of ObR is similar to the class I cytokines. Leptin receptors share several signaling cascades with insulin and erythropoietin receptors. This class of receptors has no intrinsic enzymatic activity of their own. After ligand binding, ObR associate as functional homodimers. This allows its associated second messenger Janus tyrosine kinase 2 (JAK2) to undergo activation, autophosphorylation and contribute to several different cascades. One of its major actions is to phosphorylate three tyrosine residues on the intracytoplasmic loop. The phosphorylation of one of these three residues activates MEK/ERK signaling pathway. This pathway is also shared with insulin, leading to stimulation of BDNF production, via phosphorylation of the transcription factor cAMP-response element binding (CREB). The major element that JAK2 phosphorylates is the transcription factor signal transducer and activators of transcription 3 (STAT3). Activation of STAT3 includes its dimerization, which then allows it to translocate to the nucleus and affect the transcription of a number of factors. These factors mediate neuronal activity, survival and a negative feedback loop on JAK2 activity via suppressor of cytokine signaling 3 (SOCS3).^{243,244} SOCS3 itself binds to the phosphorylate tyrosine residue Tyr 985 to attenuate the receptor signaling.¹²⁸ In addition leptin can evoke an increase response via activation of the mitogen-activated protein kinase (MAPK) and phosphatidylinositol (PI3K) pathways. This response reduces GSK-3 activity and consequently may decrease tau phosphorylation. AMP activated kinase may also mediate leptin signaling, leading to an increase in ATP with consequent increase glucose uptake, lipolysis and inhibition of lipogenesis.^{245,246}

Recent studies have demonstrated the potential beneficial effects of leptin as an AD therapeutic.²⁴⁷ In vitro studies have reported that leptin treatment of neuronal cells reduces the amount of A β secreted into the medium in a time and dose-dependent manner. This effect was coincident with a change in the lipid profile of membranes affecting lipid rafts and reduction of β -secretase activity. This may be attributed to the lipolytic action of leptin which could also explain the ability of leptin to facilitate the lipoprotein receptor-like protein (LRP)-dependent uptake of ApoE/A β complexes, a mechanism for clearing A β .²²⁹ Moreover, an abnormal accumulation of lipids in non adipocytes may favour amyloidogenic pathways, which can be

prevented if sufficient leptin is present. It was demonstrated that leptin treatment can lead to a reduction in tau phosphorylation through the modulation of AMPK and GSK-3 β , without any observed toxicity. Specifically, leptin reduces the amount of phosphorylation at Ser²⁰², Ser³⁹⁶ and Ser⁴⁰⁴, all sites which are phosphorylated in NFTs.^{248,249} A similar activity has been reported for insulin. Thus, leptin is capable of modulating both the production of A β and phosphorylation of tau, two main pathological hallmarks of AD. Further, leptin deficient mice have different synaptic profiles from wild type mice. Administration of leptin rapidly normalized synaptic function.²⁵⁰

Recently, it was shown that direct injection of leptin into the hippocampus of rodents can improve memory processing and modulate long term potentiation and synaptic plasticity. Leptin rapidly enhances NMDA-induced increases in intracellular calcium levels and facilitates NMDA receptor-mediated synaptic transmission.²³⁵ Leptin promotes rapid alterations in hippocampal synapses, which are likely to contribute to leptin-driven changes in excitatory synaptic strength.²⁵¹ Studies performed in obese leptin-insensitive rodents have detected deficits in hippocampal synaptic plasticity and in spatial memory tasks performed in the Morris Water Maze.²⁵² Prolonged leptin treatment of CRND8 transgenic mice (animal model of AD), can lower A β levels in brain extracts. The CRND8 mice overexpress the A β PP gene containing the Swedish and the Indiana familial AD mutations. They exhibit early-onset, progressive cognitive deficits and amyloid plaques deposition starting from 3 months of age, providing a robust model to study potential therapeutic effects. Leptin-treated transgenic mice showed significantly reduced levels of A β in brain and serum. In addition, reduction of the amyloid burden in hippocampus was observed. The decrease of level of A β in the brain correlated with a decrease in the levels of C99 C-terminal fragments of the A β PP. This is consistent with the role of leptin in mediating the effect of β -secretase. In addition the treated mice showed a reduction of phosphorylated tau in Ser³⁹⁶. After the chronic treatment, no inflammatory response was observed. Moreover, biochemical and pathological changes were correlated with cognitive improvements in memory tests.²⁵³ Improved memory following leptin administration was also found in SAMP-8 mice, an accelerated senescence rodent model that develops amyloid plaques.

More recent studies provide support for a link between impaired and/or altered leptin function and the development of AD. Indeed, circulating concentrations of leptin are reported to be significantly lower than normal in individuals with AD and in murine models of AD. However it is not known if the circulating levels of leptin in healthy individuals show any

correlation with the risk of developing AD later in life. In a recent prospective study²⁵⁴, the plasma concentrations of leptin were evaluated in 785 individuals from the original Framingham study cohort²⁵⁵. This was performed to determine if the baseline plasma concentration of leptin relate to the incidence of AD. All the individuals were periodically assessed for impairments in cognitive function and dementia. A subset of 200 individuals underwent magnetic resonance imaging (MRI) investigation of the brain. Two markers of early AD were evaluated, the temporal horn volume (an inverse measure of hippocampal volume) and the total cerebral brain volume. The main findings of this prospective study are that higher plasma concentration of leptin correlated with a significantly lower risk of dementia and AD. This correlation was independent of vascular and neurodegenerative risk factors. Furthermore, data from the MRI study indicates that higher leptin concentration in plasma correlated with larger cerebral brain and hippocampal volumes. Thus suggest enhanced cognitive function in individuals with higher leptin levels. Together these epidemiological findings support the concept that the risk of AD is significantly lower in individuals with higher leptin concentrations. In this study, Lieb et al found that plasma leptin was significantly higher in women compared to men. It is well known that the incidence of AD is significantly higher in the female population. Thus, it needs to be understood why the incidence of AD is not significantly lower in female population given to the higher leptin plasma levels in females. Further research is needed to test the hypothesis that higher leptin levels protect against cognitive diseases, especially in obese individuals. Circulating concentrations of leptin are correlated with body fat content. It is well established that in obese individuals leptin levels are increased and resistance to the hormone develops. In this study, because of the small number of obese individuals, no significant association could be found between leptin levels and AD. Statistical significance was found only in non obese individuals. Obese individuals, in spite of their hyperleptinemia, might not be protected from developing AD, possibly because of high leptin resistance in the brain. If high leptin levels do not promote satiety in obese individuals, it might be possible that they do not promote neuroprotection. If neuroprotection is not achieved by hyperleptinemia in obese individuals, the underlying molecular mechanisms may be the same as those that cause neuronal resistance to leptin's satiety effects. It is critical to determine whether or not the central leptin resistance obesity affects its potential neuroprotective effects. Therefore, it is believed that caution is needed in the interpretation of epidemiological studies shown by Lieb et al. Additional studied are needed to elucidate the molecular mechanism by which leptin might be

protective for developing AD.²⁵⁶ There are still several questions that remain unanswered, such as the mechanism by which high circulating levels of leptin protect from developing AD and the stage of the disease process at which leptin acts.

All these findings point out the importance of leptin in Alzheimer's disease and reinforce the importance of this hormone as a link between adipose tissue and brain. Metabolic pathways have been shown to be very important in AD, thus need further investigation. The effect of diet and nutrition on the prevalence of AD have been documented and weight loss is frequently observed prior to the onset of dementia.²⁵⁷ Further, central obesity is associated with an increased risk for developing dementia. Another important risk factor connected to obesity is ApoE4 gene. Carriers of the ApoE4 gene are at a higher risk for developing AD later. In cell cultures and animal models it has been demonstrated that lipids play an important role in amyloidogenic pathways. The majority of AD patients have some form of insulin resistance, hyperinsulinemia or type-2 diabetes. For all these reasons, it is not surprising that modulators of cholesterol (statins) and glucose (rosiglidazone) are being developed as potential AD therapeutics. In fact, cholesterol-reducing therapies such as statins have been shown to reduce A β deposition both in vivo and in vitro. The underlying mechanisms of leptin appears to be substantially unique and show potential therapeutic effects.

1.4 THERAPY FOR AD

Although basic research in AD has made remarkable progress over the past two decades, currently available drugs can only improve cognitive symptoms temporarily. No treatment can reverse, stop or even slow this inexorable neurodegenerative process. The mainstays of conventional pharmacotherapy for AD are compounds aimed at increasing the levels of acetylcholine in the brain, thereby facilitating cholinergic neurotransmission through inhibition of the cholinesterase. These drugs, known as acetylcholinesterase inhibitors were first approved by the US FDA in 1995.²⁵⁸ Only four of them are approved so far: donepezil, galantamine, rivastigmine and tacrine. In 2004, the FDA approved memantine, an NMDA antagonist for treating dementia symptoms in moderate-to-severe AD cases.²⁵⁹ They offer primarily symptomatic benefits, providing temporary cognitive improvement and deferred decline but with little or no evidence of slowing disease progression.

Characterization of the underlying pathophysiology of AD suggests targets for potential disease-modifying treatments. Neurotrophic factors (including hormone replacement therapy and drugs acting on insulin signal transduction) and anti-amyloid agents (including

cholesterol-lowering therapy) are in Phase III clinical trials.²⁶⁰ The increased occurrence of insulin resistance in AD and the numerous mechanisms by which insulin may affect clinical and pathological aspects of the disease suggest that improving insulin effectiveness may have therapeutic benefit for patients with AD. Herbal drugs, such as epigallocatechin gallate, curcumin and resveratrol, well known antioxidants have shown potential effect in preclinical studies. In recent years, the proclivity of cannabinoids to exert a neuroprotective influence has attracted substantial interest as a means to mitigate the symptoms of neurodegenerative conditions. Drug candidates that inhibit tau kinases, such as GSK-3 β and CDK5, should shortly be entering clinical trials. This approach has recently been tested in a rodent model of AD exhibiting both plaque and NFT pathology. Although treatment with lithium, an inhibitor of GSK-3 β , led to a reduction in tau pathology, there appeared to be little effect on the A β loads.²⁶¹ This observation highlights a wider issue which is that successful treatment of AD may require a combination of therapies specifically targeting the various pathologies observed. These approaches hold promise for disease modification and cognitive enhancement.

2. AIM OF THE STUDY

Alzheimer's disease is a multifactorial disease, probably caused by both genetic and environmental risk factors. The overall aim of this thesis is to investigate the effects of the interaction between apoE genotype and life style related risk factors in the pathogenesis of AD. The work has concentrated on apoE4 genotype, diet and leptin. The focus has been on behavioural studies and neurodegenerative processes at molecular level.

Specific aims:

ApoE4 and diet

- 1) To characterize the onset of cognitive decline of apoE3 and apoE4 target replacement mice and to investigate the influence of diet (high saturated fat and high carbohydrate diet vs. normal diet) on the different apoE genotypes. The animals were examined for learning and memory deficits in spatial reference and contextual learning tasks, involving hippocampus and amygdala respectively.
- 2) To define the molecular trigger for the first observable cognitive changes in this animal model focusing on synaptic integrity, tau phosphorylation and APP processing.

Leptin

- 1) To clarify the function of leptin in the pathogenesis of AD through studies in vitro, in mice and human.
- 2) To investigate if apoE genotype affects leptin levels and signaling.

3. MATERIALS AND METHODS

3.1. ANIMALS

In order to explore the impact of different risk factors in relation with the *apoE* genotype on neurodegeneration we used as animal models, human *APOE* Target Replacement (TR) Model mice expressing human apoE3 and apoE4, under the control of the murine apoE regulatory sequences and on the C57BL/6J background. ApoE3 and apoE4 TR mice were purchased by Taconic Farms (USA):

Homozygous B6.129P2-*ApoE*^{tm3(APOE*4)Mae} N8

Homozygous B6.129P2-*ApoE*^{tm2(APOE*3)Mae} N8

The model was created by targeting the murine apoE gene for replacement with the human APOE4 and APOE3 allele in E14TG2a ES cells and injecting the targeted cells into blastocysts. Resultant chimeras were backcrossed to C57BL/6 for seven generations (N7). The mice were backcrossed once more (N8) and embryo transfer derived. The colony is maintained through mating homozygotes. Four ApoE4 and ApoE3 male and eight ApoE4 and ApoE3 female mice were bought and the colony was maintaining by homozygous breeding. Research Breeding Agreement was delivered by Taconic Farms. Once we obtained the sufficient number of animals for the experimental design, the pups were divided in 6 groups of male mice. They suckled by mothers fed with different diets and after the milk phase, they were kept on the following diets (Mucedola srl, Milano):

- normal diet, ND (n= 13-17 per genotype)
- high cholesterol and saturated fats diet: 5% cholesterol, 10% of soybean oil, HC (n= 13-17 per genotype)
- high carbohydrate diet: 70 % of carbohydrates, HS (n= 13-17 per genotype)

The mice were housed in individually micro isolation cage rack (Tecniplast, Italia) with water and laboratory chow ad libitum and controlled conditions of light (from 7.00 a.m. to 7.00 p.m.), temperature (22±2 °C) and humidity (65%). The experimental protocol was approved by a local bioethics committee, while the procedures and animal comfort were controlled by the University Veterinary Service. All efforts were made to minimize animal suffering and the number of animals used was kept to a minimum by the experimental design. The table n.1 shows the number of mice for each genotype, diet and age.

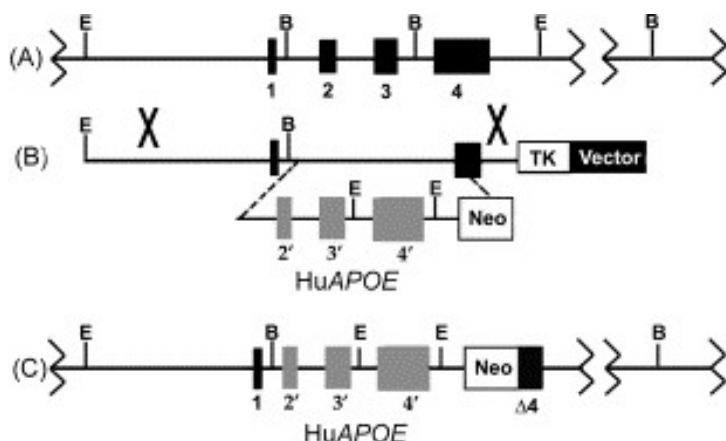

A) Genomic organization of the mouse apoE gene containing exons 1–4 (black boxes). B) The human *APOE* targeting constructs containing the 5' and 3' arms of mouse homology (black line and boxes) interrupted by the human *APOE* gene (hatched boxes 2'–4'). The neomycin-resistant (Neo) and thymidine kinase (TK) genes are for selection of the targeted embryonic stem cells, and pPNT is the plasmid vector. C) The resulting chimeric gene now encoding human *APOE*. Diagnostic restriction enzyme sites for genotyping are shown: E, *EcoRI*; and B, *BamHI*.

Table 1. Number of mice within each genotype, age and diet.

DIET	Age (month)	WT	APOE3	APOE4
ND	6	15	16	14
	13	14		10
HS	6	14	17	13
	13			10
HC	6	15	16	14
	13			10

3.2 BEHAVIOURAL TESTING

The sequence of behavioural testing was Morris water Maze and passive avoidance. This order of testing was used to begin with the least stressful tests and end with those thought to be most stressful.

3.2.1. Morris Water Maze

Mice were trained in the reference memory version of the Morris water maze task²⁶² to locate an hidden escape platform in a circular pool. The apparatus consisted of a large circular tank (1.89 m diameter, 70 cm height) with a transparent escape platform (10 cm²). The pool was virtually divided into four equal quadrants identified as northeast, northwest, southeast, and southwest. The tank was filled with water up to 1.5 cm above the top of the platform and

water was made opaque with milk and kept at a temperature of $20 \pm 2^{\circ}\text{C}$. The platform was placed in the tank at a fixed position constant position (in the middle of the northwest quadrant) during all training sessions. The pool was located in a large room with a number of extra-maze visual cues, including geometric images (squares, triangles, circles) hung on the wall, diffuse lighting, curtains to hide the experimenter and the awaiting mice. Mice (N=134) were assigned to five testing groups using a randomized block design. Each mouse was given 6 trials a day for 4 consecutive days with an inter-trial interval (ITI) of 30 minutes. Mice were released facing the wall, from one of four possible starting points and allowed to search up to 120 seconds for the platform. During each day the starting position remained constant. Irrespective of trial performance mice were guided to the platform and allowed to remain there for at least 15 seconds. Retention was measured on the fifth day after 24 hours using only one starting point. A video camera was set above the center of the pool and connected to a video-traction system that analyzed the information. Swimming patterns were recorded using Ethovision 3.0 © (Noldus Information Technology B.V., Wageningen, Netherlands). The latency time of the first occurrence to the platform was calculated and used as a measure of learning. Latency time, the total time spent in the quadrant in which the platform had been located during training and the number of times the animal crossed the platform location served as measures of retention of acquired spatial learning. The average swim speeds were also analyzed. All training sessions were carried out between 09.00 and 15.00 h.

3.2.2 Passive Avoidance

Emotional learning and memory were assessed in a passive avoidance test. The instrument consists of a tilting-floor box (47x18x26 (h) cm) divided into two compartments by a sliding door and a control unit incorporating a scrambler shocker (Ugo Basile, USA). This classic instrument for Pavlovian conditioning exploits the tendency in mice to escape from an illuminated area into a dark one (step-through method). The firsts day mice were individually placed into the illuminated compartment. After 60-seconds of acclimation period, the connecting door between the chambers opened. In general, mice step quickly through the gate and enter the dark compartment because mice prefer to be in the dark. Upon entering the dark compartment, the mice received a brief foot shock (0.3 mA for 3 seconds) and were immediately removed from the chamber. If the mouse remained in the light compartment for the duration of the trial (300 seconds), the door closed and the mouse was removed from the light compartment. The chambers were cleaned with 70% ethanol between testing of

individual mice. After a 24 hours retention period, the mice were placed back into the light compartment and the time to re-enter the dark compartment (latency) was measured up to 300 seconds. No shock was administered during the testing phase if the mouse entered the dark compartment before 300 seconds had elapsed. The latency time to re-enter the dark compartment 24 h later was measured.

3.3 TISSUE PREPARATION

After behavioural studies, mice were killed by cervical dislocation and their brains were quickly removed. Brain tissue, blood and liver were collected. Brains were sectioned longitudinally: half brain, dissected in several areas such as frontal cortex, hippocampus, hypothalamus and striatum, was used for immunoblotting and frozen and stored at -80°C. The other half was post-fixed in 4% paraformaldehyde in 0.1 M PBS pH 7.4 solution for 72 hours for immunohistochemistry studies.

3.3.1. Immunoblotting

The dissected brains were homogenized in lysis buffer (50 mM Tris-HCl pH 7.5, 150 mM NaCl, 1% Triton X-100, 2 mM EDTA, 2 mM EGTA) with protease and phosphatase inhibitor cocktail (Sigma-Aldrich, MO) at dilution 1:500 added freshly, and incubated 30–60 minutes on ice before centrifugation (13600g for 10 min) at 4°C. Samples were mixed with equal volume of tricine gel sample buffer (0.16 M Tris-HCl pH 6.8, 4% SDS, 20% glycerol, 0.01% bromophenol blue, 0.1 M DTT added fresh) and then SDS-PAGE and immunoblotting was performed. Protein levels were quantified using the BCA protein assay kit (Pierce, Rockford, IL, USA). Equal amounts of protein were separated using 10% acrylamide gel and the proteins transferred to a nitrocellulose membrane (Schleicher & Schuell, Germany). Incubation with primary antibodies (Table 2) was performed overnight, followed by incubation with anti-rabbit or anti-mouse immunoglobulin G (IgG) at 1:2000 dilution (Amersham Biosciences, Little Chalfont, UK). Immunoreactivity was detected by the ECL detection system (Amersham Biosciences, Little Chalfont, UK). Some immunoblots were stripped using Restore™ Western Blot Stripping buffer (Pierce, Rockford, IL, USA) at room temperature for 15 minutes, and then re-blotted with other antibodies. The relative density of the immunoreactive bands was calculated from the optical density (OD) multiplied by the area of the selected band using ImageJ 1.383 software (NIH, MA).

Table2. List of primary antibodies

Antibody	Company
22C11	Sigma Aldrich (MO, USA)
Tau	Innogenetics (Gent, Belgium)
GSK-3β	BD Transduction Laboratories (Lexington, USA)
p- GSK-3β (S9)	Biosource (Nivelles, Belgium)
p- GSK-3β (Y216)	Biosource (Nivelles, Belgium)
BDNF	Abcam (UK)
ARC	Santa Cruz Biotechnolgy (Santa Cruz, USA)
B-Catenin	Millipore (MA)
Actin	Sigma Aldrich (MO, USA)
Leptin ObY20	Santa Cruz Biotechnolgy (Santa Cruz, USA)

3.4 CELL CULTURES AND TREATMENTS

3.4.1 Microglial human cells CHME3

Human microglial CHME3 cells were cultured at 37°C, 5% CO₂ in DMEM/high glucose supplemented with 2mM L-glutamine and 10% heat-inactivated FBS (Sigma-Aldrich, Sweden). Cells were grown to confluence.

3.4.2 Primary cultures of astrocytes

Cortical tissue from 18-day-old Sprague-Dawley rat embryos were homogenized in neurobasal medium supplemented with of 2% B27 (Invitrogen, Sweden). Cells from each embryo were seeded separately in dishes, pre-coated with 0.17 mg/ml poly-D-lysine MW 300,000 (Sigma-Aldrich, Sweden) in PBS. Cerebellum from 18-day-old Sprague-Dawley rat embryos were mechanically dissociated and seeded in Dulbecco's modified Eagles medium (DMEM/F12) containing 10% fetal bovine serum (FBS) for the preparation of rat primary astrocytes cultures, as previously described. Cells were plated in dishes with poly-D-lysine (Sigma-Aldrich, Sweden). Cultures were kept at 37°C in a moist atmosphere (95% air/5% CO₂). Culture media were replaced twice a week. Fourteen-day-old cultures were used for all experiments. At this time, astrocytes dominated as identified by immunocytochemical characterization. Cultures used for the experiments contained on average 300,000 \pm 10,000 cells per well. Most cells were flat, resembling inactivated astrocytes. Ethical consent for experiments with primary cultures was received from the regional ethical committee of Karolinska Institutet.

3.4.3 Neuroblastoma SH-SY5Y

Human SH-SY5Y neuroblastoma cells were cultured at 37°C, 5% CO₂, in minimum essential medium (MEM) with Glutamax containing 10% FBS (Sigma-Aldrich, Sweden). Cells were grown to confluence.

3.4.4 Cell treatments

Confluent cells, cultured in 6 well plates, were treated with:

- 10 nM A β (1–42)
- 10 nM human recombinant apoE isoforms (E3 or E4)
- apoE/A β complexes

A β (1–42) was dissolved in serum free MEM media (pH 7.4) at a concentration of 10 nM and aged for 24 hours by incubation at 37°C. Human recombinant apoE isoforms were dissolved in serum-free media to a concentration of 10 nM. The apoE/A β complexes were made by co-incubation at 37°C in neutral pH for 24 hours. A concentration of 3 nM apoE (E3 or E4 isoform) was added to 3nM A β (1-42), mixed and incubated for 24 h at 37°C²⁶³. Others have shown that similar preparations of A β (1–42) contain A β fibrils along with protofibrils and stable oligomers. A β (1–42) was purchased from Sigma Aldrich (Uppsala, Sweden) and apolipoprotein E3 and E4 isoforms were from Relia Tech GmbH (Germany). Subsequent treatments, cells were collected in PBS and after centrifugation at 1000 g for 3 minutes, lysed in a lysis buffer (50 mM Tris-HCl, 150 mM NaCl, 2mM EDTA, 2 mM EGTA, 1% Triton-X100) containing protease inhibitor and phosphatase inhibitor cocktails (Sigma-Aldrich, Sweden) at dilution 1:500 added freshly, and incubated 30 minutes on ice before centrifugation (13600g for 10 min) at 4°C. Immunoblotting was performed (as previously described) and membranes were incubated with the primary antibody for leptin (ObY20, Santa Cruz Biotechnology, USA) overnight at the concentration 1:1000

3.5 HUMAN SAMPLES

3.5.1 CSF samples

CSF was collected for diagnostic purposes by lumbar puncture in polypropylene tubes, mixed gently to avoid gradient effects and centrifuged at 2000 x g for 10 min. Aliquots were stored at -80°C until biochemical analysis. The patients were referred to the Memory Clinic at Karolinska University Hospital (Huddinge, Sweden). 99 patients were included in the study: 33 subjects with subjective cognitive impairment (controls, SCI), 26 stable MCI, 13 progressive MCI evolving to AD (PMCI) and 27 AD. The control group consisted of individuals with subjective cognitive impairment. MCI patients were: not demented; had subjective self and/or objective informant report of cognitive decline and impairment on objective cognitive tasks; had preserved basic activities of daily living and minimal impairment in complex instrumental functions. All the MCI patients used in this study developed AD within a 3 year period. The AD cases were diagnosed according to The Diagnostic and Statistical Manual of Mental Disorders-IV (DSM-IV) criteria. They were evaluated according to a standard comprehensive protocol including clinical examination, brain imaging (MRI and SPECT), electroencephalography (EEG), analyses of blood and CSF (including Total-Tau, Phospho-Tau and A β 1-42) and a detailed neuropsychological evaluation. The study was conducted under the guidelines of the Declaration of Helsinki and approved by the ethics committee of the Karolinska Institutet. Leptin levels in the CSF were measured by an enzyme immunoassay.

3.5.2. Postmortem samples and Brain tissue preparation

3.5.2.1 Samples for immunoistochemistry

Post-mortem brain material used for immunoistochemistry and immunofluorescence was obtained from the Brain Bank at Karolinska Institutet (Karolinska University Hospital, Huddinge, Sweden) with approval by the Human Ethics Committee of Karolinska University Hospital. Samples from frontal cortex and hippocampus from AD brains and aged-matched control were used. All brains had a post-mortem delay between 24 and 48 h. The AD cases had a mini mental state examination (MMSE) score between 2-15 and met the clinical diagnosis of probable AD (DSM-IV criteria) as well as definite AD according to the CERAD neuropathological criteria. Brain samples were fixed in buffered 4% formaldehyde and embedded in paraffin.

3.5.2.2 Samples for RT PCR

A total of 28 individuals from the Thomas Willis Oxford Brain Collection were included in the study, 16 patients with clinical diagnosis of dementia and 12 elderly normal controls matched for age, gender, post-mortem delay and brain pH. Those patients with dementia were an autopsied subset of subjects included in a prospective study of behavioural changes in clinically diagnosed as demented patients. Drug histories were recorded for all patients, and none of the patients with AD received cholinomimetics. At entry to the study assessment and diagnoses were made using Cambridge Mental Disorders of the Elderly Examination (CAMDEX), DMSIIR criteria, and NINCDSADRA criteria. Cognitive status was assessed using the MMSE. All tissues from control patients were examined by a pathologist and were confirmed to be free of gross neuropathology and clinical information indicated no gross neurological or psychiatric disorder. For all subjects, informed consent had been obtained from relatives before the removal of brain tissue at death and subsequent use of the material for research. The study had Local Ethics Committees' approval. Selection of subjects for the study was based on tissue availability, not gender, age, or disease severity. At autopsy, brains were removed and blocks corresponding to frontal (Brodmann area 10, BA10) cortex were stored at -80°C until processed. All patients were found to meet CERAD criteria for a diagnosis of AD and all brains were Braak stage 5 or 6 as assessed by a neuropathologist. To partially mitigate the possible effects of cause of death on neurochemical determinations, brain pH was measured with deionized water as an index of acidosis associated with terminal coma. Brain pH is used as an indication of tissue quality in post-mortem research, with $\text{pH}>6.1$ considered acceptable. All subsequent analysis was performed blind to clinical information.

3.5.3 Immunostochemistry and Immunofluorescence

Immunohistochemistry sections (7 μm thick) were mounted onto Superfrost plus-glass (Menzel Braunschweig, Germany). Sections were subjected to micro-wave antigen retrieval in sodium citrate buffer (10 mM, pH 6) at 700 W for 10 min. Unspecific binding was blocked by 5% normal goat serum (Sigma-Aldrich, Saint Louis, MO, USA) in PBS with 0.3% of Triton X-100 (PBS) before incubation over night with the primary antibody anti-leptin (Santa Cruz, USA) diluted in PBS with 1 % BSA overnight at 4°C . The sections were rinsed in PBS and incubated with the secondary antibody biotinylated goat IgG for 2 hours at room temperature. Rinsed in PBS between steps, the sections were incubated with avidin-biotin-

peroxidase complex (Vectastain Elite ABC reagent, Vector Laboratories, CA, USA), exposed to diaminobenzidine (DAB) and mounted with mounting medium (DAKO Cytomation, Denmark). All sections were treated simultaneously under the same conditions. For control staining the primary antibody was omitted. For immunofluorescence, after the incubation with primary antibody, sections were then incubated for 2 hours with secondary antibody (Goat antirabbit IgG-Cy3, 1:200 (red fluorescence); Goat antimouse IgG-FITC, 1:200 (green fluorescence), Jackson ImmunoResearch, PA) in PBS-Tx with 2% serum, after which counterstaining with DAPI was performed. Finally the sections were rinsed in PBS and mounted in fluorescence mounting medium (DAKO Cytomation, Glostrup, Denmark). The sections were thoroughly washed in PBS between different steps. All sections were treated simultaneously under the same conditions. For control staining the primary antibody was omitted. Inverted Meta-Zeiss 510 LSM confocal microscope (Carl Zeiss MicroImaging GmbH, Germany) was used for capturing images from the immunohistochemistry.

3.5.4 mRNA levels

Levels of mRNA coding for leptin are stable in post-mortem tissue. To measure leptin levels total mRNA was extracted from the frontal cortex, according to the instructions of NucleoSpin RNA II kit (MachereyNagel, Germany). DNAase treatment was performed with DNA free kit (Ambion, TX, USA), and purified total RNA used as a template to generate firststrand cDNA synthesis using MMLV reverse transcriptase (Invitrogen, CA, USA) as described by the manufacturer. Quantitative real time PCR was performed as described by the provider (Applied Biosystems, CA, USA) using an ABI PRISM 7000 HT Sequence Detection System. Taqman probes for leptin and GAPDH were also supplied by Applied Biosystems (CA, USA). Gene expression levels were normalized using GAPDH as internal control. Fold change between different groups of rats were calculated using the $2^{-\Delta\Delta C_t}$ method.

3.6. STATISTICAL ANALYSIS

Normal distribution of data was checked by Saphiro-Wilks prior to statistical analysis. Data in the figures are shown as mean \pm standard error mean (SEM). In the acquisition phase of Morris Water Maze latencies to find the platform were examined by Multiple-way ANOVA (MANOVA) for repeated measures with genotype, diet and day as sources of variation. To analyze Retention memory test (probe test), Passive avoidance (PA), Immunoblotting

experiments, data were analysed by One-way ANOVA followed either by LSD Fisher exact test (PA, WB) or Tukey's HSD test (learning phase, probe test).
A P value < 0.05 was considered statistically significant.

4. RESULTS

Figure 1

Figure 1 shows the effect of the interaction of apoE genotype and different diets on spatial learning and memory in Morris Water Maze (MWM) test. The escape latency to reach the hidden platform over the four days of training was used for the evaluation of spatial learning of mice. Swimming speeds were measured and no difference in speed or sensory motor functions were found among the six groups (data not shown), which enabled us to exclude the effect of motivational and sensory motor factors on animal learning and memory performance.

a) Figure 1a represents the performance of six-months-old apoE3 and apoE4 mice fed with normal diet (ND), high saturated fat and cholesterol (HC) and high carbohydrate diet (HS) on acquisition of the MWM test. Data are shown as escape latency to the platform. During the days of training (1-4) the time to reach the hidden platform decreased over the days (main effect of day on escape latency; $F=2.554$, $P<0.05$), indicating that all the groups at this age were able to learn the task. However, some differences between groups can be observed ($F=9.618$, $P<0.001$). As shown in figure 1a, across all days and diet groups, the escape latencies of the apoE3 fed with normal diet were shorter than the apoE4 fed with normal diet, suggesting an effect of the allelic variant by itself on cognitive performance ($P<0.01$). Furthermore, the apoE3 mice fed with different diets did not show differences in latency escape over the days, indicating that the spatial learning in apoE3 genotype was not affected by diet. In contrast to the apoE3 mice, apoE4 seemed to be more vulnerable to the effect of the diet. ApoE4 animals receiving high carbohydrate diet showed escape latency longer than apoE4 mice with fat diet and normal diet. This effect could be revealed by using the performance of the animals on a “trial-by-trial” basis approach, as explained in the following paragraph (fig.1b).

b) The figure 1b represents the performance of the apoE3 and apoE4 mice on acquisition of the Morris Water Maze test. Data are shown as escape latency for each of 6 trials per day for 4 consecutive days of training. In order to highlight the effect of the diet on the genotype apoE4, we analyzed the performance of the animals on a “trial-by-trial” basis. Notably, we

found that the apoE4 mice fed with HS diet had significantly longer escape latency at the first trial of the fourth day compared to the apoE4 ND and HC diet ($P < 0.001$).

Figure 2

Figure 2 shows the effect of the interaction between different diet and apoE3 apoE4 genotype on performance in the Morris Water Maze task during the probe test day.

In figure 2a memory retention performance are shown as escape latency to cross the former platform position. Results show that apoE4 HS present significant longer escape latency time to reach the platform position compared to apoE3 ND ($P < 0.05$).

In figure 2b memory retention performances are shown as time spent in the target quadrant where the platform was located during the acquisition. No statistical differences were observed between strain and diet.

Figure 3

The performances of six-months-old apoE3 and apoE4 mice fed with ND, HS and HC were evaluated on Passive Avoidance (PA) test, which is a memory test mainly dependent on the amygdala. The figure 3 shows the latency time to enter the dark compartment on the first day (training) and on the second day (probe) of PA test. At the first day all the groups showed similar step-trough latencies, indicating no differences in locomotor activity and anxiety-like behaviour among all groups. After 24 hours animals were tested. During the second day no statistical differences in the latency time to re-enter the dark compartment after the electric shock were found among all groups, although a trend toward significance ($P = 0.09$, Mann Whitney Test) is found when comparing E4 HS with E3 ND). These data suggest that, at this age, both the genotype groups retained contextual fear, showing no significant impairment in long-term memory amygdala-dependent.

Figure 4

a) Figure 4a represents the performance of thirteen-months-old apoE4 mice fed with normal diet (ND), high saturated fat and cholesterol (HC) and high carbohydrate diet (HS) on acquisition of the MWM test. Data are shown as mean escape latency to the platform. During the days of training (1-4) the time to reach the hidden platform decreased over the days in apoE4 mice fed on normal and high cholesterol diet ($F = 8.234$, $P < 0.01$) indicating that both the groups at this age were able to learn the task. As shown in figure 4a ApoE4 HS mice

present significant longer escape latency time to reach the platform on the third and fourth day of acquisition compared to apoE4 ND and apoE4 HC ($P < 0.01$), suggesting that apoE4 fed in high carbohydrate diet did not learn to locate the hidden platform during the days of training.

b) Figure 4b shows the effect of the interaction between different diet and thirteen months old apoE4 mice on performance in the Morris Water Maze task during the probe test day.

Memory retention performances are shown as time spent in the target quadrant where the platform was located during the acquisition. No statistical differences were observed among the groups.

Figure 5

The performances of thirteen-months-old apoE4 mice fed with ND, HS and HC were evaluated on Passive Avoidance (PA) test, which is a memory test mainly dependent on the amygdala. The figure 5 shows the latency time to enter the dark compartment on the first day (training) and on the second day (probe) of PA test. At the first day all the groups showed similar step-trough latencies, indicating no differences in locomotor activity and anxiety-like behaviour among all groups. After 24 hours animals were tested. During the second day apoE4 fed in high carbohydrate diet show significant shorter time to re-enter the dark compartment after the electric shock compared to apoE4 ND and HC ($P < 0.001$).

Figure 6

Immunoblot of frontal cortex homogenates from 6 months old apo3 and apoE4 mice fed on different diets were probed using antibodies against total GSK 3 β , phosphorylated GSK 3 β in Serine 9 and phosphorylated GSK 3 β in Tyrosine 216. The figure shows the quantification of the Optical Density (OD) data normalized as ratio to total GSK 3 β levels and expressed as percentage of values for control samples (E3 ND). Bars represent means \pm SEM of four animals per group.

No significant differences were found among the group when comparing the activity in frontal cortex (figure 6a), while apoE4 HS showed increase of p- GSK 3 β Tyr 216 levels compared with apoE3 ND ($P < 0.05$) (figure 6b).

Figure 7

Immunoblot of frontal cortex homogenates from 6 months old apo3 and apoE4 mice fed on different diets were probed using antibodies against N-terminus APP. Total staining of

proteins by Ponceaus was used as loading control. The figure shows the quantification of the Optical Density (OD) data expressed as percentage of values for control samples (E3 ND). Bars represent means \pm SEM of four animals per group. Significant increase of APP levels were found in apoE4 ND mice compared to apoE3 ND ($P < 0.001$) and in apoE4 HS and HC mice compared to apoE3 ND ($P < 0.01$)

Figure 8

Immunoblot of frontal cortex homogenates from 6 months old apo3 and apoE4 mice fed on different diets were probed using antibodies against total Tau protein. Total staining of proteins by Ponceaus was using as loading control. The figure shows the quantification of the Optical Density (OD) data expressed as percentage of values for control samples (E3 ND). Bars represent means \pm SEM of four animals per group. Data show a significant increase of total Tau levels in apoE4 ND mice compared to apoE3 ND ($P < 0.05$).

Figure 9

Immunoblot of hippocampus homogenates from 6 months old apo3 and apoE4 mice fed on different diets were probed using antibodies against Arc. Total staining of proteins by Ponceaus was used as loading control. The figure shows the quantification of the Optical Density (OD) data expressed as percentage of values for control samples (E3 ND). Bars represent means \pm SEM of four animals per group. Data show a significant decrease of Arc levels in apoE4 ND and HC mice compared to apoE3 ND ($P < 0.01$).

Figure 10

Immunoblot of hippocampus homogenates from 6 months old apo3 and apoE4 mice fed on different diets were probed using antibodies against BDNF. Total staining of proteins by Ponceaus was used as loading control. The figure shows the quantification of the Optical Density (OD) data expressed as percentage of values for control samples (E3 ND). Bars represent means \pm SEM of eight animals per group.

c) Figure shows a significant decrease of BDNF levels in apoE4 HS mice compared to apoE3 HS ($P < 0.05$).

Figure 11

Immunoblot of hippocampus homogenates from 6 months old apo3 and apoE4 mice fed on different diets were probed using antibodies against β -catenin. Total staining of proteins by Ponceaus was used as loading control. The figure shows the quantification of the Optical Density (OD) data expressed as percentage of values for control samples (E3 ND). Bars represent means \pm SEM of eight animals per group.

b) Figure shows a significant decrease of β -catenin levels in apoE4 HC mice compared to apoE3 HC ($P < 0.05$).

c) Figure shows a significant decrease of β -catenin levels in apoE4 HS mice compared to apoE3 HS ($P < 0.01$).

Figure 12

Immunoblot of hippocampus and frontal cortex homogenates from 13 months old apo4 and wild type mice were probed using antibodies against leptin. Total staining of proteins by Ponceaus was used as loading control. The figure shows the quantification of the Optical Density (OD) data normalized as ratio to actin levels and expressed as percentage of values for control groups (WT mice). Bars represent means \pm SEM of four animals per group. The figure shows a significant increase of leptin levels in apoE4 mice compared to WT mice in both frontal cortex and hippocampus ($P < 0.05$).

Figure 13

a) Figure 13a shows fasting CSF-leptin ($\mu\text{l/mL}$) with standard errors measured for subjective cognitive impairment (SCI), stable Mild Cognitive Impairment (SMCI), Mild Cognitive Impairment with AD progression (PMCI) and AD patients. Subjects with mild cognitive impairment, whom later progressed to AD (PMCI) and AD apoE4 carriers showed significant higher levels of CSF leptin compared to apoE3 carriers. ($P < 0.01$).

b) Figure 13b shows fasting CSF-leptin ($\mu\text{l/mL}$) with standard errors measured for male and female SCI, SMCI, PMCI and AD groups. SMCI and PMCI women showed a trend of increase of CSF-leptin when compared to men of the same group by nearly reaching significance.

Figure 14

Leptin gene expression was evaluated by RT-PCR. The figure represents mRNA expression levels of leptin normalized using GAPDH as an internal control in brains of controls and AD patients, apoE3 and apoE4 carriers, male and female. Significant increase of mRNA leptin expression were found in AD patients compared to controls ($P < 0.05$).

Figures 15 and 16

Figures 15 and figure 16 show DAB immunohistochemistry in cortical and hippocampal sections from two AD brains and two control brains. In AD brains, in both frontal cortex and hippocampus, leptin is decreased in neurons and is increased in glial-like profiles compared to control brains.

Figure 17

Figure 17 shows double immunofluorescence staining for leptin and GFAP of frontal cortex from one AD brain and one control brain. In AD brain leptin staining (red fluorescence) is increased compared to control brain. Furthermore, in AD brain leptin staining overlaps with GFAP staining for astrocytes, confirming the results obtained from the DAB staining.

Figure 18

Immunoblot of CHME3 microglial human cells lysate was probed using antibody against leptin. Effects on leptin levels after 6 hours (figure 18a) and 24 hours (figure 18b) of different treatments (10 nM A β 1–42, 10 nM human recombinant apoE3 and apoE4 isoforms and apoE3, apoE4/A β combination) were evaluated. The figures show the quantification of the Optical Density (OD) data normalized as ratio to actin levels and expressed as percentage of values for control groups (untreated cells). Bars represent means \pm SEM of three experiments performed in triplicate. Increase of leptin levels was found in cells treated for 24 hours with apoE4/A β combination compared to untreated cells ($P < 0.05$).

Figure 19

Immunoblot of astrocyte cells from primary rat were probed using antibody against leptin. Effects on leptin levels after 24 hours of different treatments (10 nM A β 1–42, 10 nM human recombinant apoE3 and apoE4 isoforms and apoE3, apoE4/A β combination) were evaluated. The figure shows the quantification of the Optical Density (OD) data normalized as ratio to

actin levels and expressed as percentage of values for control groups (untreated cells). Bars represent means \pm SEM. Increase of leptin levels was found in cells treated for 24 hours with apoE4/A β combination compared to untreated cells ($P < 0.05$).

5. DISCUSSION

Sporadic Alzheimer's Disease is probably caused by several both genetic and environmental risk factors.¹⁰⁵ The major genetic risk factor is the $\epsilon 4$ variant of apolipoprotein E gene (*ApoE*, on chromosome 19 called apoE4.¹⁰⁸ Several risk factors for developing AD have been identified including lifestyle, such as dietary habits. AD is a multifactorial disease and the mechanisms behind the AD pathogenesis and the onset of cognitive decline in the AD brain are presently unknown.

In this study we wanted to characterize the effects of the interaction between environmental risk factors and apoE genotype on neurodegeneration processes, with particular focus on behavioural studies. Towards this aim, we investigated 6 months-old apoE4 and apoE3 mice fed on different diets (high intake of cholesterol and high intake of carbohydrates). These mice were evaluated for learning and memory deficits in spatial reference (Morris Water Maze (MWM)) and contextual learning (Passive Avoidance) tasks, which involve the hippocampus and the amygdala, respectively.²⁶⁴

Since neurodegenerative processes of AD are accompanied by hippocampal dependent learning and memory deficit, mice were tested in the MWM. Results from the MWM tests show that all the groups of mice at 6 months of age were able to learn the task. However, during the acquisition phase, the escape latencies to find the platform of the apoE3 mice fed on normal diet were shorter than for the apoE4 mice. Thus, the better performances of apoE3 mice among all the days of training suggest an effect of the allelic variant by itself on cognitive performance. This data agree with studies that support the hypothesis that apoE4 compared to apoE3 has a deleterious effect on spatial cognitive processes also in young mice.²⁶⁵ Furthermore, the apoE3 mice fed with different diets did not show differences in latency escape over the days, indicating that the spatial learning in apoE3 genotype was not affected by diet. In contrast to the apoE3 mice, apoE4 seemed to be more vulnerable to the effect of the diet. When representing the learning phase divided by each trial for every day of training, we found that the apoE4 mice fed with HS diet had significantly longer escape latency at the first trial of the fourth day compared to the apoE4 ND and HC diet. These data suggest the interaction between apoE4 genotype and carbohydrate diet affects long term spatial reference memory in 6 months old mice. Based on these data, it seems that apoE4 mice fed with high carbohydrate diet have difficulty retaining the information from day to day but are still able to learn the task at this age. Therefore, the poorer performance of apoE4 HS in the MWM task seems to be caused by an early cognitive impairment manifested as retention,

not learning deficits. Similar results have been shown during the probe test. After 24 hours from the last session of training: the escape latency of apoE4 mice HS is significantly longer than apoE3 mice fed with normal diet. These data underline a deficit of apoE4 HS in spatial memory compare to apoE3. Similar results were previously shown by result, reporting inconsistent probe trial retention performances of apoE4, have been reported by Grootendost et al., while Raber et al. showed no retention deficits in 6 months male apoE4.²⁶⁶

Since AD pathology is also predominant in amygdala, the performances of the mice were evaluated on Passive Avoidance (PA) test, which is a memory test mainly dependent on the amygdala. On the second day (probe day) all the groups showed similar latency time to re-enter the dark compartment, where the electric shock was delivered on the first day (training day). These data suggest that at 6 months of age, both apoE3 and apoE4 retained contextual fear, showing that long-term memory amygdala-dependent is not affected by different isoforms of apoE. As in the Morris Water Maze task, the diet did not affect cognitive function in apoE3 mice, while the interaction between high carbohydrate diet and apoE4 genotype seems to affect memory retention since a trend toward significance was found when comparing apoE4 HS with apoE3 ND.

From these behavioural studies we found that the initial cognitive impairments manifested as a retention deficit in apoE4 mice fed on high carbohydrate diet. Spatial memory retention processes were already compromised at this age. Thus, the genetic risk factor apoE4 genotype associated with a high carbohydrate diet seems to affect cognitive functions in young mice, corroborating the theory that the combination of genetic and environmental risk factors greatly increases the risk of developing AD and leads to an earlier onset of cognitive deficits. Interestingly, no differences were found with the diet with high percentage of cholesterol, probably because of the high amount of unsaturated fats (known as protective risk factors) contained in the soybean oil.

The cellular and molecular bases of the cognitive decline in AD are largely unknown. The altered synaptic plasticity may also change the dynamic interaction among cells in hippocampal networks, causing deficits in the storage and retrieval of information about the spatial organization of the environment.²⁶⁷ Thus, we performed molecular studies in hippocampus in order to determine the molecular changes for the onset of early cognitive impairment shown in the behavioural studies. Interestingly, we found a significant decrease of BDNF in apoE4 mice fed on high carbohydrate diet. BDNF is critical to organization of neuronal networks, synaptic plasticity, memory formation and long term potentiation,

especially in the hippocampus, in a variety of animal models and in humans. BDNF protein is decreased in hippocampus and neocortex of AD brains.^{63,74,75} BDNF and its precursor PRO-BDNF deficiencies were found to be present not only in cases of severe AD, but even in earlier mild stages of the disease such as mild cognitive impairment.⁸² Therefore, BDNF deficiency may be an early hallmark of AD and an important factor in the progression of the disease. Our results may suggest that BDNF decrease found in apoE4 HS mice could be involved in the earliest impairment in long-term reference memory observed in MWM task. Moreover, a link combining BDNF and AD pathogenesis is BDNF as regulator of GSK-3 β . BDNF increases the phosphorylation of S9-GSK-3 β , which turns the kinase activity off.⁸⁵ Interestingly when comparing level of S9-GSK-3 β activity no differences are found among the groups, while a slight significant increase of Tyr-216-GSK-3 β was found in apoE4 mice fed with high carbohydrate diet compared to apoE3 ND. Preliminary studies showed significant increase of total Tau level, that expresses both the physiological and the pathological forms of Tau, among all the apoE4 mice. Increase of the activity of Tyr 216-GSK-3 β and of total Tau could suggest increase of phosphorylation at pathological sites in hippocampus of apoE4 HS mice. To confirm this hypothesis these studies need to be completed. Moreover, from our results it could be observed that the presence of the E4 isoform leads to increase of levels of Amyloid Precursor Protein. It will be important to complete this study in order to show if this overexpression of APP corresponds to over production of soluble APP (sAPP β), of the membrane bound C-terminal fragment (CTF, C99), APP intracellular domain (AICD) and finally A β in hippocampus of apoE4 mice. Arc expression is severely disrupted in Alzheimer's disease mouse models. In some cases extremely high levels of Arc have been observed and in others there is a lack of normal Arc induction after experience. Taken together, these findings suggest that overexpression or dysregulation of Arc protein levels is potentially a causative factor in synaptic dysfunction. Decrease of Arc where found among all the apoE4 mice compared to apoE3 mice, confirming that the presence of apoE4 expression at this age may induce Arc-dependent alterations in hippocampal synaptic plasticity, independently from the diet. ApoE4 mice performances in behavioural studies were poorer compared to apoE3 mice. From these studies we hypothesized that there is an interaction between E4 isoform and diet. That the E4 carriers are more susceptible to an high carbohydrate diet. It could be clear that also insulin resistance is involved, which affects E4 carriers in term of cognitive functions. These mice fed on high carbohydrate diet may have hyperinsulinemia. It is known that

hyperinsulinemia may inhibit brain insulin production which in turn results in impaired amyloid clearance and a higher risk of AD.¹⁵⁸ Levels of insulin receptors, glucose-transport proteins and other insulin pathway components in the brain are reduced in some studies of Alzheimer's disease (central resistance).²²⁵ Insulin and brain-derived insulin-like-growth factor (IGF) are extracellular ligands that regulate metabolic activity and activate many of the same intracellular signaling cascades as neurotrophins.⁷⁸ Thus, endogenous insulin signaling is important for maintaining relatively low phosphorylation levels of Tau. Downregulation of insulin signaling may be a factor leading to Tau hyperphosphorylation levels and cytoplasmic aggregation in apoE4 mice HS. These processes could lead to earliest cognitive impairments observed in behavioural studies. Based on our experimental results, the role of possible change in insulin plasma and brain levels of these mice and correlated alteration in insulin signaling pathway will be the next goal.

To determine whether the early memory deficits observed in 6 months old apoE4 HS mice get worse with age we tested 13 months old apoE4 mice fed on different diets for the same behavioural tasks. As we expected, the high carbohydrate diet significantly affects the performances of apoE4 mice in the MWM and PA test. In this case, the results from behavioural studies showed that cognitive deficits manifest both in learning and retention memory in mice fed with high carbohydrate diet. In the MWM test, ApoE4 HS showed significant longer escape latencies to find the platform on the third and fourth day of training, compared to apoE4 fed on normal and fat diet. This indicates that the animals did not learn the task. However, no differences were found during the probe test when comparing the time spent in the target where the platform was located, suggesting that the information is not retained among all the groups. Probably, as reported by Grootendost et al. apoE4 expression in mice at this age results in cognitive deficits in long term memory hippocampal dependent. Furthermore, 13 months old apoE4 mice were tested for passive avoidance. Notably, apoE4 mice fed on high carbohydrate diet showed a significantly shorter latency time to re-enter in the dark compartment compared with groups receiving normal and fat diet. This indicates that a diet, rich in carbohydrate, strongly affect apoE4 genotype and retention memory amygdala-dependent. Based on these results, we clearly observed that interactions between high carbohydrate diet and the presence of genotype apoE4 affect learning and retention memory. Studies to evaluate molecular differences and changes related to age in this animal model are ongoing.

The second aim of this thesis was to study possible involvement of leptin in AD. Leptin receptors are abundantly expressed in several brain regions, including cortex, thalamus, cerebellum, midbrain and hippocampus (primarily in the dentate gyrus and CA1, areas heavily affected in AD). Moreover, recent studies have demonstrated the potential beneficial effects of leptin as an AD therapeutic.²⁴⁷ Leptin is capable of modulating both the production of A β and phosphorylation of tau, two main pathological hallmarks of AD. Further, administration of leptin rapidly normalizes synaptic function.²⁵⁰ Recently, it was shown that direct injection of leptin into the hippocampus of rodents can improve memory processing and modulate long term potentiation and synaptic plasticity. Moreover, Leptin-treated transgenic mice, an animal model of AD, showed significantly reduced levels of A β in brain and serum and a reduction of phosphorylated tau in Ser³⁹⁶. Moreover, biochemical and pathological changes were correlated with cognitive improvements in memory tests.²⁵³ Improved memory following leptin administration was also found in SAMP-8 mice, an accelerated senescence rodent model that develops amyloid plaques.

Thus, given to the importance of the involvement of leptin in AD, we wanted to investigate if apoE genotype affects leptin levels in old apoE4 TR mice. These apoE4 mice showed retention memory deficits in the MWM task compared to WT, confirming that apoE4 affects age related cognitive decline. No cognitive deficits were found in WT mice at the same age. Immunoblotting against leptin antibody in hippocampus and frontal cortex of wild type and apoE4 13-months old mice showed an unexpected increase of leptin levels in both cerebral areas of apoE4 mice compared to WT mice. Given to the demonstrated neuroprotective functions of leptin in SNC we expected levels of leptin to be lower in apoE4 mice compared to WT mice.

In parallel to these studies, we performed analysis of CSF and brain of human AD patients, both E3 and E4 carriers. We found that CSF level of leptin are significant increased in apoE4 carriers compared to E3 carriers with confirmed Alzheimer's disease. No differences were found between E3 and E4 patients presenting subjective cognitive impairment (SCI) and stable mild cognitive impairment (SMCI). Subjects with mild cognitive impairment, whom later progressed to AD (PMCI), and with AD apoE4 carriers showed significant higher levels of CSF leptin compared to apoE3 carriers. These findings suggest that the increase of leptin is related to the stage of the cognitive decline of the patients analyzed and that presence of apoE4 isoform affects leptin levels in CSF. Moreover, CSF-leptin levels were measured for male and female SCI, SMCI, PMCI and AD groups. SMCI and PMCI women showed a trend

of increased levels of CSF-leptin when compared to men of the same group (by nearly reaching significance), suggesting a gender dependent effect of leptin. To confirm that increased levels of leptin are likely to be involved in AD we performed further investigations. We found that mRNA expression of leptin in brain of AD patients is significantly increased compared to healthy controls. Moreover, apoE4 carriers showed significant increase of mRNA expression of leptin compared to apoE3 carriers, confirming our hypothesis that apoE genotype affects leptin expression. This result, showing an increase of leptin in CNS, seems to be in agreement with increase of leptin levels found in 13 months old apoE4 TR mice.

In order to understand how leptin is expressed in AD brains, further studies were performed on frontal cortex and hippocampus of AD patients. Interestingly, immunostaining in hippocampus and frontal cortex showed that leptin is overexpressed in AD brains and is upregulated in glial cells of AD patients compared to healthy control subjects. Then the results were confirmed, by an immunofluorescence technique. We found that leptin in AD brains co-localizes with astrocytes cells, suggesting that leptin in frontal cortex and hippocampus of AD patients is upregulated in reactive astrocytes compared to control patients.

Finally, the levels of leptin were evaluated in vitro, in microglial human cells and primary culture of astrocytes. The effect on leptin levels after treatment with apoE4 and apoE3 genotype as well as amyloid β was studied. According to our findings, production of leptin by astrocytes and microglia cells significantly increases after apoE4 and amyloid β treatment.

In conclusion our findings suggest that apoE4 TR mice showed an increase of leptin in the brain. Leptin is increased in the CSF of AD patients and it can be expressed in the brain in some particular situation. ApoE4 carriers with AD have higher levels of leptin than apoE3 carriers. Moreover, leptin seems to be expressed by reactive glial cells in AD brains. In vitro, ApoE4 together with A β increases leptin production by microglia and astrocytes. Taken together, all these findings suggest that leptin replacement might not be a good strategy for AD therapy.

Our results show that high leptin levels were found in AD brains, thus, as high leptin levels do not promote satiety in obese individuals, it might be possible that they do not promote neuroprotection in AD patients. We hypothesized that AD brain could suffer from leptin resistance. However, neuroprotection is not achieved by hyperleptinemia in obese individuals. The underlying molecular mechanisms in AD brains may be the same as those that cause neuronal resistance to leptin satiety effects. Further studies will be critical to determine,

whether or not the central leptin resistance in SNC could affect its potential neuroprotective effects, focused on leptin signaling pathway. Additional studies are needed to elucidate the molecular mechanism by which leptin might be protective for developing AD.²⁵⁶

There are still several questions that remain unanswered, such as the mechanisms by which high circulating levels of leptin protect from developing AD and the stage of the disease process at which leptin acts. All these findings point out the importance of leptin in Alzheimer's disease and reinforce the importance of this hormone as a link between adipose tissue and brain. Metabolic pathways have been shown to be very important in AD, thus need further investigation.

7. FIGURES

Figure 1:

a)

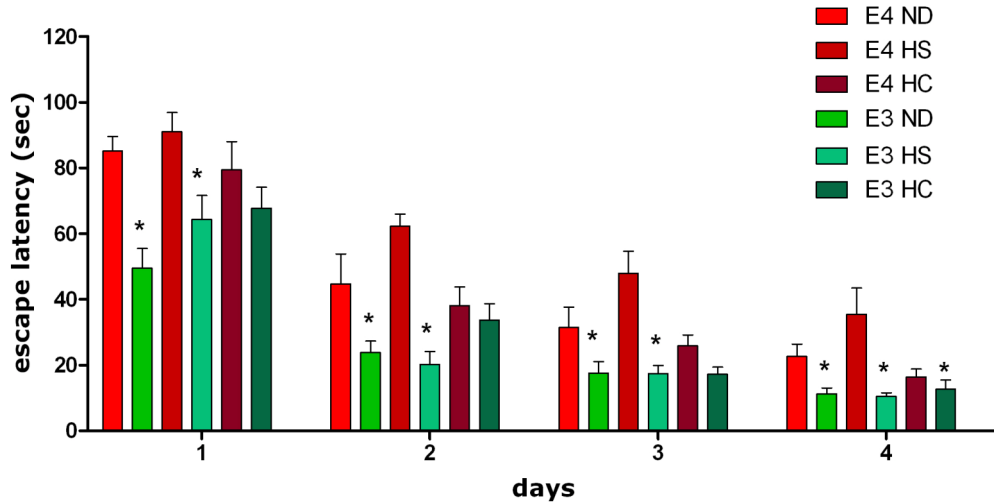

b)

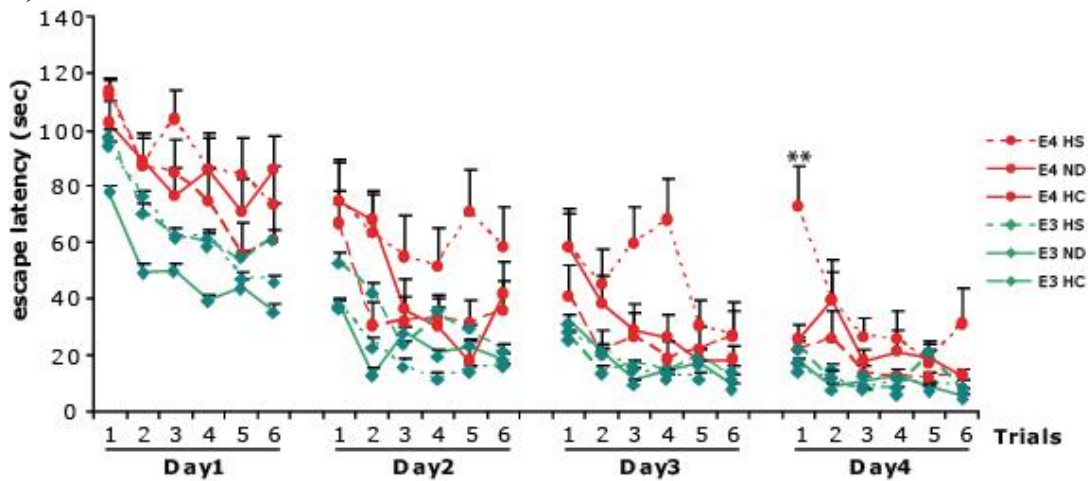

Figure 1: Effect of the interaction between diet and apoE3 apoE4 genotype on the performance in the Morris Water Maze task.

a) Acquisition is shown as mean escape latencies to find the platform for each day of training.

(* $P < 0.05$ vs apoE4 HS)

b) Acquisition is shown as escape latency for each of the 6 trials per day. (** $P < 0.01$ vs apoE4 ND)

Figure 2:

a)

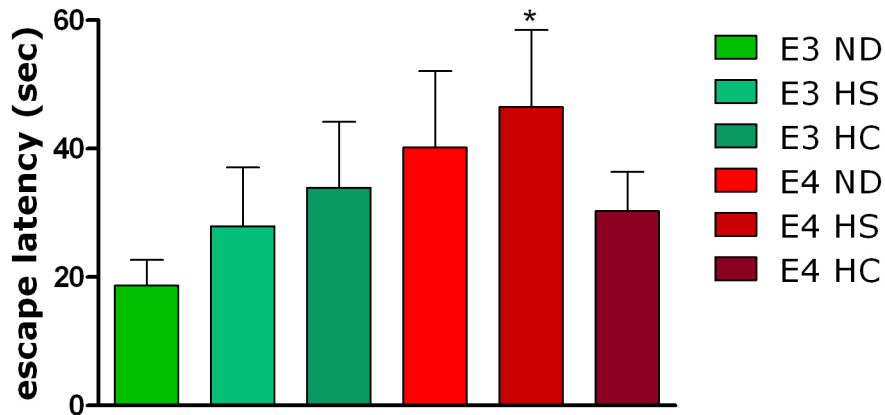

b)

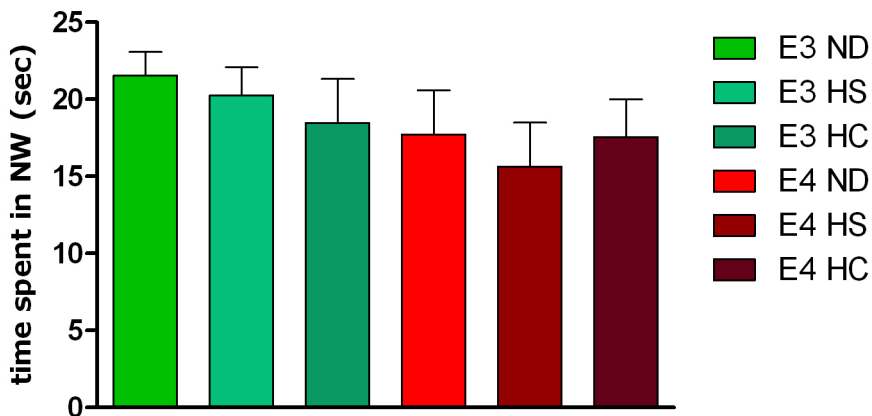

Figure 2b: Effect of the interaction between different diet and apoE3 apoE4 genotype on performance in the Morris Water Maze task during the probe test day.

a) Memory retention is shown as escape latency to cross the former platform position. (* P<0.05 vs apoE3 ND)

b) Memory retention is shown as time spent in the target quadrant where the platform was located during the acquisition.

Figure 3:

a)

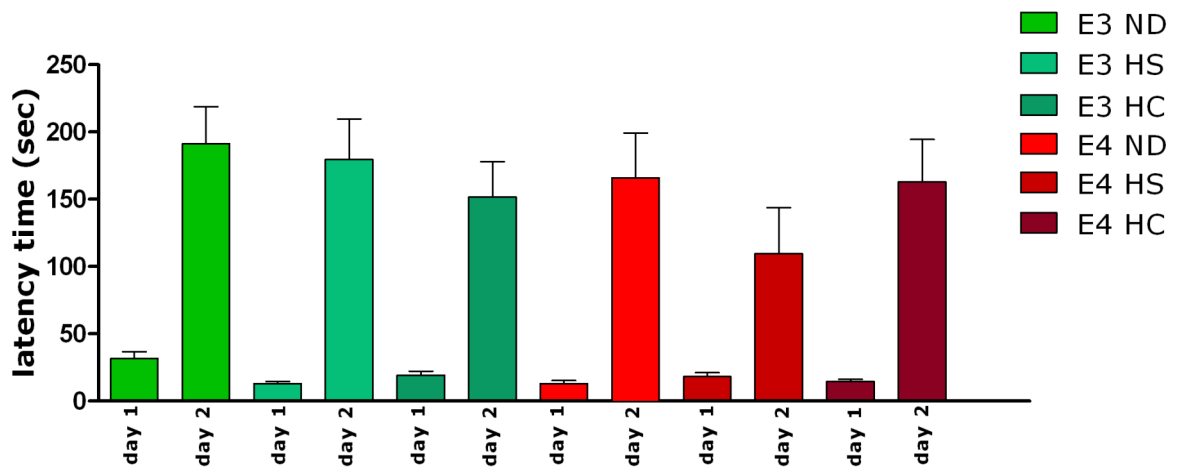

b)

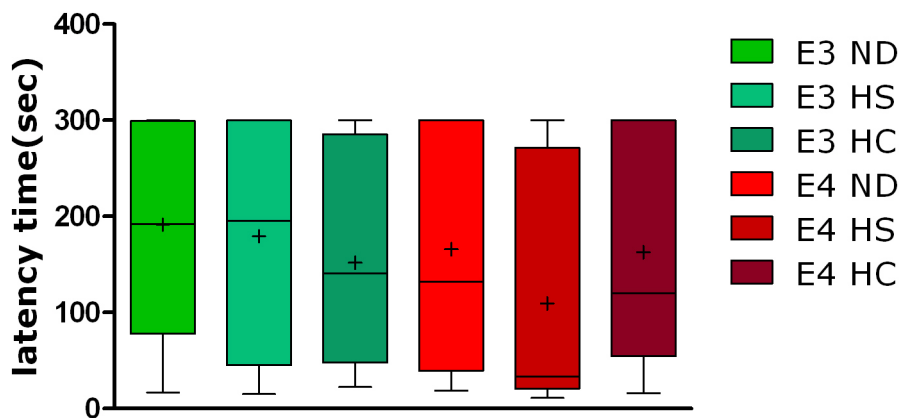

Figure 3: Effect of the interaction between different diet and apoE3 apoE4 genotype on performance in the Passive Avoidance test.

a) Data are shown as latency time to enter the dark compartment on the first and second day of the test.

b) Retention memory is shown as latency time to enter the dark compartment on the second day of the test. Data are shown as median, error bars show min and max, + represent the mean value.

Figure 4:

a)

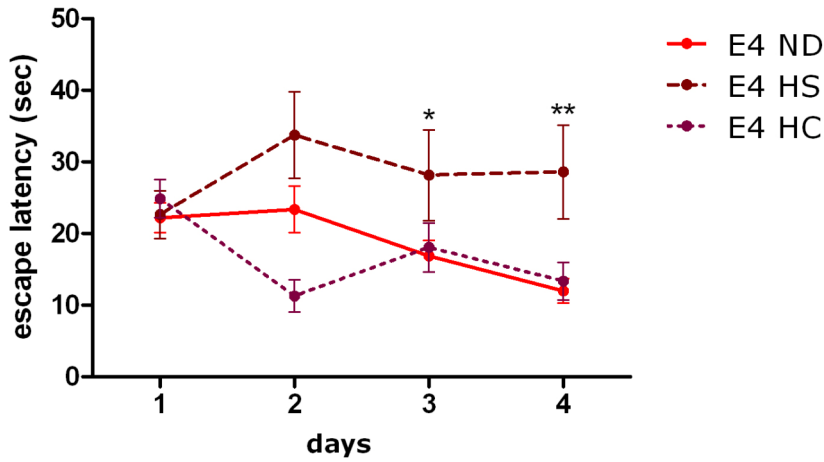

Figure 4a: Effect of different diet on 13 months-old apoE4 mice on the acquisition phase of the Morris Water Maze task. Performance is shown as mean escape latency for each day of training. (** P<0.01 vs apoE4 ND, * P<0.05 vs apoE4 ND)

b)

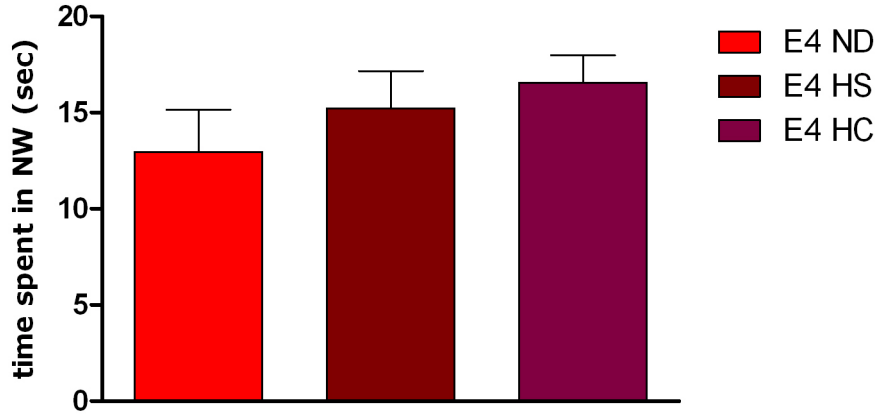

Figure 4b: Effect of different diet on 13 months-old apoE4 mice on the probe test of the Morris Water Maze task. Performance is shown as time spent in the target where the platform was located during the acquisition phase.

Figure 5:

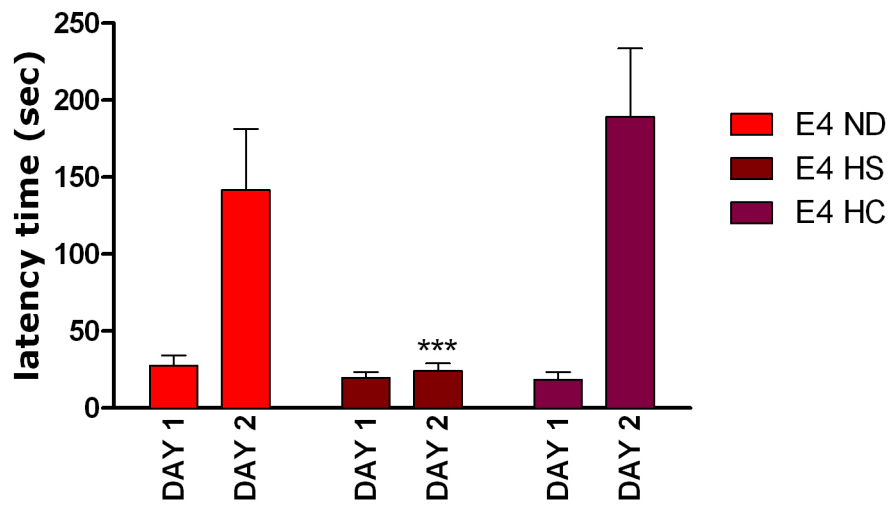

Figure 5: Effect of different diet on 13 months-old apoE4 mice on the Passive Avoidance task. Data are shown as latency time to enter the dark compartment on the first and second day of the test. (***) $P < 0.001$ vs apoE4 ND)

Figure 6:

a)

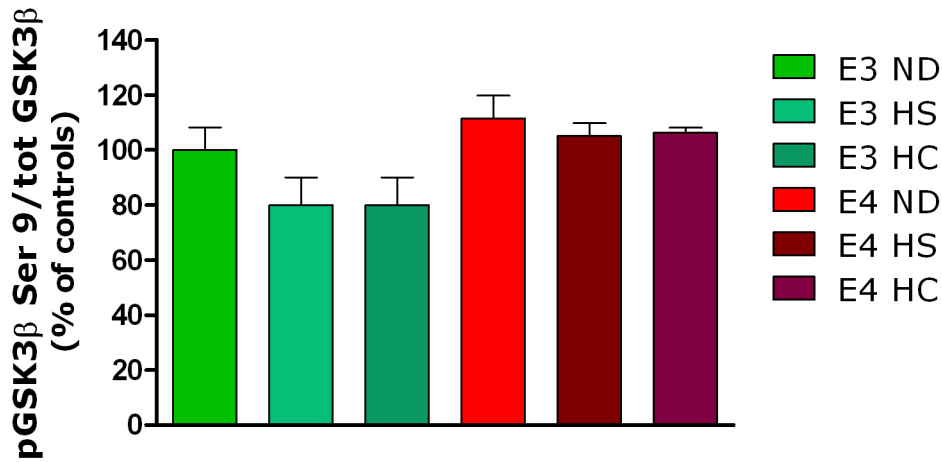

Figure 6a: Immunoblotting. Effects of the interaction between different diets and apoE3 apoE4 genotype on p-GSK 3 β Ser 9 levels in frontal cortex. Data are expressed as percentage of values for control group (E3 ND) and represent the mean + SEM.

b)

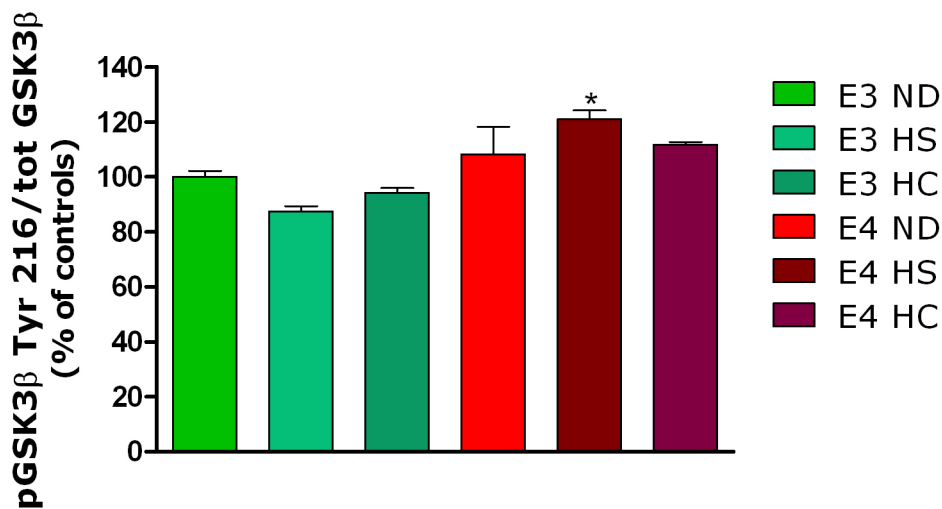

Figure 6b: Immunoblotting. Effects of the interaction between different diets and apoE3 apoE4 genotype on p-GSK 3 β Tyr 216 levels in frontal cortex. Data are expressed as percentage of values for control group (E3 ND) and represent the mean + SEM. (* P < 0.05 vs apoE3 ND)

Figure 7:

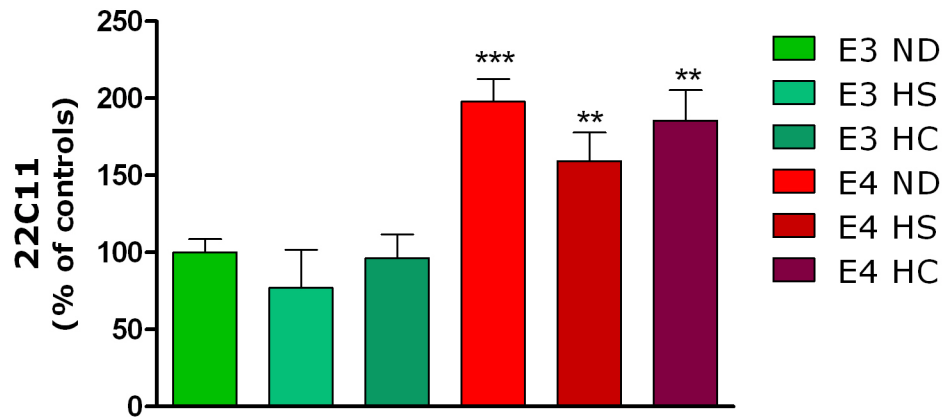

Figure 7: Immunoblotting. Effects of the interaction between different diets and apoE3 apoE4 genotype on p-22C11 levels in frontal cortex. Data are expressed as percentage of values for control group (E3 ND) and represent the mean + SEM. (***) $p < 0.001$ vs apoE3 ND; ** $P < 0.01$ vs apoE3 ND)

Figure 8:

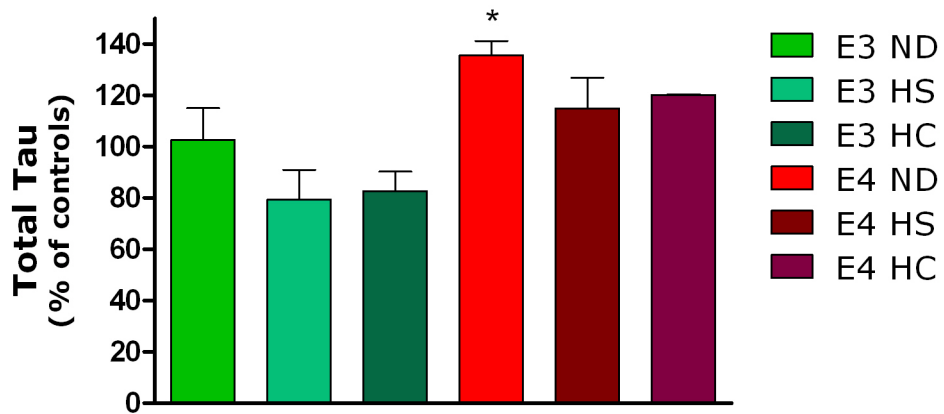

Figure 8: Immunoblotting. Effects of the interaction between different diets and apoE3 apoE4 genotype on total Tau levels in frontal cortex. Data are expressed as percentage of values for control group (E3 ND) and represent the mean + SEM.

(* P<0.05 vs apoE3 ND)

Figure 9:

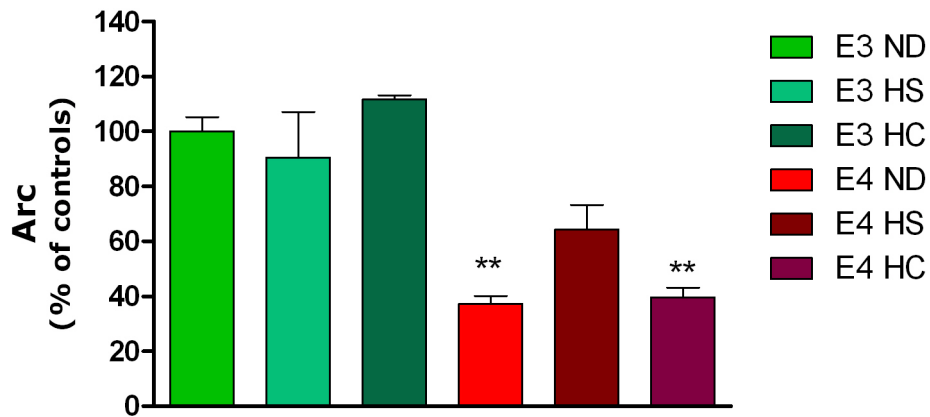

Figure 9: Immunoblotting. Effects of the interaction between different diets and apoE3 apoE4 genotype on Arc levels in hippocampus. Data are expressed as percentage of values for control group (E3 ND) and represent the mean + SEM.

(** P<0.01 vs apoE3 ND)

Figure 10:

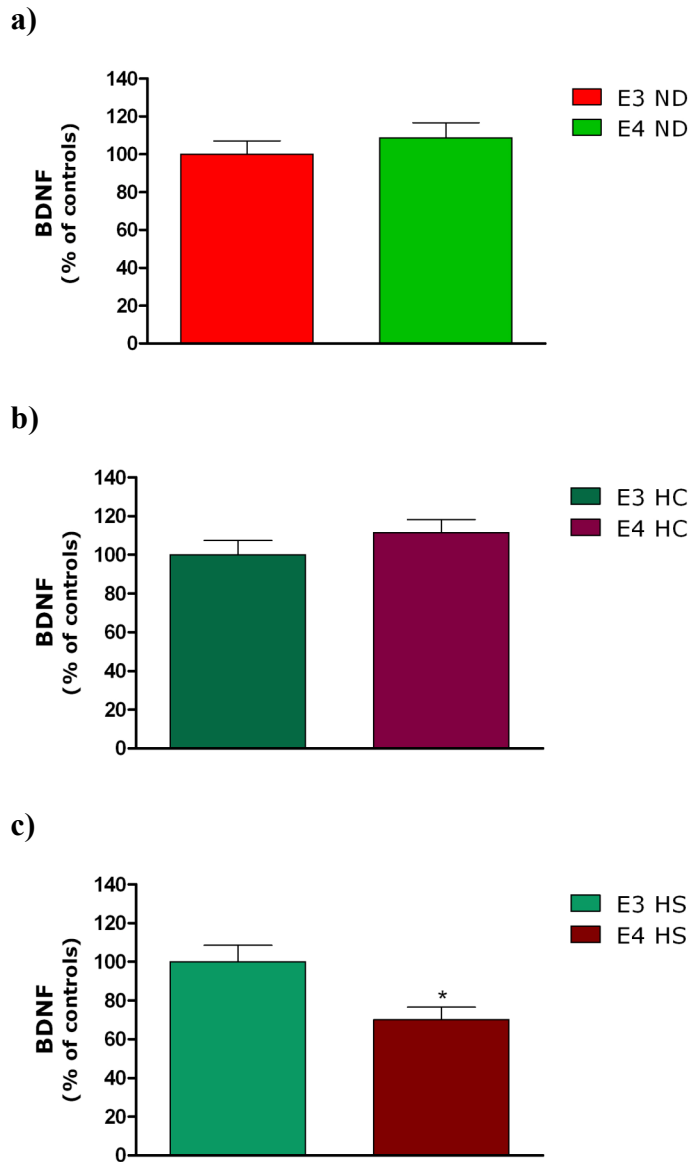

Figure 10: Immunoblotting. Effects of the interaction between different diets and apoE3 apoE4 genotype on BDNF levels in hippocampus. Data are expressed as percentage of values for each control group (E3) and represent the mean + SEM.

c) * $P < 0.05$ vs apoE3 HS

Figure 11:

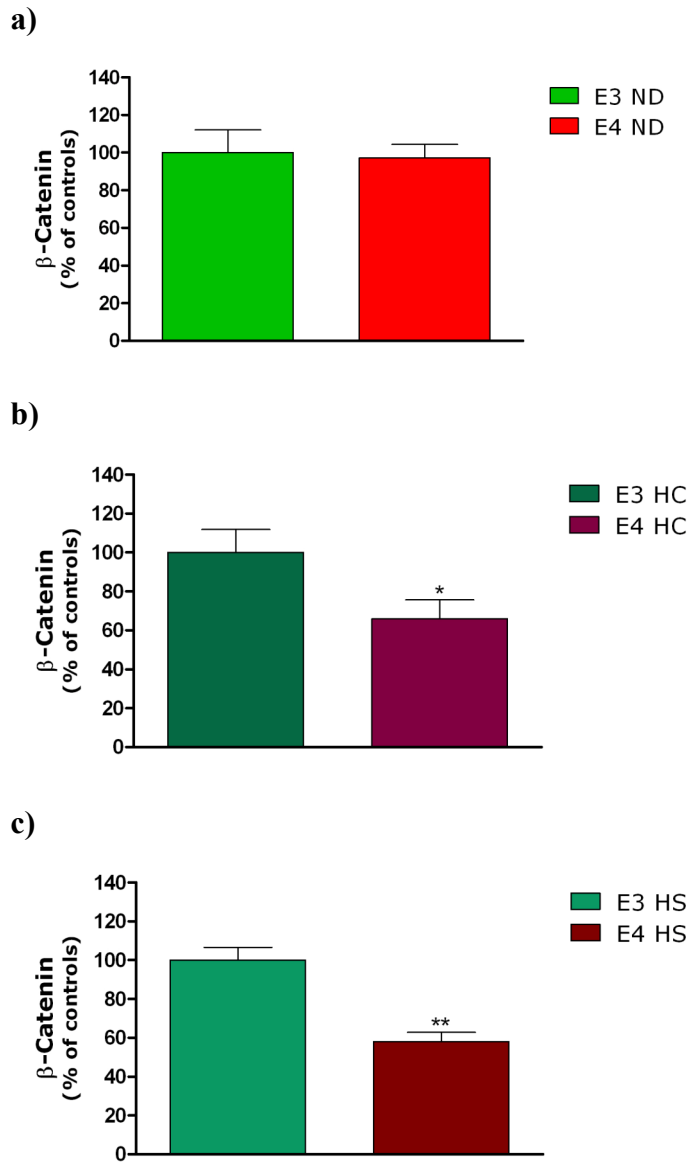

Figure 11: Immunoblotting. Effects of the interaction between different diets and apoE3 apoE4 genotype on β -Catenin levels in hippocampus. Data are expressed as percentage of values for each control group (E3) and represent the mean + SEM.

b) * P <0.05 vs apoE3 HC

c) ** P <0.05 vs apoE3 HS

Figure 12:

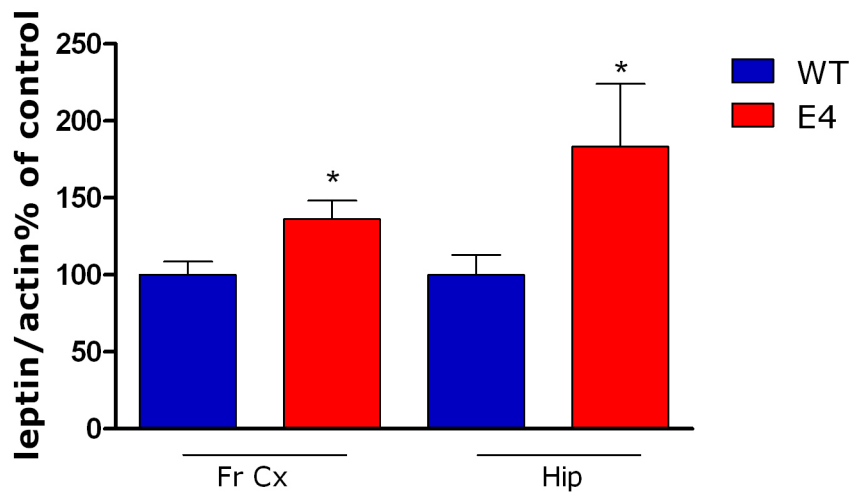

Figure 12: Immunoblot of hippocampus and frontal cortex homogenates from 13 months old apo4 and wild type mice were probed using antibodies against leptin. Data are expressed as percentage of values for each control group (WT) and represent the mean + SEM.

* P < 0.05 vs WT

Figure 13:

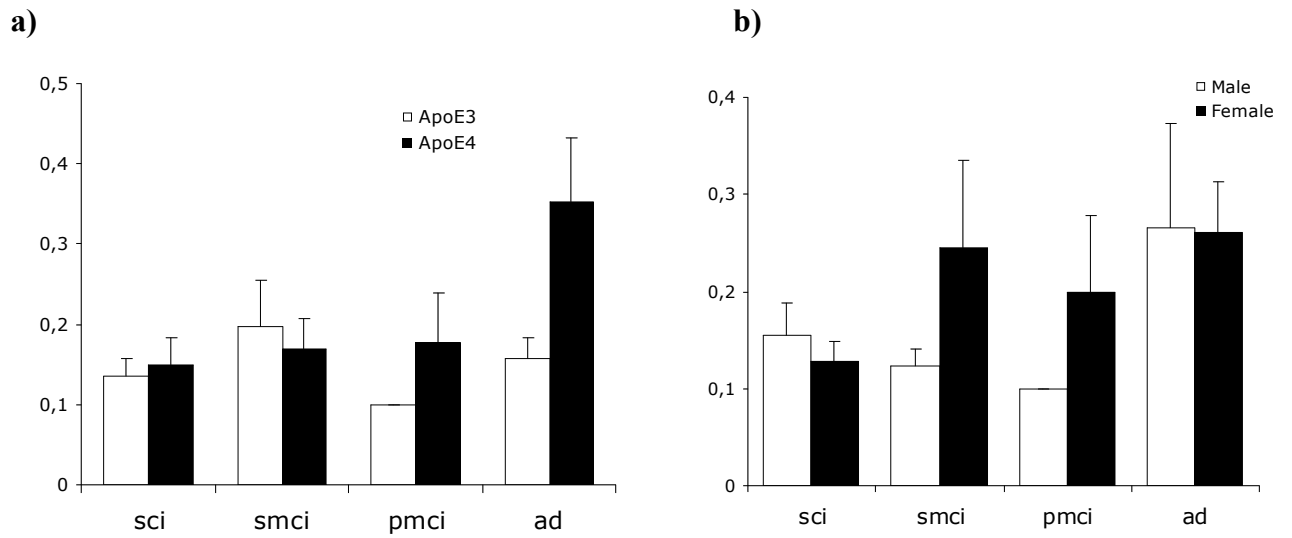

Figure 13:

a) Fasting CSF-leptin ($\mu\text{l/mL}$) with standard errors for the overall subjective cognitive impairment (SCI), stable MCI (SMCI), MCI with AD progression (PMCI) and AD.

b) Fasting CSF-leptin ($\mu\text{l/mL}$) with standard errors for male (white columns) and female (black columns) SCI, SMCI, PMCI and AD groups.

Figure 14:

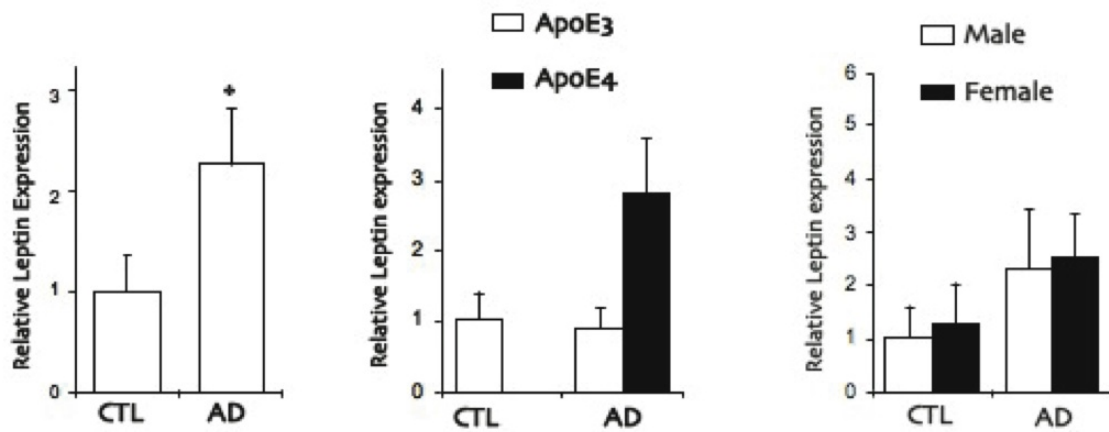

Figure 14: Expression of mRNA leptin level by RT-PCR in control and AD patients, apoE3 and apoE4 carriers, male and female. Gene expression levels were normalized using GAPDH as internal control. (+ $P < 0.05$ vs ctl)

Figure 15:

a)

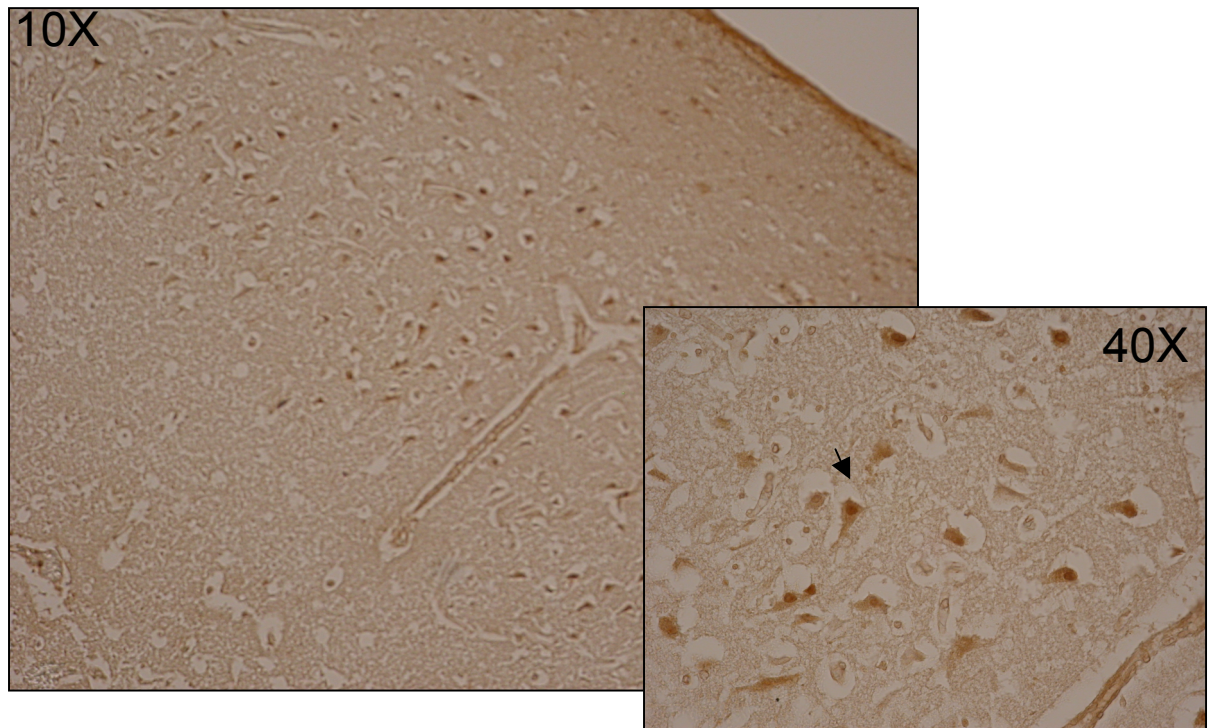

Figure 15a: DAB staining of leptin in hippocampus of an healthy control.

b)

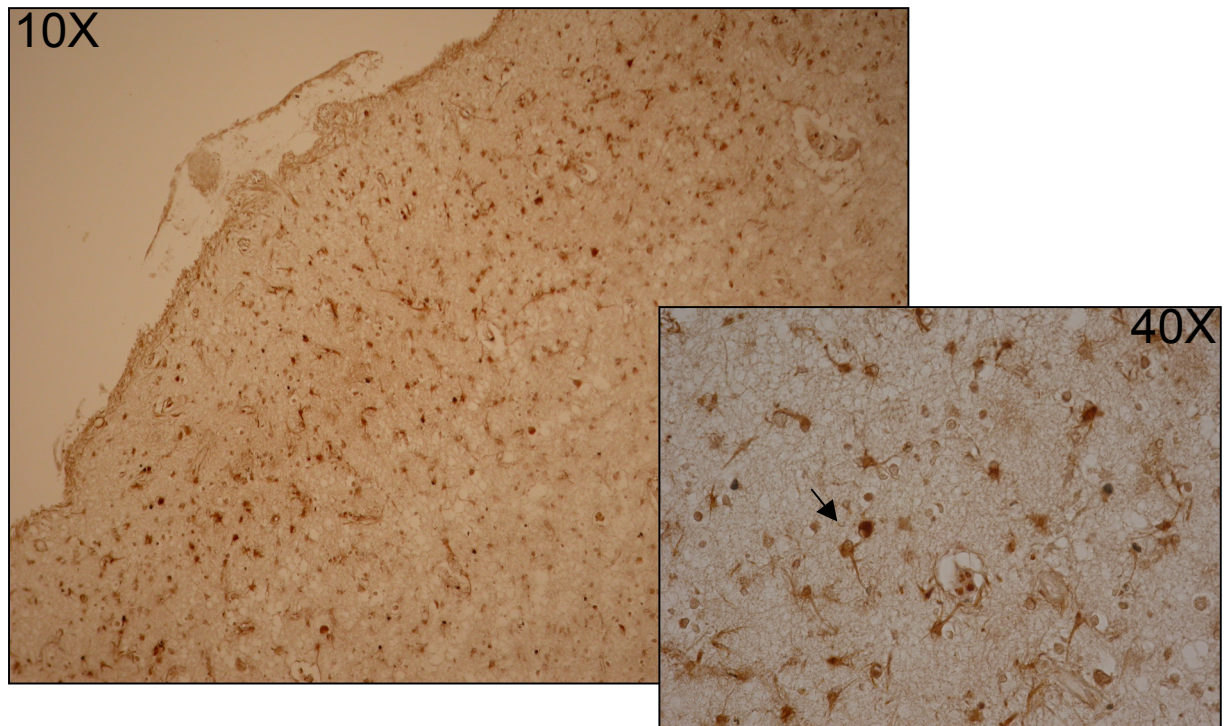

Figure 15b: DAB staining of leptin in hippocampus of an Alzheimer's disease patient.

Figure 16:

a)

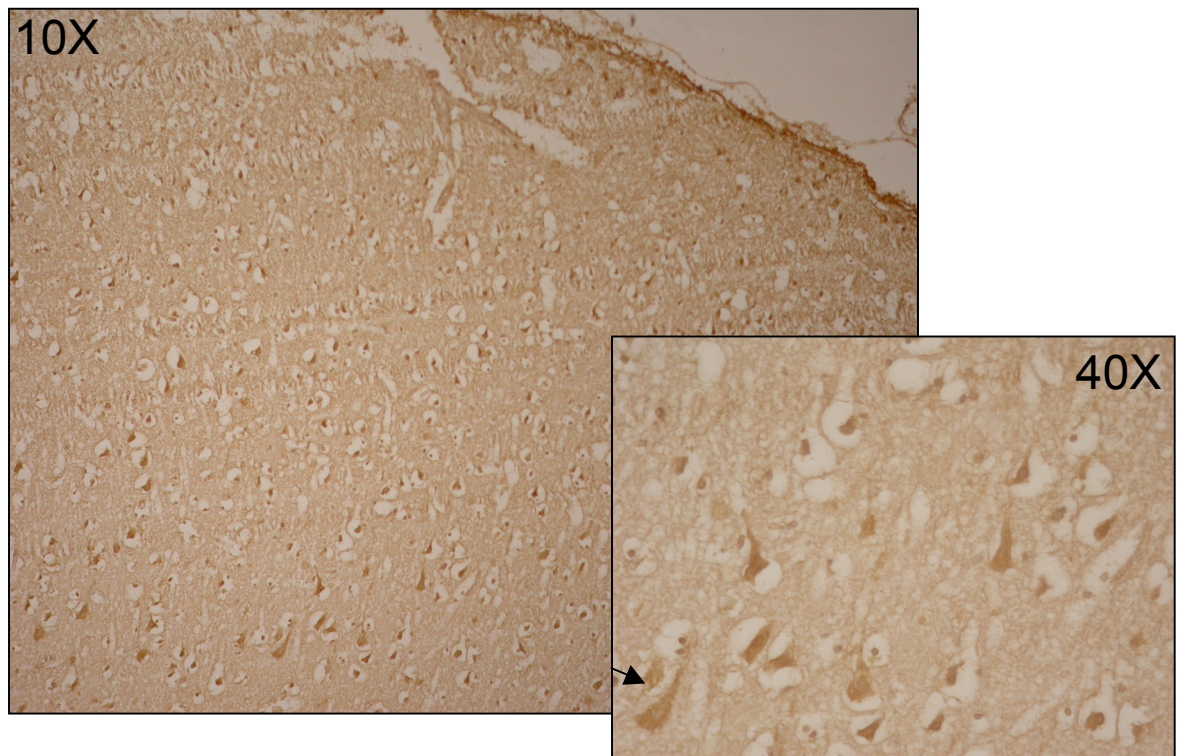

Figure 16a: DAB staining of leptin in frontal cortex of an healthy control.

b)

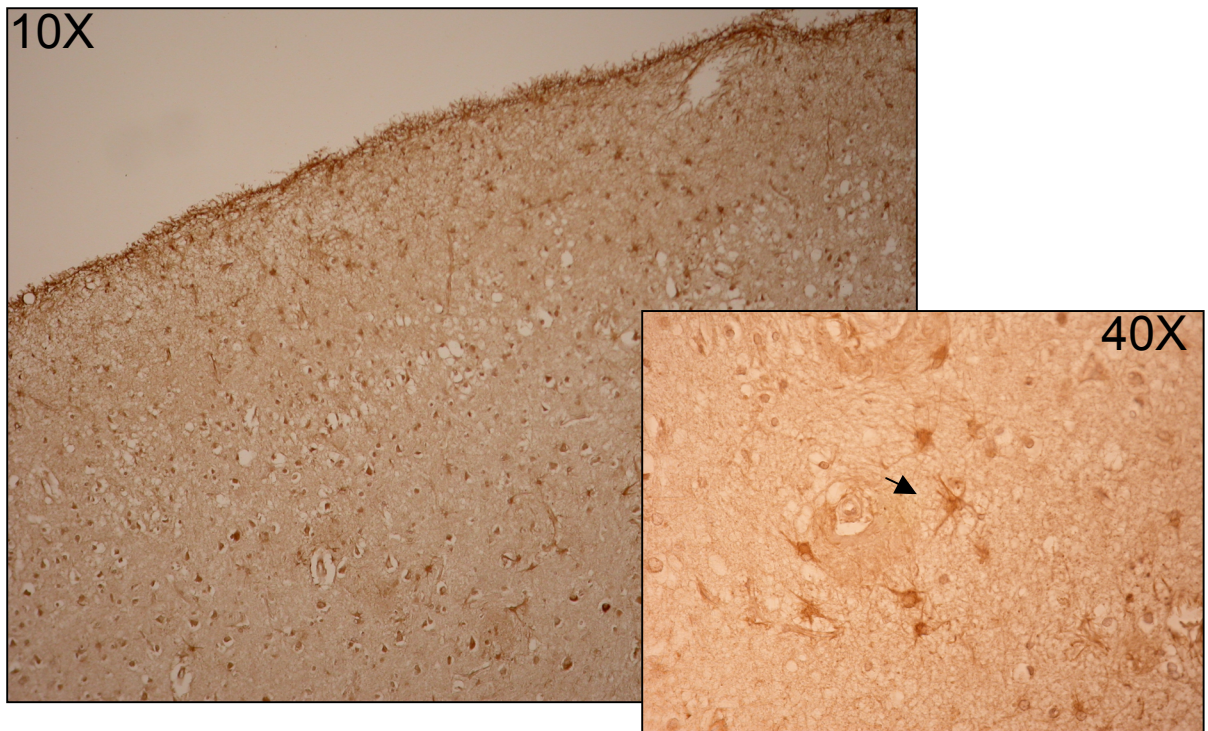

Figure 16b: DAB staining of leptin in frontal cortex of an Alzheimer's disease patient.

Figure 17:

a)

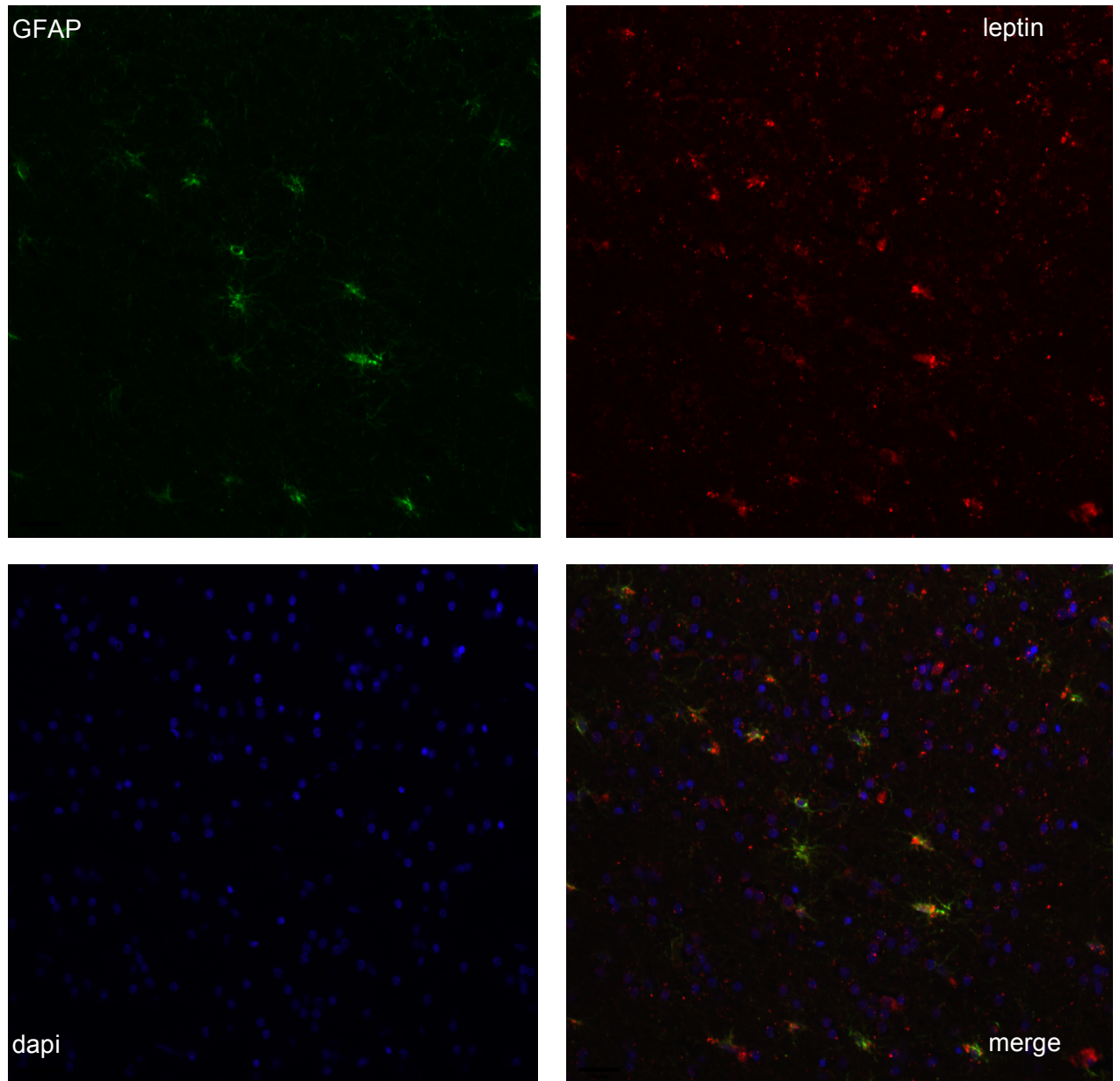

Figure 17a: Double immunofluorescence staining for GFAP and leptin in frontal cortex of an healthy control.

b)

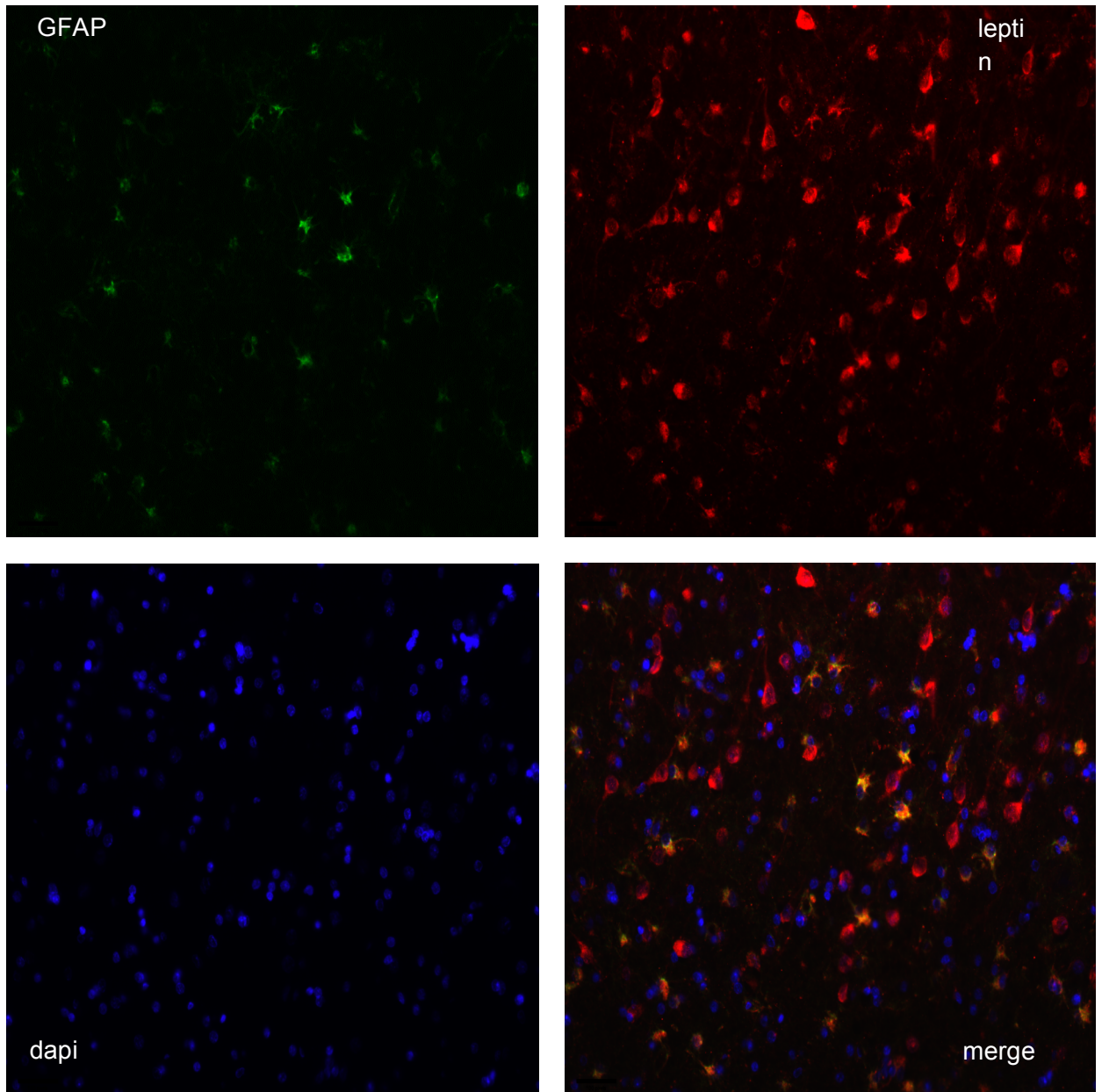
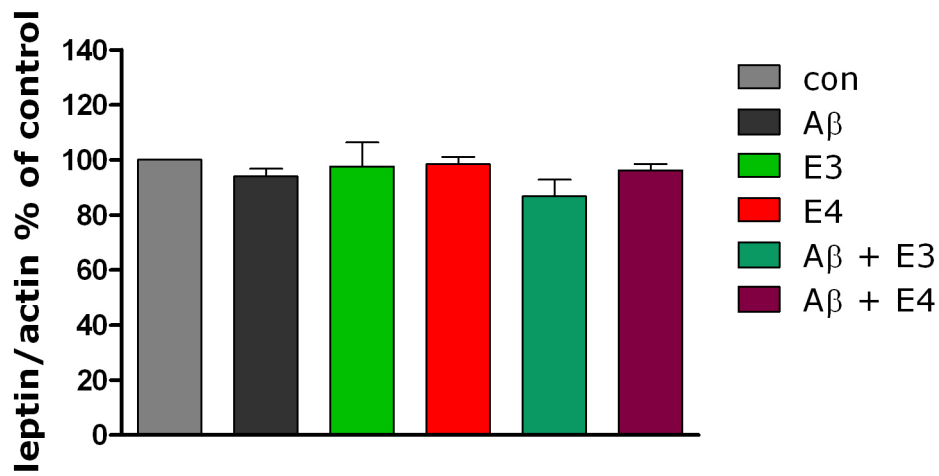

Figure 17b: Double immunofluorescence staining for GFAP and leptin in frontal cortex of Alzheimer's disease patient.

Figure 18:

a)



b)

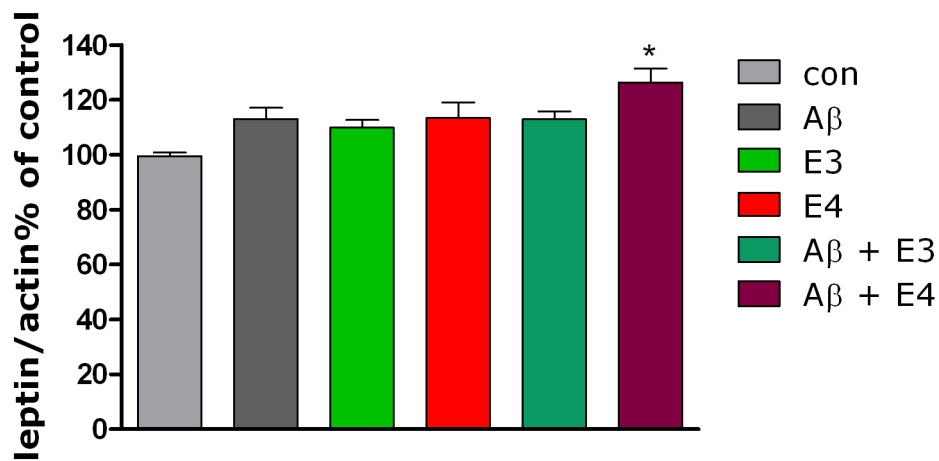

Figure 18: Immunoblotting. Effects on leptin levels after 6 hours (a) and 24 hours (b) of different treatment in lysate of CHME3 human cells.

Data are expressed as percentage of values for untreated cells (con) and represent the mean + SEM of three experiment performed in triplicate.

b) (*P<0.05 vs con)

Figure 19:

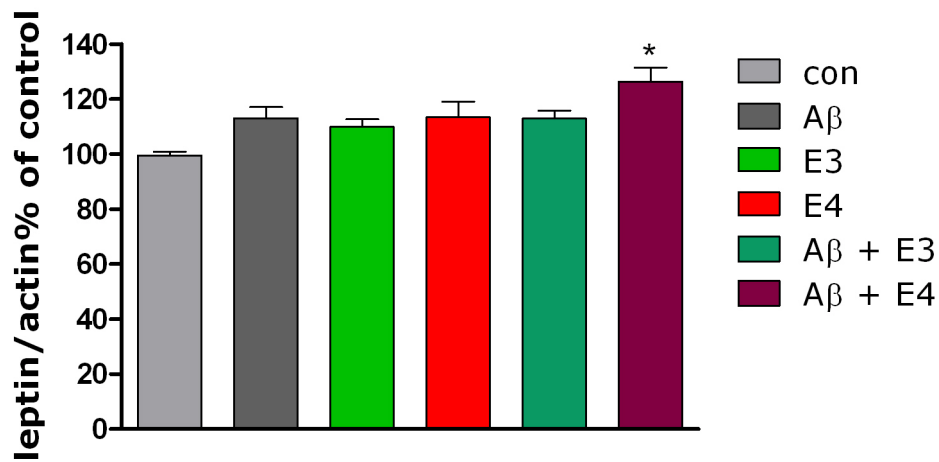

Figure 19: Immunoblotting. Effects on leptin levels after 24 hours of different treatment in lysate of CHME3 human cells.

Data are expressed as percentage of values for untreated cells (con) and represent the mean + SEM.

(*P<0.05 vs con cells)

7. REFERENCES

- 1 Alzheimer, A., Stelzmann, R. A., Schnitzlein, H. N. & Murtagh, F. R. An English translation of Alzheimer's 1907 paper, "Über eine eigenartige Erkankung der Hirnrinde". *Clin Anat* 8, 429-431, doi:10.1002/ca.980080612 (1995).
- 2 Wimo, A., Winblad, B. & Jonsson, L. The worldwide societal costs of dementia: Estimates for 2009. *Alzheimers Dement* 6, 98-103, doi:S1552-5260(10)00015-4 [pii]10.1016/j.jalz.2010.01.010 (2010).
- 3 Querfurth, H. W. & LaFerla, F. M. Alzheimer's disease. *N Engl J Med* 362, 329-344, doi:362/4/329 [pii]10.1056/NEJMra0909142 (2010).
- 4 Hebert, L. E., Scherr, P. A., Bienias, J. L., Bennett, D. A. & Evans, D. A. Alzheimer disease in the US population: prevalence estimates using the 2000 census. *Arch Neurol* 60, 1119-1122, doi:10.1001/archneur.60.8.111960/8/1119 [pii] (2003).
- 5 Welsh, K. A., Butters, N., Hughes, J. P., Mohs, R. C. & Heyman, A. Detection and staging of dementia in Alzheimer's disease. Use of the neuropsychological measures developed for the Consortium to Establish a Registry for Alzheimer's Disease. *Arch Neurol* 49, 448-452 (1992).
- 6 Artero, S., Tierney, M. C., Touchon, J. & Ritchie, K. Prediction of transition from cognitive impairment to senile dementia: a prospective, longitudinal study. *Acta Psychiatr Scand* 107, 390-393, doi:081 [pii] (2003).
- 7 Petersen, R. C. *et al.* Mild cognitive impairment: clinical characterization and outcome. *Arch Neurol* 56, 303-308 (1999).
- 8 Lambon Ralph, M. A., Patterson, K., Graham, N., Dawson, K. & Hodges, J. R. Homogeneity and heterogeneity in mild cognitive impairment and Alzheimer's disease: a cross-sectional and longitudinal study of 55 cases. *Brain* 126, 2350-2362, doi:10.1093/brain/awg236awg236 [pii] (2003).
- 9 Perl, D. P. Neuropathology of Alzheimer's disease. *Mt Sinai J Med* 77, 32-42, doi:10.1002/msj.20157 (2010).
- 10 Braak, H. & Braak, E. Neuropathological stageing of Alzheimer-related changes. *Acta Neuropathol* 82, 239-259 (1991).
- 11 Iversen, L. L., Mortishire-Smith, R. J., Pollack, S. J. & Shearman, M. S. The toxicity in vitro of beta-amyloid protein. *Biochem J* 311 (Pt 1), 1-16 (1995).
- 12 Eikelenboom, P. & van Gool, W. A. Neuroinflammatory perspectives on the two faces of Alzheimer's disease. *J Neural Transm* 111, 281-294, doi:10.1007/s00702-003-0055-1 (2004).
- 13 Hardy, J. & Selkoe, D. J. The amyloid hypothesis of Alzheimer's disease: progress and problems on the road to therapeutics. *Science* 297, 353-356, doi:10.1126/science.1072994297/5580/353 [pii] (2002).
- 14 Selkoe, D. J. The cell biology of beta-amyloid precursor protein and presenilin in Alzheimer's disease. *Trends Cell Biol* 8, 447-453, doi:S0962-8924(98)01363-4 [pii] (1998).
- 15 Shankar, G. M. & Walsh, D. M. Alzheimer's disease: synaptic dysfunction and Abeta. *Mol Neurodegener* 4, 48, doi:1750-1326-4-48 [pii]10.1186/1750-1326-4-48 (2009).
- 16 Burdick, D. *et al.* Assembly and aggregation properties of synthetic Alzheimer's A4/beta amyloid peptide analogs. *J Biol Chem* 267, 546-554 (1992).
- 17 Scheuner, D. *et al.* Secreted amyloid beta-protein similar to that in the senile plaques of Alzheimer's disease is increased in vivo by the presenilin 1 and 2 and APP mutations linked to familial Alzheimer's disease. *Nat Med* 2, 864-870 (1996).

- 18 Iwatsubo, T. *et al.* Visualization of A beta 42(43) and A beta 40 in senile plaques with end-specific A beta monoclonals: evidence that an initially deposited species is A beta 42(43). *Neuron* 13, 45-53, doi:0896-6273(94)90458-8 [pii] (1994).
- 19 Goate, A. *et al.* Segregation of a missense mutation in the amyloid precursor protein gene with familial Alzheimer's disease. *Nature* 349, 704-706, doi:10.1038/349704a0 (1991).
- 20 Rohan de Silva, H. A. *et al.* Cell-specific expression of beta-amyloid precursor protein isoform mRNAs and proteins in neurons and astrocytes. *Brain Res Mol Brain Res* 47, 147-156 (1997).
- 21 Menendez-Gonzalez, M., Perez-Pinera, P., Martinez-Rivera, M., Calatayud, M. T. & Blazquez Menes, B. APP processing and the APP-KPI domain involvement in the amyloid cascade. *Neurodegener Dis* 2, 277-283, doi:00092315 [pii]10.1159/000092315 (2005).
- 22 Bordji, K., Becerril-Ortega, J., Nicole, O. & Buisson, A. Activation of extrasynaptic, but not synaptic, NMDA receptors modifies amyloid precursor protein expression pattern and increases amyloid-ss production. *J Neurosci* 30, 15927-15942, doi:30/47/15927 [pii]10.1523/JNEUROSCI.3021-10.2010 (2010).
- 23 Wasco, W. *et al.* Isolation and characterization of APLP2 encoding a homologue of the Alzheimer's associated amyloid beta protein precursor. *Nat Genet* 5, 95-100, doi:10.1038/ng0993-95 (1993).
- 24 Zheng, H. & Koo, E. H. The amyloid precursor protein: beyond amyloid. *Mol Neurodegener* 1, 5, doi:1750-1326-1-5 [pii]10.1186/1750-1326-1-5 (2006).
- 25 Selkoe, D. J. Clearing the brain's amyloid cobwebs. *Neuron* 32, 177-180, doi:S0896-6273(01)00475-5 [pii] (2001).
- 26 Naslund, J. *et al.* Correlation between elevated levels of amyloid beta-peptide in the brain and cognitive decline. *JAMA* 283, 1571-1577, doi:joc90912 [pii] (2000).
- 27 De Strooper, B., Vassar, R. & Golde, T. The secretases: enzymes with therapeutic potential in Alzheimer disease. *Nat Rev Neurol* 6, 99-107, doi:nrneurol.2009.218 [pii]10.1038/nrneurol.2009.218 (2010).
- 28 Davis, D. G., Schmitt, F. A., Wekstein, D. R. & Markesbery, W. R. Alzheimer neuropathologic alterations in aged cognitively normal subjects. *J Neuropathol Exp Neurol* 58, 376-388 (1999).
- 29 Holmes, C. *et al.* Long-term effects of Abeta42 immunisation in Alzheimer's disease: follow-up of a randomised, placebo-controlled phase I trial. *Lancet* 372, 216-223, doi:S0140-6736(08)61075-2 [pii]10.1016/S0140-6736(08)61075-2 (2008).
- 30 Alafuzoff, I., Iqbal, K., Friden, H., Adolfsson, R. & Winblad, B. Histopathological criteria for progressive dementia disorders: clinical-pathological correlation and classification by multivariate data analysis. *Acta Neuropathol* 74, 209-225 (1987).
- 31 Arriagada, P. V., Growdon, J. H., Hedley-Whyte, E. T. & Hyman, B. T. Neurofibrillary tangles but not senile plaques parallel duration and severity of Alzheimer's disease. *Neurology* 42, 631-639 (1992).
- 32 Iqbal, K. *et al.* Defective brain microtubule assembly in Alzheimer's disease. *Lancet* 2, 421-426 (1986).
- 33 Grundke-Iqbal, I. *et al.* Abnormal phosphorylation of the microtubule-associated protein tau (tau) in Alzheimer cytoskeletal pathology. *Proc Natl Acad Sci U S A* 83, 4913-4917 (1986).
- 34 Grundke-Iqbal, I. *et al.* Microtubule-associated protein tau. A component of Alzheimer paired helical filaments. *J Biol Chem* 261, 6084-6089 (1986).

- 35 Goedert, M., Spillantini, M. G., Jakes, R., Rutherford, D. & Crowther, R. A. Multiple isoforms of human microtubule-associated protein tau: sequences and localization in neurofibrillary tangles of Alzheimer's disease. *Neuron* 3, 519-526, doi:0896-6273(89)90210-9 [pii] (1989).
- 36 Lindwall, G. & Cole, R. D. Phosphorylation affects the ability of tau protein to promote microtubule assembly. *J Biol Chem* 259, 5301-5305 (1984).
- 37 Khatoon, S., Grundke-Iqbal, I. & Iqbal, K. Brain levels of microtubule-associated protein tau are elevated in Alzheimer's disease: a radioimmuno-slot-blot assay for nanograms of the protein. *J Neurochem* 59, 750-753 (1992).
- 38 Johnson, G. V. & Hartigan, J. A. Tau protein in normal and Alzheimer's disease brain: an update. *J Alzheimers Dis* 1, 329-351 (1999).
- 39 Iqbal, K. *et al.* Tau pathology in Alzheimer disease and other tauopathies. *Biochim Biophys Acta* 1739, 198-210, doi:S0925-4439(04)00178-4 [pii]10.1016/j.bbadis.2004.09.008 (2005).
- 40 Pei, J. J. *et al.* Accumulation of cyclin-dependent kinase 5 (cdk5) in neurons with early stages of Alzheimer's disease neurofibrillary degeneration. *Brain Res* 797, 267-277, doi:S0006-8993(98)00296-0 [pii] (1998).
- 41 Pei, J. J. *et al.* Distribution of active glycogen synthase kinase 3beta (GSK-3beta) in brains staged for Alzheimer disease neurofibrillary changes. *J Neuropathol Exp Neurol* 58, 1010-1019 (1999).
- 42 Lovestone, S., Hartley, C. L., Pearce, J. & Anderton, B. H. Phosphorylation of tau by glycogen synthase kinase-3 beta in intact mammalian cells: the effects on the organization and stability of microtubules. *Neuroscience* 73, 1145-1157, doi:0306-4522(96)00126-1 [pii] (1996).
- 43 Lucas, J. J. *et al.* Decreased nuclear beta-catenin, tau hyperphosphorylation and neurodegeneration in GSK-3beta conditional transgenic mice. *EMBO J* 20, 27-39, doi:10.1093/emboj/20.1.27 (2001).
- 44 Kusakawa, G. *et al.* Calpain-dependent proteolytic cleavage of the p35 cyclin-dependent kinase 5 activator to p25. *J Biol Chem* 275, 17166-17172, doi:10.1074/jbc.M907757199M907757199 [pii] (2000).
- 45 Patzke, H. & Tsai, L. H. Calpain-mediated cleavage of the cyclin-dependent kinase-5 activator p39 to p29. *J Biol Chem* 277, 8054-8060, doi:10.1074/jbc.M109645200M109645200 [pii] (2002).
- 46 Cruz, J. C., Tseng, H. C., Goldman, J. A., Shih, H. & Tsai, L. H. Aberrant Cdk5 activation by p25 triggers pathological events leading to neurodegeneration and neurofibrillary tangles. *Neuron* 40, 471-483, doi:S0896627303006275 [pii] (2003).
- 47 Iqbal, K. & Grundke-Iqbal, I. Alzheimer neurofibrillary degeneration: significance, etiopathogenesis, therapeutics and prevention. *J Cell Mol Med* 12, 38-55, doi:JCMM225 [pii]10.1111/j.1582-4934.2008.00225.x (2008).
- 48 Alonso, A. D. *et al.* Phosphorylation of tau at Thr212, Thr231, and Ser262 combined causes neurodegeneration. *J Biol Chem* 285, 30851-30860, doi:M110.110957 [pii]10.1074/jbc.M110.110957 (2010).
- 49 DeKosky, S. T. & Scheff, S. W. Synapse loss in frontal cortex biopsies in Alzheimer's disease: correlation with cognitive severity. *Ann Neurol* 27, 457-464, doi:10.1002/ana.410270502 (1990).
- 50 West, M. J., Coleman, P. D., Flood, D. G. & Troncoso, J. C. Differences in the pattern of hippocampal neuronal loss in normal ageing and Alzheimer's disease. *Lancet* 344, 769-772, doi:S0140-6736(94)92338-8 [pii] (1994).

- 51 Gomez-Isla, T. *et al.* Neuronal loss correlates with but exceeds neurofibrillary tangles in Alzheimer's disease. *Ann Neurol* 41, 17-24, doi:10.1002/ana.410410106 (1997).
- 52 Walsh, D. M. *et al.* Certain inhibitors of synthetic amyloid beta-peptide (Abeta) fibrillogenesis block oligomerization of natural Abeta and thereby rescue long-term potentiation. *J Neurosci* 25, 2455-2462, doi:25/10/2455 [pii]10.1523/JNEUROSCI.4391-04.2005 (2005).
- 53 Larson, J., Lynch, G., Games, D. & Seubert, P. Alterations in synaptic transmission and long-term potentiation in hippocampal slices from young and aged PDAPP mice. *Brain Res* 840, 23-35, doi:S0006-8993(99)01698-4 [pii] (1999).
- 54 Shankar, G. M. *et al.* Natural oligomers of the Alzheimer amyloid-beta protein induce reversible synapse loss by modulating an NMDA-type glutamate receptor-dependent signaling pathway. *J Neurosci* 27, 2866-2875, doi:27/11/2866 [pii]10.1523/JNEUROSCI.4970-06.2007 (2007).
- 55 Snyder, E. M. *et al.* Regulation of NMDA receptor trafficking by amyloid-beta. *Nat Neurosci* 8, 1051-1058, doi:nn1503 [pii]10.1038/nn1503 (2005).
- 56 Hsieh, H. *et al.* AMPAR removal underlies Abeta-induced synaptic depression and dendritic spine loss. *Neuron* 52, 831-843, doi:S0896-6273(06)00872-5 [pii]10.1016/j.neuron.2006.10.035 (2006).
- 57 Mucke, L. *et al.* High-level neuronal expression of abeta 1-42 in wild-type human amyloid protein precursor transgenic mice: synaptotoxicity without plaque formation. *J Neurosci* 20, 4050-4058, doi:20/11/4050 [pii] (2000).
- 58 Terry, R. D. *et al.* Physical basis of cognitive alterations in Alzheimer's disease: synapse loss is the major correlate of cognitive impairment. *Ann Neurol* 30, 572-580, doi:10.1002/ana.410300410 (1991).
- 59 Delacourte, A. *et al.* Nonoverlapping but synergetic tau and APP pathologies in sporadic Alzheimer's disease. *Neurology* 59, 398-407 (2002).
- 60 Barghorn, S. *et al.* Globular amyloid beta-peptide oligomer - a homogenous and stable neuropathological protein in Alzheimer's disease. *J Neurochem* 95, 834-847, doi:JNC3407 [pii]10.1111/j.1471-4159.2005.03407.x (2005).
- 61 Cooper, J. D. *et al.* Failed retrograde transport of NGF in a mouse model of Down's syndrome: reversal of cholinergic neurodegenerative phenotypes following NGF infusion. *Proc Natl Acad Sci U S A* 98, 10439-10444, doi:10.1073/pnas.181219298181219298 [pii] (2001).
- 62 Tuszynski, M. H. Nerve growth factor gene therapy in Alzheimer disease. *Alzheimer Dis Assoc Disord* 21, 179-189, doi:10.1097/WAD.0b013e318068d6d200002093-200704000-00019 [pii] (2007).
- 63 Connor, B. *et al.* Brain-derived neurotrophic factor is reduced in Alzheimer's disease. *Brain Res Mol Brain Res* 49, 71-81 (1997).
- 64 Nagahara, A. H. *et al.* Neuroprotective effects of brain-derived neurotrophic factor in rodent and primate models of Alzheimer's disease. *Nat Med* 15, 331-337, doi:nm.1912 [pii]10.1038/nm.1912 (2009).
- 65 Castren, E. *et al.* The induction of LTP increases BDNF and NGF mRNA but decreases NT-3 mRNA in the dentate gyrus. *Neuroreport* 4, 895-898 (1993).
- 66 Dragunow, M., Hughes, P., Mason-Parker, S. E., Lawlor, P. & Abraham, W. C. TrkB expression in dentate granule cells is associated with a late phase of long-term potentiation. *Brain Res Mol Brain Res* 46, 274-280 (1997).
- 67 Linnarsson, S., Bjorklund, A. & Ernfors, P. Learning deficit in BDNF mutant mice. *Eur J Neurosci* 9, 2581-2587 (1997).

- 68 Minichiello, L. *et al.* Essential role for TrkB receptors in hippocampus-mediated learning. *Neuron* 24, 401-414, doi:S0896-6273(00)80853-3 [pii] (1999).
- 69 Hwang, I. K. *et al.* Correlations between neuronal loss, decrease of memory, and decrease expression of brain-derived neurotrophic factor in the gerbil hippocampus during normal aging. *Exp Neurol* 201, 75-83, doi:S0014-4886(06)00211-1 [pii]10.1016/j.expneurol.2006.02.129 (2006).
- 70 Rex, C. S. *et al.* Brain-derived neurotrophic factor promotes long-term potentiation-related cytoskeletal changes in adult hippocampus. *J Neurosci* 27, 3017-3029, doi:27/11/3017 [pii]10.1523/JNEUROSCI.4037-06.2007 (2007).
- 71 Pang, P. T. & Lu, B. Regulation of late-phase LTP and long-term memory in normal and aging hippocampus: role of secreted proteins tPA and BDNF. *Ageing Res Rev* 3, 407-430, doi:S1568-1637(04)00029-7 [pii]10.1016/j.arr.2004.07.002 (2004).
- 72 Simmons, D. A. *et al.* Up-regulating BDNF with an amphetamine rescues synaptic plasticity and memory in Huntington's disease knockin mice. *Proc Natl Acad Sci U S A* 106, 4906-4911, doi:0811228106 [pii]10.1073/pnas.0811228106 (2009).
- 73 Gooney, M., Messaoudi, E., Maher, F. O., Bramham, C. R. & Lynch, M. A. BDNF-induced LTP in dentate gyrus is impaired with age: analysis of changes in cell signaling events. *Neurobiol Aging* 25, 1323-1331, doi:S0197458004000417 [pii]10.1016/j.neurobiolaging.2004.01.003 (2004).
- 74 Murray, K. D., Gall, C. M., Jones, E. G. & Isackson, P. J. Differential regulation of brain-derived neurotrophic factor and type II calcium/calmodulin-dependent protein kinase messenger RNA expression in Alzheimer's disease. *Neuroscience* 60, 37-48, doi:0306-4522(94)90202-X [pii] (1994).
- 75 Murer, M. G., Yan, Q. & Raisman-Vozari, R. Brain-derived neurotrophic factor in the control human brain, and in Alzheimer's disease and Parkinson's disease. *Prog Neurobiol* 63, 71-124, doi:S0301-0082(00)00014-9 [pii] (2001).
- 76 Garzon, D., Yu, G. & Fahnstock, M. A new brain-derived neurotrophic factor transcript and decrease in brain-derived neurotrophic factor transcripts 1, 2 and 3 in Alzheimer's disease parietal cortex. *J Neurochem* 82, 1058-1064, doi:1030 [pii] (2002).
- 77 Yamamoto-Sasaki, M., Ozawa, H., Saito, T., Rosler, M. & Riederer, P. Impaired phosphorylation of cyclic AMP response element binding protein in the hippocampus of dementia of the Alzheimer type. *Brain Res* 824, 300-303, doi:S0006899399012202 [pii] (1999).
- 78 Elliott, E. & Ginzburg, I. The role of neurotrophins and insulin on tau pathology in Alzheimer's disease. *Rev Neurosci* 17, 635-642 (2006).
- 79 Arancibia, S. *et al.* Protective effect of BDNF against beta-amyloid induced neurotoxicity in vitro and in vivo in rats. *Neurobiol Dis* 31, 316-326, doi:S0969-9961(08)00099-5 [pii]10.1016/j.nbd.2008.05.012 (2008).
- 80 Tapia-Arancibia, L., Aliaga, E., Silhol, M. & Arancibia, S. New insights into brain BDNF function in normal aging and Alzheimer disease. *Brain Res Rev* 59, 201-220, doi:S0165-0173(08)00077-5 [pii]10.1016/j.brainresrev.2008.07.007 (2008).
- 81 Blurton-Jones, M. *et al.* Neural stem cells improve cognition via BDNF in a transgenic model of Alzheimer disease. *Proc Natl Acad Sci U S A* 106, 13594-13599, doi:0901402106 [pii]10.1073/pnas.0901402106 (2009).
- 82 Peng, S., Wu, J., Mufson, E. J. & Fahnstock, M. Precursor form of brain-derived neurotrophic factor and mature brain-derived neurotrophic factor are decreased in the pre-clinical stages of Alzheimer's disease. *J Neurochem* 93, 1412-1421, doi:JNC3135 [pii]10.1111/j.1471-4159.2005.03135.x (2005).

- 83 O'Bryant, S. E. *et al.* Serum Brain-Derived Neurotrophic Factor Levels Are Specifically Associated with Memory Performance among Alzheimer's Disease Cases. *Dement Geriatr Cogn Disord* 31, 31-36, doi:000321980 [pii]10.1159/000321980 (2011).
- 84 Laske, C. *et al.* Higher BDNF serum levels predict slower cognitive decline in Alzheimer's disease patients. *Int J Neuropsychopharmacol*, 1-6, doi:S1461145710001008 [pii]10.1017/S1461145710001008 (2010).
- 85 Mai, L., Jope, R. S. & Li, X. BDNF-mediated signal transduction is modulated by GSK3beta and mood stabilizing agents. *J Neurochem* 82, 75-83 (2002).
- 86 Soontornniyomkij, V. *et al.* Absence of brain-derived neurotrophic factor and trkB receptor immunoreactivity in glia of Alzheimer's disease. *Acta Neuropathol* 98, 345-348, doi:90980345.401 [pii] (1999).
- 87 Murer, M. G. *et al.* An immunohistochemical study of the distribution of brain-derived neurotrophic factor in the adult human brain, with particular reference to Alzheimer's disease. *Neuroscience* 88, 1015-1032, doi:S0306-4522(98)00219-X [pii] (1999).
- 88 Davis, H. P. & Squire, L. R. Protein synthesis and memory: a review. *Psychol Bull* 96, 518-559 (1984).
- 89 Guzowski, J. F. *et al.* Mapping behaviorally relevant neural circuits with immediate-early gene expression. *Curr Opin Neurobiol* 15, 599-606, doi:S0959-4388(05)00136-4 [pii]10.1016/j.conb.2005.08.018 (2005).
- 90 Ramirez-Amaya, V. *et al.* Spatial exploration-induced Arc mRNA and protein expression: evidence for selective, network-specific reactivation. *J Neurosci* 25, 1761-1768, doi:25/7/1761 [pii]10.1523/JNEUROSCI.4342-04.2005 (2005).
- 91 Tagawa, Y., Kanold, P. O., Majdan, M. & Shatz, C. J. Multiple periods of functional ocular dominance plasticity in mouse visual cortex. *Nat Neurosci* 8, 380-388, doi:nn1410 [pii]10.1038/nn1410 (2005).
- 92 Vazdarjanova, A. *et al.* Spatial exploration induces ARC, a plasticity-related immediate-early gene, only in calcium/calmodulin-dependent protein kinase II-positive principal excitatory and inhibitory neurons of the rat forebrain. *J Comp Neurol* 498, 317-329, doi:10.1002/cne.21003 (2006).
- 93 Husi, H., Ward, M. A., Choudhary, J. S., Blackstock, W. P. & Grant, S. G. Proteomic analysis of NMDA receptor-adhesion protein signaling complexes. *Nat Neurosci* 3, 661-669, doi:10.1038/76615 (2000).
- 94 Waltereit, R. *et al.* Arg3.1/Arc mRNA induction by Ca²⁺ and cAMP requires protein kinase A and mitogen-activated protein kinase/extracellular regulated kinase activation. *J Neurosci* 21, 5484-5493, doi:21/15/5484 [pii] (2001).
- 95 Adams, J. P., Robinson, R. A., Hudgins, E. D., Wissink, E. M. & Dudek, S. M. NMDA receptor-independent control of transcription factors and gene expression. *Neuroreport* 20, 1429-1433, doi:10.1097/WNR.0b013e3283311db6 (2009).
- 96 Park, S. *et al.* Elongation factor 2 and fragile X mental retardation protein control the dynamic translation of Arc/Arg3.1 essential for mGluR-LTD. *Neuron* 59, 70-83, doi:S0896-6273(08)00458-3 [pii]10.1016/j.neuron.2008.05.023 (2008).
- 97 Steward, O., Wallace, C. S., Lyford, G. L. & Worley, P. F. Synaptic activation causes the mRNA for the IEG Arc to localize selectively near activated postsynaptic sites on dendrites. *Neuron* 21, 741-751, doi:S0896-6273(00)80591-7 [pii] (1998).
- 98 Plath, N. *et al.* Arc/Arg3.1 is essential for the consolidation of synaptic plasticity and memories. *Neuron* 52, 437-444, doi:S0896-6273(06)00646-5 [pii]10.1016/j.neuron.2006.08.024 (2006).

- 99 Guzewski, J. F. *et al.* Inhibition of activity-dependent arc protein expression in the rat hippocampus impairs the maintenance of long-term potentiation and the consolidation of long-term memory. *J Neurosci* 20, 3993-4001, doi:20/11/3993 [pii] (2000).
- 100 Ploski, J. E. *et al.* The activity-regulated cytoskeletal-associated protein (Arc/Arg3.1) is required for memory consolidation of pavlovian fear conditioning in the lateral amygdala. *J Neurosci* 28, 12383-12395, doi:28/47/12383 [pii]10.1523/JNEUROSCI.1662-08.2008 (2008).
- 101 Venkitaramani, D. V. *et al.* Beta-amyloid modulation of synaptic transmission and plasticity. *J Neurosci* 27, 11832-11837, doi:27/44/11832 [pii]10.1523/JNEUROSCI.3478-07.2007 (2007).
- 102 Lacor, P. N. *et al.* Synaptic targeting by Alzheimer's-related amyloid beta oligomers. *J Neurosci* 24, 10191-10200, doi:24/45/10191 [pii]10.1523/JNEUROSCI.3432-04.2004 (2004).
- 103 Chen, T. J., Wang, D. C. & Chen, S. S. Amyloid-beta interrupts the PI3K-Akt-mTOR signaling pathway that could be involved in brain-derived neurotrophic factor-induced Arc expression in rat cortical neurons. *J Neurosci Res* 87, 2297-2307, doi:10.1002/jnr.22057 (2009).
- 104 Panja, D. *et al.* Novel translational control in Arc-dependent long term potentiation consolidation in vivo. *J Biol Chem* 284, 31498-31511, doi:M109.056077 [pii]10.1074/jbc.M109.056077 (2009).
- 105 Bettens, K., Sleegers, K. & Van Broeckhoven, C. Current status on Alzheimer disease molecular genetics: from past, to present, to future. *Hum Mol Genet* 19, R4-R11, doi:ddq142 [pii]10.1093/hmg/ddq142 (2010).
- 106 Tyrrell, J. *et al.* Dementia in people with Down's syndrome. *Int J Geriatr Psychiatry* 16, 1168-1174, doi:10.1002/gps.502 [pii] (2001).
- 107 Masters, C. L. *et al.* Amyloid plaque core protein in Alzheimer disease and Down syndrome. *Proc Natl Acad Sci U S A* 82, 4245-4249 (1985).
- 108 Mayeux, R. *et al.* The apolipoprotein epsilon 4 allele in patients with Alzheimer's disease. *Ann Neurol* 34, 752-754, doi:10.1002/ana.410340527 (1993).
- 109 Harold, D. *et al.* Genome-wide association study identifies variants at CLU and PICALM associated with Alzheimer's disease. *Nat Genet* 41, 1088-1093, doi:ng.440 [pii]10.1038/ng.440 (2009).
- 110 Pericak-Vance, M. A. *et al.* Linkage studies in familial Alzheimer disease: evidence for chromosome 19 linkage. *Am J Hum Genet* 48, 1034-1050 (1991).
- 111 Corder, E. H. *et al.* Gene dose of apolipoprotein E type 4 allele and the risk of Alzheimer's disease in late onset families. *Science* 261, 921-923 (1993).
- 112 Ashford, J. W. APOE genotype effects on Alzheimer's disease onset and epidemiology. *J Mol Neurosci* 23, 157-165, doi:JMN:23:3:157 [pii]10.1385/JMN:23:3:157 (2004).
- 113 Raber, J., Huang, Y. & Ashford, J. W. ApoE genotype accounts for the vast majority of AD risk and AD pathology. *Neurobiol Aging* 25, 641-650, doi:10.1016/j.neurobiolaging.2003.12.023S0197458004001009 [pii] (2004).
- 114 Cedazo-Minguez, A. Apolipoprotein E and Alzheimer's disease: molecular mechanisms and therapeutic opportunities. *J Cell Mol Med* 11, 1227-1238, doi:JCMM130 [pii]10.1111/j.1582-4934.2007.00130.x (2007).
- 115 Rubinsztein, D. C. & Easton, D. F. Apolipoprotein E genetic variation and Alzheimer's disease. a meta-analysis. *Dement Geriatr Cogn Disord* 10, 199-209, doi:dem10199 [pii] (1999).

- 116 Mahley, R. W. & Huang, Y. Apolipoprotein (apo) E4 and Alzheimer's disease: unique conformational and biophysical properties of apoE4 can modulate neuropathology. *Acta Neurol Scand Suppl* 185, 8-14, doi:ANE679 [pii]10.1111/j.1600-0404.2006.00679.x (2006).
- 117 Mahley, R. W., Nathan, B. P. & Pitas, R. E. Apolipoprotein E. Structure, function, and possible roles in Alzheimer's disease. *Ann N Y Acad Sci* 777, 139-145 (1996).
- 118 Pitas, R. E., Boyles, J. K., Lee, S. H., Foss, D. & Mahley, R. W. Astrocytes synthesize apolipoprotein E and metabolize apolipoprotein E-containing lipoproteins. *Biochim Biophys Acta* 917, 148-161, doi:0005-2760(87)90295-5 [pii] (1987).
- 119 Uchihara, T. *et al.* ApoE immunoreactivity and microglial cells in Alzheimer's disease brain. *Neurosci Lett* 195, 5-8, doi:030439409511763M [pii] (1995).
- 120 Aoki, K. *et al.* Increased expression of neuronal apolipoprotein E in human brain with cerebral infarction. *Stroke* 34, 875-880, doi:10.1161/01.STR.0000064320.73388.C601.STR.0000064320.73388.C6 [pii] (2003).
- 121 Huang, Y., Weisgraber, K. H., Mucke, L. & Mahley, R. W. Apolipoprotein E: diversity of cellular origins, structural and biophysical properties, and effects in Alzheimer's disease. *J Mol Neurosci* 23, 189-204, doi:JMN:23:3:189 [pii]10.1385/JMN:23:3:189 (2004).
- 122 Schmechel, D. E. *et al.* Increased amyloid beta-peptide deposition in cerebral cortex as a consequence of apolipoprotein E genotype in late-onset Alzheimer disease. *Proc Natl Acad Sci U S A* 90, 9649-9653 (1993).
- 123 Dolev, I. & Michaelson, D. M. A nontransgenic mouse model shows inducible amyloid-beta (Abeta) peptide deposition and elucidates the role of apolipoprotein E in the amyloid cascade. *Proc Natl Acad Sci U S A* 101, 13909-13914, doi:10.1073/pnas.04044581010404458101 [pii] (2004).
- 124 Hartman, R. E. *et al.* Apolipoprotein E4 influences amyloid deposition but not cell loss after traumatic brain injury in a mouse model of Alzheimer's disease. *J Neurosci* 22, 10083-10087, doi:22/23/10083 [pii] (2002).
- 125 LaDu, M. J. *et al.* Isoform-specific binding of apolipoprotein E to beta-amyloid. *J Biol Chem* 269, 23403-23406 (1994).
- 126 Bales, K. R. *et al.* Apolipoprotein E is essential for amyloid deposition in the APP(V717F) transgenic mouse model of Alzheimer's disease. *Proc Natl Acad Sci U S A* 96, 15233-15238 (1999).
- 127 Nilsson, L. N. *et al.* Cognitive impairment in PDAPP mice depends on ApoE and ACT-catalyzed amyloid formation. *Neurobiol Aging* 25, 1153-1167, doi:10.1016/j.neurobiolaging.2003.12.011S0197458004000405 [pii] (2004).
- 128 Ye, S. *et al.* Apolipoprotein (apo) E4 enhances amyloid beta peptide production in cultured neuronal cells: apoE structure as a potential therapeutic target. *Proc Natl Acad Sci U S A* 102, 18700-18705, doi:0508693102 [pii]10.1073/pnas.0508693102 (2005).
- 129 Levi, O., Dolev, I., Belinson, H. & Michaelson, D. M. Intraneuronal amyloid-beta plays a role in mediating the synergistic pathological effects of apoE4 and environmental stimulation. *J Neurochem* 103, 1031-1040, doi:JNC4810 [pii]10.1111/j.1471-4159.2007.04810.x (2007).
- 130 Strittmatter, W. J. *et al.* Hypothesis: microtubule instability and paired helical filament formation in the Alzheimer disease brain are related to apolipoprotein E genotype. *Exp Neurol* 125, 163-171; discussion 172-164, doi:S0014488684710193 [pii] (1994).

- 131 Brecht, W. J. *et al.* Neuron-specific apolipoprotein e4 proteolysis is associated with increased tau phosphorylation in brains of transgenic mice. *J Neurosci* 24, 2527-2534, doi:10.1523/JNEUROSCI.4315-03.200424/10/2527 [pii] (2004).
- 132 Rahman, A. *et al.* High cholesterol diet induces tau hyperphosphorylation in apolipoprotein E deficient mice. *FEBS Lett* 579, 6411-6416, doi:S0014-5793(05)01284-6 [pii]10.1016/j.febslet.2005.10.024 (2005).
- 133 Michikawa, M., Fan, Q. W., Isobe, I. & Yanagisawa, K. Apolipoprotein E exhibits isoform-specific promotion of lipid efflux from astrocytes and neurons in culture. *J Neurochem* 74, 1008-1016 (2000).
- 134 Reid, P. C., Urano, Y., Kodama, T. & Hamakubo, T. Alzheimer's disease: cholesterol, membrane rafts, isoprenoids and statins. *J Cell Mol Med* 11, 383-392, doi:JCMM054 [pii]10.1111/j.1582-4934.2007.00054.x (2007).
- 135 Zerbinatti, C. V. & Bu, G. LRP and Alzheimer's disease. *Rev Neurosci* 16, 123-135 (2005).
- 136 Wolozin, B. Cyp46 (24S-cholesterol hydroxylase): a genetic risk factor for Alzheimer disease. *Arch Neurol* 60, 16-18, doi:ned20022 [pii] (2003).
- 137 Abad-Rodriguez, J. *et al.* Neuronal membrane cholesterol loss enhances amyloid peptide generation. *J Cell Biol* 167, 953-960, doi:jcb.200404149 [pii]10.1083/jcb.200404149 (2004).
- 138 Yip, C. M., Elton, E. A., Darabie, A. A., Morrison, M. R. & McLaurin, J. Cholesterol, a modulator of membrane-associated A β -fibrillogenesis and neurotoxicity. *J Mol Biol* 311, 723-734, doi:10.1006/jmbi.2001.4881S0022-2836(01)94881-8 [pii] (2001).
- 139 Buttini, M. *et al.* Expression of human apolipoprotein E3 or E4 in the brains of ApoE^{-/-} mice: isoform-specific effects on neurodegeneration. *J Neurosci* 19, 4867-4880 (1999).
- 140 Arendt, T. Disturbance of neuronal plasticity is a critical pathogenetic event in Alzheimer's disease. *Int J Dev Neurosci* 19, 231-245, doi:S0736-5748(01)00007-7 [pii] (2001).
- 141 Trommer, B. L. *et al.* ApoE isoform affects LTP in human targeted replacement mice. *Neuroreport* 15, 2655-2658, doi:00001756-200412030-00020 [pii] (2004).
- 142 Soininen, H. *et al.* A severe loss of choline acetyltransferase in the frontal cortex of Alzheimer patients carrying apolipoprotein epsilon 4 allele. *Neurosci Lett* 187, 79-82, doi:0304-3940(95)11343-6 [pii] (1995).
- 143 Cedazo-Minguez, A. & Cowburn, R. F. Apolipoprotein E isoform-specific disruption of phosphoinositide hydrolysis: protection by estrogen and glutathione. *FEBS Lett* 504, 45-49, doi:S0014-5793(01)02761-2 [pii] (2001).
- 144 Buttini, M. *et al.* Modulation of Alzheimer-like synaptic and cholinergic deficits in transgenic mice by human apolipoprotein E depends on isoform, aging, and overexpression of amyloid beta peptides but not on plaque formation. *J Neurosci* 22, 10539-10548, doi:22/24/10539 [pii] (2002).
- 145 Cedazo-Minguez, A. *et al.* Apolipoprotein E and beta-amyloid (1-42) regulation of glycogen synthase kinase-3 β . *J Neurochem* 87, 1152-1164, doi:2088 [pii] (2003).
- 146 Hoe, H. S., Harris, D. C. & Rebeck, G. W. Multiple pathways of apolipoprotein E signaling in primary neurons. *J Neurochem* 93, 145-155, doi:JNC3007 [pii]10.1111/j.1471-4159.2004.03007.x (2005).
- 147 Ohkubo, N. *et al.* Apolipoprotein E4 stimulates cAMP response element-binding protein transcriptional activity through the extracellular signal-regulated kinase pathway. *J Biol Chem* 276, 3046-3053, doi:10.1074/jbc.M005070200M005070200 [pii] (2001).

- 148 Xu, P. T. *et al.* A SAGE study of apolipoprotein E3/3, E3/4 and E4/4 allele-specific gene expression in hippocampus in Alzheimer disease. *Mol Cell Neurosci* 36, 313-331, doi:S1044-7431(07)00152-2 [pii]10.1016/j.mcn.2007.06.009 (2007).
- 149 Sporis, D. *et al.* Association of refractory complex partial seizures with a polymorphism of ApoE genotype. *J Cell Mol Med* 9, 698-703, doi:009.003.17 [pii] (2005).
- 150 Huang, Y. Molecular and cellular mechanisms of apolipoprotein E4 neurotoxicity and potential therapeutic strategies. *Curr Opin Drug Discov Devel* 9, 627-641 (2006).
- 151 Buttini, M. *et al.* Dominant negative effects of apolipoprotein E4 revealed in transgenic models of neurodegenerative disease. *Neuroscience* 97, 207-210, doi:S0306-4522(00)00069-5 [pii] (2000).
- 152 Tolar, M. *et al.* Truncated apolipoprotein E (ApoE) causes increased intracellular calcium and may mediate ApoE neurotoxicity. *J Neurosci* 19, 7100-7110 (1999).
- 153 Huang, Y. *et al.* Apolipoprotein E fragments present in Alzheimer's disease brains induce neurofibrillary tangle-like intracellular inclusions in neurons. *Proc Natl Acad Sci U S A* 98, 8838-8843, doi:10.1073/pnas.151254698151254698 [pii] (2001).
- 154 Hatters, D. M., Zhong, N., Rutenber, E. & Weisgraber, K. H. Amino-terminal domain stability mediates apolipoprotein E aggregation into neurotoxic fibrils. *J Mol Biol* 361, 932-944, doi:S0022-2836(06)00837-0 [pii]10.1016/j.jmb.2006.06.080 (2006).
- 155 Mayeux, R. *et al.* Synergistic effects of traumatic head injury and apolipoprotein-epsilon 4 in patients with Alzheimer's disease. *Neurology* 45, 555-557 (1995).
- 156 Breteler, M. M. Vascular risk factors for Alzheimer's disease: an epidemiologic perspective. *Neurobiol Aging* 21, 153-160, doi:S0197-4580(99)00110-4 [pii] (2000).
- 157 Honig, L. S. *et al.* Stroke and the risk of Alzheimer disease. *Arch Neurol* 60, 1707-1712, doi:10.1001/archneur.60.12.170760/12/1707 [pii] (2003).
- 158 Luchsinger, J. A., Tang, M. X., Shea, S. & Mayeux, R. Hyperinsulinemia and risk of Alzheimer disease. *Neurology* 63, 1187-1192, doi:63/7/1187 [pii] (2004).
- 159 Peila, R., Rodriguez, B. L. & Launer, L. J. Type 2 diabetes, APOE gene, and the risk for dementia and related pathologies: The Honolulu-Asia Aging Study. *Diabetes* 51, 1256-1262 (2002).
- 160 Pendlebury, S. T. & Rothwell, P. M. Prevalence, incidence, and factors associated with pre-stroke and post-stroke dementia: a systematic review and meta-analysis. *Lancet Neurol* 8, 1006-1018, doi:S1474-4422(09)70236-4 [pii]10.1016/S1474-4422(09)70236-4 (2009).
- 161 Cheung, Z. H., Gong, K. & Ip, N. Y. Cyclin-dependent kinase 5 supports neuronal survival through phosphorylation of Bcl-2. *J Neurosci* 28, 4872-4877, doi:28/19/4872 [pii]10.1523/JNEUROSCI.0689-08.2008 (2008).
- 162 Deane, R., Wu, Z. & Zlokovic, B. V. RAGE (yin) versus LRP (yang) balance regulates alzheimer amyloid beta-peptide clearance through transport across the blood-brain barrier. *Stroke* 35, 2628-2631, doi:10.1161/01.STR.0000143452.85382.d101.STR.0000143452.85382.d1 [pii] (2004).
- 163 Forette, F. *et al.* The prevention of dementia with antihypertensive treatment: new evidence from the Systolic Hypertension in Europe (Syst-Eur) study. *Arch Intern Med* 162, 2046-2052, doi:ioi10730 [pii] (2002).
- 164 Tzourio, C. *et al.* Effects of blood pressure lowering with perindopril and indapamide therapy on dementia and cognitive decline in patients with cerebrovascular disease. *Arch Intern Med* 163, 1069-1075, doi:10.1001/archinte.163.9.1069163/9/1069 [pii] (2003).

- 165 Luchsinger, J. A., Tang, M. X., Stern, Y., Shea, S. & Mayeux, R. Diabetes mellitus and risk of Alzheimer's disease and dementia with stroke in a multiethnic cohort. *Am J Epidemiol* 154, 635-641 (2001).
- 166 Craft, S. Insulin resistance and Alzheimer's disease pathogenesis: potential mechanisms and implications for treatment. *Curr Alzheimer Res* 4, 147-152 (2007).
- 167 Cook, D. G. *et al.* Reduced hippocampal insulin-degrading enzyme in late-onset Alzheimer's disease is associated with the apolipoprotein E-epsilon4 allele. *Am J Pathol* 162, 313-319 (2003).
- 168 Yan, S. D. *et al.* RAGE and amyloid-beta peptide neurotoxicity in Alzheimer's disease. *Nature* 382, 685-691, doi:10.1038/382685a0 (1996).
- 169 Kuo, Y. M. *et al.* Elevated low-density lipoprotein in Alzheimer's disease correlates with brain abeta 1-42 levels. *Biochem Biophys Res Commun* 252, 711-715, doi:S0006-291X(98)99652-8 [pii]10.1006/bbrc.1998.9652 (1998).
- 170 Michikawa, M. Cholesterol paradox: is high total or low HDL cholesterol level a risk for Alzheimer's disease? *J Neurosci Res* 72, 141-146, doi:10.1002/jnr.10585 (2003).
- 171 Sano, M. *et al.* A multi-center, randomized, double blind placebo-controlled trial of estrogens to prevent Alzheimer's disease and loss of memory in women: design and baseline characteristics. *Clin Trials* 5, 523-533, doi:5/5/523 [pii]10.1177/1740774508096313 (2008).
- 172 Cataldo, J. K., Prochaska, J. J. & Glantz, S. A. Cigarette smoking is a risk factor for Alzheimer's Disease: an analysis controlling for tobacco industry affiliation. *J Alzheimers Dis* 19, 465-480, doi:X880352113361JK4 [pii]10.3233/JAD-2010-1240 (2010).
- 173 Jorm, A. F. History of depression as a risk factor for dementia: an updated review. *Aust N Z J Psychiatry* 35, 776-781 (2001).
- 174 Panza, F. *et al.* Impact of depressive symptoms on the rate of progression to dementia in patients affected by mild cognitive impairment. The Italian Longitudinal Study on Aging. *Int J Geriatr Psychiatry* 23, 726-734, doi:10.1002/gps.1967 (2008).
- 175 Aleisa, A. M., Alzoubi, K. H., Gerges, N. Z. & Alkadhi, K. A. Chronic psychosocial stress-induced impairment of hippocampal LTP: possible role of BDNF. *Neurobiol Dis* 22, 453-462, doi:S0969-9961(05)00341-4 [pii]10.1016/j.nbd.2005.12.005 (2006).
- 176 Fratiglioni, L., Paillard-Borg, S. & Winblad, B. An active and socially integrated lifestyle in late life might protect against dementia. *Lancet Neurol* 3, 343-353, doi:10.1016/S1474-4422(04)00767-7S1474442204007677 [pii] (2004).
- 177 Colcombe, S. & Kramer, A. F. Fitness effects on the cognitive function of older adults: a meta-analytic study. *Psychol Sci* 14, 125-130 (2003).
- 178 Fratiglioni, L. & Wang, H. X. Brain reserve hypothesis in dementia. *J Alzheimers Dis* 12, 11-22 (2007).
- 179 Acevedo, A. & Loewenstein, D. A. Nonpharmacological cognitive interventions in aging and dementia. *J Geriatr Psychiatry Neurol* 20, 239-249, doi:20/4/239 [pii]10.1177/0891988707308808 (2007).
- 180 Hendrie, H. C. *et al.* Prevalence of Alzheimer's disease and dementia in two communities: Nigerian Africans and African Americans. *Am J Psychiatry* 152, 1485-1492 (1995).
- 181 Graves, A. B. *et al.* Prevalence of dementia and its subtypes in the Japanese American population of King County, Washington state. The Kame Project. *Am J Epidemiol* 144, 760-771 (1996).
- 182 Kalmijn, S. *et al.* Dietary fat intake and the risk of incident dementia in the Rotterdam Study. *Ann Neurol* 42, 776-782, doi:10.1002/ana.410420514 (1997).

- 183 Morris, M. C. *et al.* Dietary intake of antioxidant nutrients and the risk of incident Alzheimer disease in a biracial community study. *JAMA* 287, 3230-3237, doi:joc11570 [pii] (2002).
- 184 Engelhart, M. J. *et al.* Dietary intake of antioxidants and risk of Alzheimer disease. *JAMA* 287, 3223-3229, doi:joc12012 [pii] (2002).
- 185 Laurin, D., Masaki, K. H., Foley, D. J., White, L. R. & Launer, L. J. Midlife dietary intake of antioxidants and risk of late-life incident dementia: the Honolulu-Asia Aging Study. *Am J Epidemiol* 159, 959-967 (2004).
- 186 Engelhart, M. J. *et al.* Diet and risk of dementia: Does fat matter?: The Rotterdam Study. *Neurology* 59, 1915-1921 (2002).
- 187 Scarmeas, N., Stern, Y., Tang, M. X., Mayeux, R. & Luchsinger, J. A. Mediterranean diet and risk for Alzheimer's disease. *Ann Neurol* 59, 912-921, doi:10.1002/ana.20854 (2006).
- 188 Scarmeas, N. *et al.* Mediterranean diet and mild cognitive impairment. *Arch Neurol* 66, 216-225, doi:66/2/216 [pii]10.1001/archneurol.2008.536 (2009).
- 189 Chiu, C. C. *et al.* The effects of omega-3 fatty acids monotherapy in Alzheimer's disease and mild cognitive impairment: a preliminary randomized double-blind placebo-controlled study. *Prog Neuropsychopharmacol Biol Psychiatry* 32, 1538-1544, doi:S0278-5846(08)00150-4 [pii]10.1016/j.pnpbp.2008.05.015 (2008).
- 190 Freund-Levi, Y. *et al.* Effects of omega-3 fatty acids on inflammatory markers in cerebrospinal fluid and plasma in Alzheimer's disease: the OmegAD study. *Dement Geriatr Cogn Disord* 27, 481-490, doi:000218081 [pii]10.1159/000218081 (2009).
- 191 Nagano, S. *et al.* Peroxidase activity of cyclooxygenase-2 (COX-2) cross-links beta-amyloid (Abeta) and generates Abeta-COX-2 hetero-oligomers that are increased in Alzheimer's disease. *J Biol Chem* 279, 14673-14678, doi:10.1074/jbc.M313003200M313003200 [pii] (2004).
- 192 Butterfield, D. A., Castegna, A., Drake, J., Scapagnini, G. & Calabrese, V. Vitamin E and neurodegenerative disorders associated with oxidative stress. *Nutr Neurosci* 5, 229-239 (2002).
- 193 Pardo, B., Mena, M. A., Fahn, S. & Garcia de Yebenes, J. Ascorbic acid protects against levodopa-induced neurotoxicity on a catecholamine-rich human neuroblastoma cell line. *Mov Disord* 8, 278-284, doi:10.1002/mds.870080305 (1993).
- 194 Voko, Z., Hollander, M., Hofman, A., Koudstaal, P. J. & Breteler, M. M. Dietary antioxidants and the risk of ischemic stroke: the Rotterdam Study. *Neurology* 61, 1273-1275 (2003).
- 195 Yehuda, S., Rabinovitz, S., Carasso, R. L. & Mostofsky, D. I. The role of polyunsaturated fatty acids in restoring the aging neuronal membrane. *Neurobiol Aging* 23, 843-853, doi:S019745800200074X [pii] (2002).
- 196 Morris, M. C., Evans, D. A., Bienias, J. L., Tangney, C. C. & Wilson, R. S. Dietary fat intake and 6-year cognitive change in an older biracial community population. *Neurology* 62, 1573-1579 (2004).
- 197 Coscina, D. V., Yehuda, S., Dixon, L. M., Kish, S. J. & Leprohon-Greenwood, C. E. Learning is improved by a soybean oil diet in rats. *Life Sci* 38, 1789-1794 (1986).
- 198 Winocur, G. & Greenwood, C. E. Studies of the effects of high fat diets on cognitive function in a rat model. *Neurobiol Aging* 26 Suppl 1, 46-49, doi:S0197-4580(05)00264-2 [pii]10.1016/j.neurobiolaging.2005.09.003 (2005).
- 199 Van der Auwera, I., Wera, S., Van Leuven, F. & Henderson, S. T. A ketogenic diet reduces amyloid beta 40 and 42 in a mouse model of Alzheimer's disease. *Nutr Metab (Lond)* 2, 28, doi:1743-7075-2-28 [pii]10.1186/1743-7075-2-28 (2005).

- 200 Kivipelto, M. *et al.* Apolipoprotein E epsilon4 magnifies lifestyle risks for dementia: a population-based study. *J Cell Mol Med* 12, 2762-2771, doi:JCMM296 [pii]10.1111/j.1582-4934.2008.00296.x (2008).
- 201 Clandinin, M. T., Cheema, S., Field, C. J. & Baracos, V. E. Dietary lipids influence insulin action. *Ann N Y Acad Sci* 683, 151-163 (1993).
- 202 Manco, M., Calvani, M. & Mingrone, G. Effects of dietary fatty acids on insulin sensitivity and secretion. *Diabetes Obes Metab* 6, 402-413, doi:DOM356 [pii]10.1111/j.1462-8902.2004.00356.x (2004).
- 203 Holness, M. J., Greenwood, G. K., Smith, N. D. & Sugden, M. C. Diabetogenic impact of long-chain omega-3 fatty acids on pancreatic beta-cell function and the regulation of endogenous glucose production. *Endocrinology* 144, 3958-3968 (2003).
- 204 Wu, C. W. *et al.* Brain region-dependent increases in beta-amyloid and apolipoprotein E levels in hypercholesterolemic rabbits. *J Neural Transm* 110, 641-649, doi:10.1007/s00702-002-0809-1 (2003).
- 205 Sparks, D. L., Martins, R. & Martin, T. Cholesterol and cognition: rationale for the AD cholesterol-lowering treatment trial and sex-related Differences in beta-amyloid accumulation in the brains of spontaneously hypercholesterolemic Watanabe rabbits. *Ann N Y Acad Sci* 977, 356-366 (2002).
- 206 Refolo, L. M. *et al.* Hypercholesterolemia accelerates the Alzheimer's amyloid pathology in a transgenic mouse model. *Neurobiol Dis* 7, 321-331, doi:10.1006/nbdi.2000.0304S0969-9961(00)90304-8 [pii] (2000).
- 207 Wang, J. *et al.* Caloric restriction attenuates beta-amyloid neuropathology in a mouse model of Alzheimer's disease. *FASEB J* 19, 659-661, doi:04-3182fje [pii]10.1096/fj.04-3182fje (2005).
- 208 Elias, M. F., Elias, P. K., Sullivan, L. M., Wolf, P. A. & D'Agostino, R. B. Lower cognitive function in the presence of obesity and hypertension: the Framingham heart study. *Int J Obes Relat Metab Disord* 27, 260-268, doi:10.1038/sj.ijo.802225802225 [pii] (2003).
- 209 Burns, M. P. *et al.* Co-localization of cholesterol, apolipoprotein E and fibrillar Abeta in amyloid plaques. *Brain Res Mol Brain Res* 110, 119-125, doi:S0169328X02006472 [pii] (2003).
- 210 Bieschke, J., Zhang, Q., Powers, E. T., Lerner, R. A. & Kelly, J. W. Oxidative metabolites accelerate Alzheimer's amyloidogenesis by a two-step mechanism, eliminating the requirement for nucleation. *Biochemistry* 44, 4977-4983, doi:10.1021/bi0501030 (2005).
- 211 Wolozin, B., Brown, J., 3rd, Theisler, C. & Silberman, S. The cellular biochemistry of cholesterol and statins: insights into the pathophysiology and therapy of Alzheimer's disease. *CNS Drug Rev* 10, 127-146 (2004).
- 212 Schonknecht, P. *et al.* Cerebrospinal fluid 24S-hydroxycholesterol is increased in patients with Alzheimer's disease compared to healthy controls. *Neurosci Lett* 324, 83-85, doi:S0304394002001647 [pii] (2002).
- 213 Papassotiropoulos, A. *et al.* Plasma 24S-hydroxycholesterol: a peripheral indicator of neuronal degeneration and potential state marker for Alzheimer's disease. *Neuroreport* 11, 1959-1962 (2000).
- 214 Chalmers, K. A. *et al.* APOE promoter, ACE1 and CYP46 polymorphisms and beta-amyloid in Alzheimer's disease. *Neuroreport* 15, 95-98 (2004).
- 215 Johansson, A. *et al.* Variants of CYP46A1 may interact with age and APOE to influence CSF Abeta42 levels in Alzheimer's disease. *Hum Genet* 114, 581-587, doi:10.1007/s00439-004-1107-9 (2004).

- 216 Desai, P., DeKosky, S. T. & Kamboh, M. I. Genetic variation in the cholesterol 24-hydroxylase (CYP46) gene and the risk of Alzheimer's disease. *Neurosci Lett* 328, 9-12, doi:S0304394002004433 [pii] (2002).
- 217 Vance, J. E., Hayashi, H. & Karten, B. Cholesterol homeostasis in neurons and glial cells. *Semin Cell Dev Biol* 16, 193-212, doi:S1084-9521(05)00021-2 [pii]10.1016/j.semcdb.2005.01.005 (2005).
- 218 Oner, P., Bekpinar, S. & Oz, B. Alterations in some lipid components and Ca²⁺ ATPase activity in brain of rats fed an atherogenic diet. *Res Commun Chem Pathol Pharmacol* 72, 337-345 (1991).
- 219 Dehouck, B. *et al.* A new function for the LDL receptor: transcytosis of LDL across the blood-brain barrier. *J Cell Biol* 138, 877-889 (1997).
- 220 Henderson, S. T. High carbohydrate diets and Alzheimer's disease. *Med Hypotheses* 62, 689-700, doi:10.1016/j.mehy.2003.11.028S0306987704000167 [pii] (2004).
- 221 Corbo, R. M. & Scacchi, R. Apolipoprotein E (APOE) allele distribution in the world. Is APOE*4 a 'thrifty' allele? *Ann Hum Genet* 63, 301-310 (1999).
- 222 Osuntokun, B. O. *et al.* Lack of an association between apolipoprotein E epsilon 4 and Alzheimer's disease in elderly Nigerians. *Ann Neurol* 38, 463-465, doi:10.1002/ana.410380319 (1995).
- 223 Bray, G. A., Nielsen, S. J. & Popkin, B. M. Consumption of high-fructose corn syrup in beverages may play a role in the epidemic of obesity. *Am J Clin Nutr* 79, 537-543 (2004).
- 224 Craft, S. *et al.* Cerebrospinal fluid and plasma insulin levels in Alzheimer's disease: relationship to severity of dementia and apolipoprotein E genotype. *Neurology* 50, 164-168 (1998).
- 225 Messier, C. & Teutenberg, K. The role of insulin, insulin growth factor, and insulin-degrading enzyme in brain aging and Alzheimer's disease. *Neural Plast* 12, 311-328, doi:10.1155/NP.2005.311 (2005).
- 226 Wu, W. *et al.* The brain in the age of old: the hippocampal formation is targeted differentially by diseases of late life. *Ann Neurol* 64, 698-706, doi:10.1002/ana.21557 (2008).
- 227 Takashima, A. GSK-3 is essential in the pathogenesis of Alzheimer's disease. *J Alzheimers Dis* 9, 309-317 (2006).
- 228 Haan, M. N., Shemanski, L., Jagust, W. J., Manolio, T. A. & Kuller, L. The role of APOE epsilon4 in modulating effects of other risk factors for cognitive decline in elderly persons. *JAMA* 282, 40-46, doi:joc81663 [pii] (1999).
- 229 Fewlass, D. C. *et al.* Obesity-related leptin regulates Alzheimer's Abeta. *FASEB J* 18, 1870-1878, doi:18/15/1870 [pii]10.1096/fj.04-2572com (2004).
- 230 Zhang, Y. *et al.* Positional cloning of the mouse obese gene and its human homologue. *Nature* 372, 425-432, doi:10.1038/372425a0 (1994).
- 231 Halaas, J. L. *et al.* Weight-reducing effects of the plasma protein encoded by the obese gene. *Science* 269, 543-546 (1995).
- 232 Fujioka, K., Patane, J., Lubina, J. & Lau, D. CSF leptin levels after exogenous administration of recombinant methionyl human leptin. *JAMA* 282, 1517-1518, doi:jlt1027 [pii] (1999).
- 233 Hwa, J. J., Ghibaudi, L., Compton, D., Fawzi, A. B. & Strader, C. D. Intracerebroventricular injection of leptin increases thermogenesis and mobilizes fat metabolism in ob/ob mice. *Horm Metab Res* 28, 659-663, doi:10.1055/s-2007-979873 (1996).

- 234 Shimomura, I., Hammer, R. E., Ikemoto, S., Brown, M. S. & Goldstein, J. L. Leptin reverses insulin resistance and diabetes mellitus in mice with congenital lipodystrophy. *Nature* 401, 73-76, doi:10.1038/43448 (1999).
- 235 Shanley, L. J., Irving, A. J. & Harvey, J. Leptin enhances NMDA receptor function and modulates hippocampal synaptic plasticity. *J Neurosci* 21, RC186, doi:20015885 [pii] (2001).
- 236 Zhang, F., Wang, S., Signore, A. P. & Chen, J. Neuroprotective effects of leptin against ischemic injury induced by oxygen-glucose deprivation and transient cerebral ischemia. *Stroke* 38, 2329-2336, doi:STROKEAHA.107.482786 [pii]10.1161/STROKEAHA.107.482786 (2007).
- 237 Maresh, G. A., Maness, L. M., Zadina, J. E. & Kastin, A. J. In vitro demonstration of a saturable transport system for leptin across the blood-brain barrier. *Life Sci* 69, 67-73 (2001).
- 238 Morash, B., Li, A., Murphy, P. R., Wilkinson, M. & Ur, E. Leptin gene expression in the brain and pituitary gland. *Endocrinology* 140, 5995-5998 (1999).
- 239 Banks, W. A. *et al.* Triglycerides induce leptin resistance at the blood-brain barrier. *Diabetes* 53, 1253-1260 (2004).
- 240 Schwartz, M. W., Seeley, R. J., Campfield, L. A., Burn, P. & Baskin, D. G. Identification of targets of leptin action in rat hypothalamus. *J Clin Invest* 98, 1101-1106, doi:10.1172/JCI118891 (1996).
- 241 Tartaglia, L. A. The leptin receptor. *J Biol Chem* 272, 6093-6096 (1997).
- 242 Ge, H., Huang, L., Pourbahrami, T. & Li, C. Generation of soluble leptin receptor by ectodomain shedding of membrane-spanning receptors in vitro and in vivo. *J Biol Chem* 277, 45898-45903, doi:10.1074/jbc.M205825200M205825200 [pii] (2002).
- 243 Signore, A. P., Zhang, F., Weng, Z., Gao, Y. & Chen, J. Leptin neuroprotection in the CNS: mechanisms and therapeutic potentials. *J Neurochem* 106, 1977-1990, doi:JNC5457 [pii]10.1111/j.1471-4159.2008.05457.x (2008).
- 244 Bjorbaek, C., Elmquist, J. K., Frantz, J. D., Shoelson, S. E. & Flier, J. S. Identification of SOCS-3 as a potential mediator of central leptin resistance. *Mol Cell* 1, 619-625, doi:S1097-2765(00)80062-3 [pii] (1998).
- 245 Kola, B., Boscaro, M., Rutter, G. A., Grossman, A. B. & Korbonits, M. Expanding role of AMPK in endocrinology. *Trends Endocrinol Metab* 17, 205-215, doi:S1043-2760(06)00084-1 [pii]10.1016/j.tem.2006.05.006 (2006).
- 246 Long, Y. C. & Zierath, J. R. AMP-activated protein kinase signaling in metabolic regulation. *J Clin Invest* 116, 1776-1783, doi:10.1172/JCI29044 (2006).
- 247 Tezapsidis, N. *et al.* Leptin: a novel therapeutic strategy for Alzheimer's disease. *J Alzheimers Dis* 16, 731-740, doi:3375752606620632 [pii]10.3233/JAD-2009-1021 (2009).
- 248 Greco, S. J. *et al.* Leptin inhibits glycogen synthase kinase-3beta to prevent tau phosphorylation in neuronal cells. *Neurosci Lett* 455, 191-194, doi:S0304-3940(09)00364-4 [pii]10.1016/j.neulet.2009.03.066 (2009).
- 249 Greco, S. J. *et al.* Leptin reduces Alzheimer's disease-related tau phosphorylation in neuronal cells. *Biochem Biophys Res Commun* 376, 536-541, doi:S0006-291X(08)01768-3 [pii]10.1016/j.bbrc.2008.09.026 (2008).
- 250 Pinto, S. *et al.* Rapid rewiring of arcuate nucleus feeding circuits by leptin. *Science* 304, 110-115, doi:10.1126/science.1089459304/5667/110 [pii] (2004).
- 251 O'Malley, D. *et al.* Leptin promotes rapid dynamic changes in hippocampal dendritic morphology. *Mol Cell Neurosci* 35, 559-572, doi:S1044-7431(07)00110-8 [pii]10.1016/j.mcn.2007.05.001 (2007).

- 252 Li, X. L. *et al.* Impairment of long-term potentiation and spatial memory in leptin receptor-deficient rodents. *Neuroscience* 113, 607-615, doi:S0306452202001628 [pii] (2002).
- 253 Greco, S. J. *et al.* Leptin reduces pathology and improves memory in a transgenic mouse model of Alzheimer's disease. *J Alzheimers Dis* 19, 1155-1167, doi:075885178N117810 [pii]10.3233/JAD-2010-1308 (2010).
- 254 Lieb, W. *et al.* Association of plasma leptin levels with incident Alzheimer disease and MRI measures of brain aging. *JAMA* 302, 2565-2572, doi:302/23/2565 [pii]10.1001/jama.2009.1836 (2009).
- 255 Dawber, T. R., Meadors, G. F. & Moore, F. E., Jr. Epidemiological approaches to heart disease: the Framingham Study. *Am J Public Health Nations Health* 41, 279-281 (1951).
- 256 Paz-Filho, G., Wong, M. L. & Licinio, J. Leptin levels and Alzheimer disease. *JAMA* 303, 1478; author reply 1478-1479, doi:303/15/1478 [pii]10.1001/jama.2010.436 (2010).
- 257 Power, D. A., Noel, J., Collins, R. & O'Neill, D. Circulating leptin levels and weight loss in Alzheimer's disease patients. *Dement Geriatr Cogn Disord* 12, 167-170, doi:dem12167 [pii] (2001).
- 258 Farlow, M. R. & Cummings, J. L. Effective pharmacologic management of Alzheimer's disease. *Am J Med* 120, 388-397, doi:S0002-9343(07)00166-0 [pii]10.1016/j.amjmed.2006.08.036 (2007).
- 259 Lleo, A., Greenberg, S. M. & Growdon, J. H. Current pharmacotherapy for Alzheimer's disease. *Annu Rev Med* 57, 513-533, doi:10.1146/annurev.med.57.121304.131442 (2006).
- 260 Schmitt, B., Bernhardt, T., Moeller, H. J., Heuser, I. & Frolich, L. Combination therapy in Alzheimer's disease: a review of current evidence. *CNS Drugs* 18, 827-844, doi:18131 [pii] (2004).
- 261 Caccamo, A., Oddo, S., Tran, L. X. & LaFerla, F. M. Lithium reduces tau phosphorylation but not A beta or working memory deficits in a transgenic model with both plaques and tangles. *Am J Pathol* 170, 1669-1675, doi:170/5/1669 [pii]10.2353/ajpath.2007.061178 (2007).
- 262 Morris, R. Developments of a water-maze procedure for studying spatial learning in the rat. *J Neurosci Methods* 11, 47-60, doi:0165-0270(84)90007-4 [pii] (1984).
- 263 Cedazo-Minguez, A., Wiehager, B., Winblad, B., Huttinger, M. & Cowburn, R. F. Effects of apolipoprotein E (apoE) isoforms, beta-amyloid (Abeta) and apoE/Abeta complexes on protein kinase C-alpha (PKC-alpha) translocation and amyloid precursor protein (APP) processing in human SH-SY5Y neuroblastoma cells and fibroblasts. *Neurochem Int* 38, 615-625, doi:S0197018600001285 [pii] (2001).
- 264 Nakazawa, K., McHugh, T. J., Wilson, M. A. & Tonegawa, S. NMDA receptors, place cells and hippocampal spatial memory. *Nat Rev Neurosci* 5, 361-372, doi:10.1038/nrn1385 [pii] (2004).
- 265 Grootendorst, J. *et al.* Human apoE targeted replacement mouse lines: h-apoE4 and h-apoE3 mice differ on spatial memory performance and avoidance behavior. *Behav Brain Res* 159, 1-14, doi:S0166-4328(04)00378-X [pii]10.1016/j.bbr.2004.09.019 (2005).
- 266 Raber, J. *et al.* Apolipoprotein E and cognitive performance. *Nature* 404, 352-354, doi:10.1038/35006165 (2000).

- 267 Rosenzweig, E. S. & Barnes, C. A. Impact of aging on hippocampal function: plasticity, network dynamics, and cognition. *Prog Neurobiol* 69, 143-179, doi:S0301008202001260 [pii] (2003).

